

# Dagger Series

D38999 Size 19-18 Optical Quad Transmitter, \*ELIO®, 850nm, ARINC 818, 803 & 804

Quad TX, Flange Mount

## FEATURES

- Compliant with ARINC 818, 803 & 804
- Suitable for 1x/2x/4xFibre Channel and sFPDP applications from 50Mbps to 4.25Gbps
- Maximum optical channel bit error rate less than  $1 \times 10^{-12}$
- Operating temperature range from -55°C to +85°C
- Shock and vibration resistant per RTCA / D0-160E
- Electroless nickel plating meets stringent corrosion resistance specifications
- ELIO® 2.5mm ceramic optical fiber ferrule connector interface per EN 4531, ABS 1379 and ARINC 801
- Compatible with D38999/19-04 ELIO® connectors

## APPLICATIONS

Dagger series D38999/19-18 optical transmitters enable high speed network communications over long distances in harsh environments.

- Fibre Channel switches and peripherals
- ARINC 818 video interfaces
- sFPDP data links

Dagger series D38999 size 19-18 optical quad transmitters provide a rugged optical interface that is compliant with EN4531 ELIO® 2.5mm ceramic optical ferrules\*.

The multimode optical fiber interface supports applications where copper cable link distance, bandwidth, weight or bulk make the use of twisted pair, twinax or quadax copper conductors unacceptable.

\*ELIO® is a registered trademark of Esterline Souriau



Four optical TX Links operating from 50Mbps to 4.25Gbps

## DESCRIPTION

Dagger series D38999/19-18 optical quad transmitters consist of optoelectronic transmitter functions integrated into a wall mount D38999 cylindrical connector.

The optical transmitters are 850nm VCSEL lasers. The transmitter input lines are driven with differential CML signals applied to the transmitter (TX+ and TX-) lines. Dual loop, temperature compensated, VCSEL drivers convert the transmitter input signals to suitable VCSEL bias and modulation currents.

The optical mating interface of the Dagger series D38999/19-04 optical transmitters is an ELIO® fiber optic cable plug per EN 4531. The electrical interface to the Dagger series optical transmitters is a ribbon coax to Samtec EQCD high density cable assembly enabling SMT interconnection to a customer's backplane, motherboard or daughtercard.

Dagger series D38999/19-18 optical transmitters are vibration isolated, environmentally hardened components designed for use in harsh environment applications.

## ORDERING INFORMATION

Application	Part Number
50Mbps to 3.19Gbps	P12F-4T1E-Fx-Lxxx
3.2Gbps to 4.25Gbps	P12F-4T1G-Fx-Lxxx

See Appendix A2 for more part number options

Dagger Series D38999/19-18 ELIO Optical Quad Transmitter,  
Multimode, 850nm, ARINC 664, 818, 803 & 804 Compliant

### ABSOLUTE MAXIMUM RATINGS

Absolute maximum limits mean that no catastrophic damage will occur if the product is subjected to these ratings for short periods, provided each limiting parameter is in isolation and all other parameters have values within the performance specification. It should not be assumed that limiting values of more than one parameter can be applied to the product at the same time.

Parameter	Symbol	Minimum	Typical	Maximum	Unit
Storage Temperature	$T_s$	-65		+100	°C
Supply Voltage	$V_{CC}$	-0.5		+4.5	V

### RECOMMENDED OPERATING CONDITIONS

Parameter	Symbol	Minimum	Typical	Maximum	Unit
Operating Temperature	$T_A$	-55		+85	°C
Power Supply Voltage	$V_{CC}$	+3.135		+3.465	V
Power Supply Noise (p-p)	$N_p$			200	mV

### SPECIFICATIONS COMPLIANCE

Requirement	Feature	Condition	Notes
RTCA / D0-160E	ESD	Class II	2200V
RTCA / D0-160E	Vibration	3.8g <sup>2</sup> /Hz	43G rms
RTCA / D0-160E	Shock	40.0g	6-9mS
RTCA / D0-160E	Flame Resistance	Method 1012	30 Seconds
RTCA / D0-160E	Damp Heat	10 Cycles	24 Hours
EN4531	Mating Durability	500 Cycles	<0.5dB Change
FDA / CDRH / IEC-825-1	Eye Safety	Class 1	No Safety Interlocks Required

### MATERIALS

Item	Detail	Notes
D38999 Shell	Aluminum	
D38999 Shell Finish	NI, OD-CD or ZN-NI	
Interface Seal	Silicone Elastomer	
Optical Ferrules and Alignment Sleeves	Ceramic	
Printed Circuits	FR-4	

Dagger Series D38999/19-18 ELIO Optical Quad Transmitter,  
Multimode, 850nm, ARINC 664, 818, 803 & 804 Compliant

**OPTICAL TRANSMITTERS**  $T_A$  = Operating Temperature Range,  $V_{CC}$  = 3.135V to 3.465V

Parameter	Symbol	Minimum	Typical	Maximum	Unit
Optical Output Power (BER<10 <sup>-12</sup> )	$P_o$	-6.5		-1.0	dBm
Optical Output Wavelength	$\lambda_{OUT}$	830	850	860	nM
Spectral Width	$\Delta\lambda_{RMS}$			0.85	nM
Extinction Ratio					
xxxx-xx1E-xx @ 125Mbps to 1.25Gbps	ER	9.0			dB
xxxx-xx1E-xx @ 2.125Gbps		9.0			
xxxx-xx1E-xx @ 2.5Gbps to 3.19Gbps		6.0			
xxxx-xx1G-xx @ 3.2Gbps to 4.25Gbps		6.0			

**POWER SUPPLY CURRENT**  $T_A$  = Operating Temperature Range,  $V_{CC}$  = 3.135V to 3.465V

Parameter	Symbol	Minimum	Typical	Maximum	Unit
Supply Current per transmitter	$I_{CCT}$		80	110	mA

Dagger Series D38999/19-18 ELIO Optical Quad Transmitter,  
Multimode, 850nm, ARINC 664, 818, 803 & 804 Compliant

**OUTLINE DRAWING**

Dimensions are shown as: inches [mm]

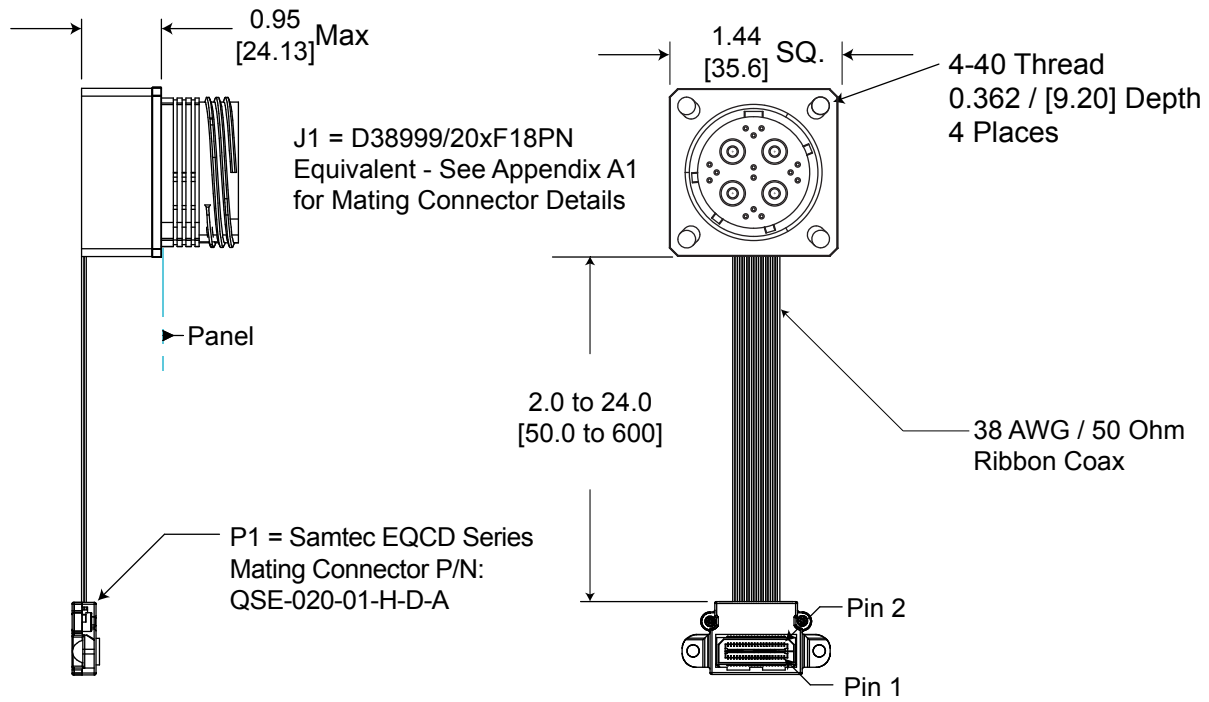

**Panel Cutout Dimensions**  
Rear Panel Mounting Only

Shell Size Code	Shell Size	M Min	P Holes	R BSC
F	19	1.297 (32.94)	0.133 (3.4) 0.123 (3.1)	1.156 (29.4)

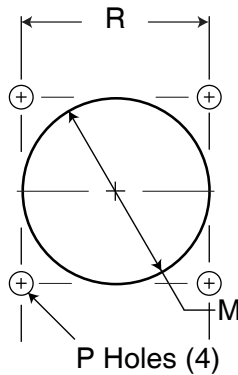

Dagger Series D38999/19-18 ELIO Optical Quad Transmitter,  
Multimode, 850nm, ARINC 664, 818, 803 & 804 Compliant

## OUTLINE DRAWING

Cable Length Options

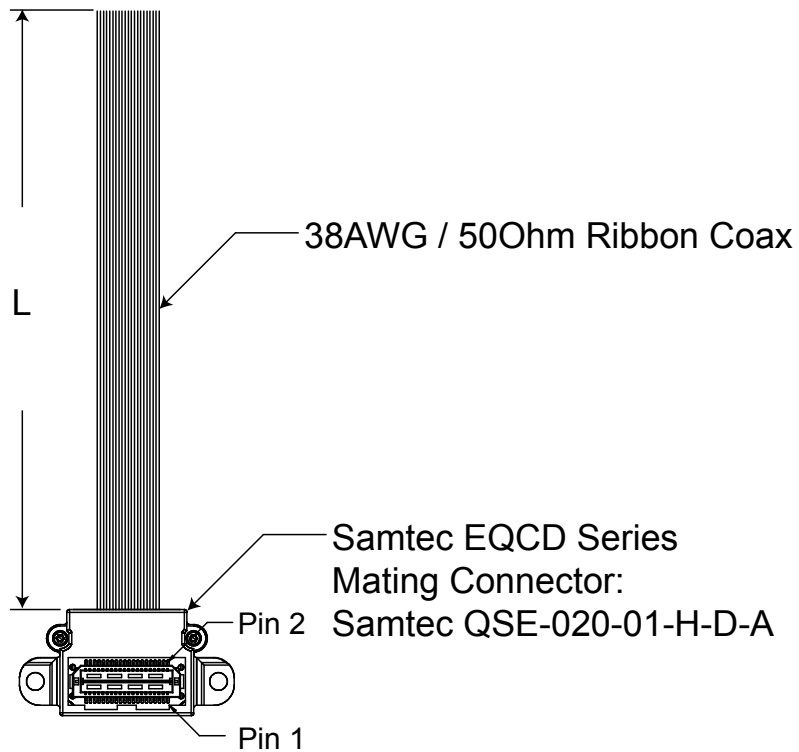

### Ribbon Coax Cable Length Options

L (mm) +/- 6.0	ITEM #
----------------	--------

See Appendix A2 on Page 10

Dagger Series D38999/19-18 ELIO Optical Quad Transmitter,  
 Multimode, 850nm, ARINC 664, 818, 803 & 804 Compliant

## OPTICAL INSERT ARRANGEMENT

### TOP Optical Interface

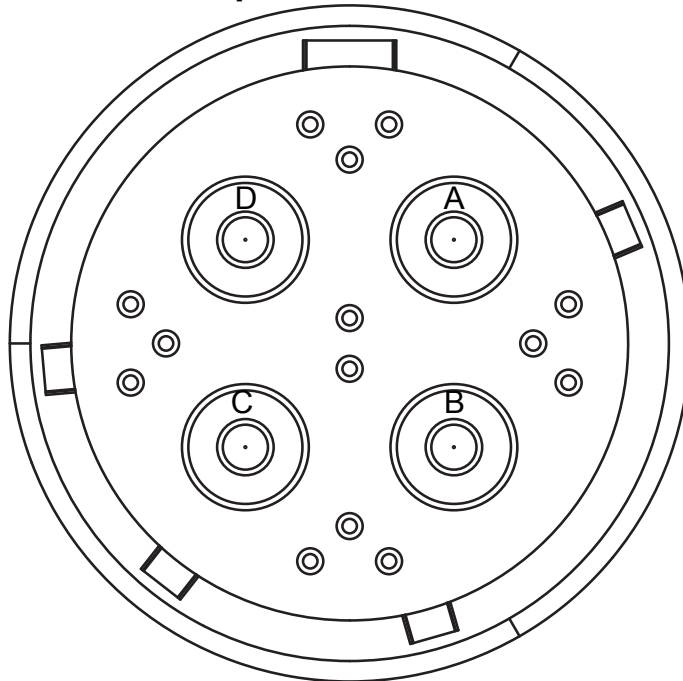

Front face of the optical  
 insert shown, fiber optic cable plug  
 opposite - see Appendix A2  
 for details

## OPTICAL PORT ASSIGNMENTS

Dagger Series D38999/19-18 Optical Interface

D38999 CAVITY CODE	LOGICAL PORT NUMBER	PORT FUNCTION
A	0	RX
B	0	TX
C	1	RX
D	1	TX

Dagger Series D38999/19-18 ELIO Optical Quad Transmitter,  
Multimode, 850nm, ARINC 664, 818, 803 & 804 Compliant

**PRINTED CIRCUIT BOARD FOOTPRINT**

All dimensions shown are for reference only: inches [mm]

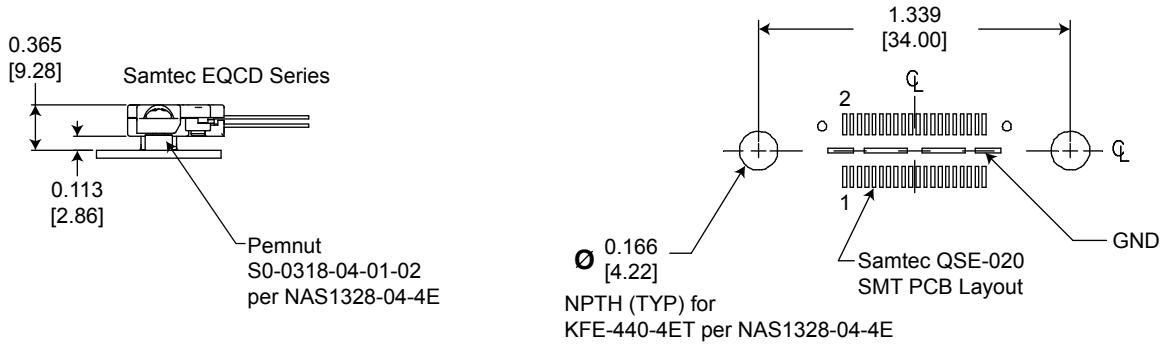

**SAMTEC EQCD PIN ASSIGNMENTS**

ELECTRICAL			PORT #	OPTICAL	
PIN #	FUNCTION	LOGIC FAMILY		PIN #	FUNCTION
1	TX_DIS	CMOS	0	0	TX
2	GND	N/A	0-3	0-3	
3	TX-	CML	0	0	
4	NC	N/A	N/A	N/A	
5	TX+	CML	0	0	
6	TX_DIS	CMOS	1	1	
7	TX-	CML	1	1	
8	V <sub>CC</sub>	3.135 to 3.465VDC	0-3	0-3	
9	TX+	CML	1	1	
10	V <sub>CC</sub>	3.135 to 3.465VDC	0-3	0-3	
11	TX_DIS	CMOS	2	2	
12	GND	N/A	0-3	0-3	
13	TX-	CML	2	2	
14	NC	N/A	N/A	N/A	
15	TX+	CML	2	0	
16	TX_DIS	CMOS	3	3	
17	TX-	CML	3	3	
18	V <sub>CC</sub>	3.135 to 3.465VDC	0-3	0-3	
19	TX+	CML	3	3	
20	V <sub>CC</sub>	3.135 to 3.465VDC	0-3	0-3	

Center slug is Ground.

For the Transmit Disable (TX\_DIS) Functions: Logic 1: Disable Optical Output, Logic 0: Enable Optical Output

All CML functions are internally AC coupled with 100Ω differential termination.

All other pins are NC.

## APPLICATION SCHEMATIC

For Xilinx Rocket I/O Interfaces

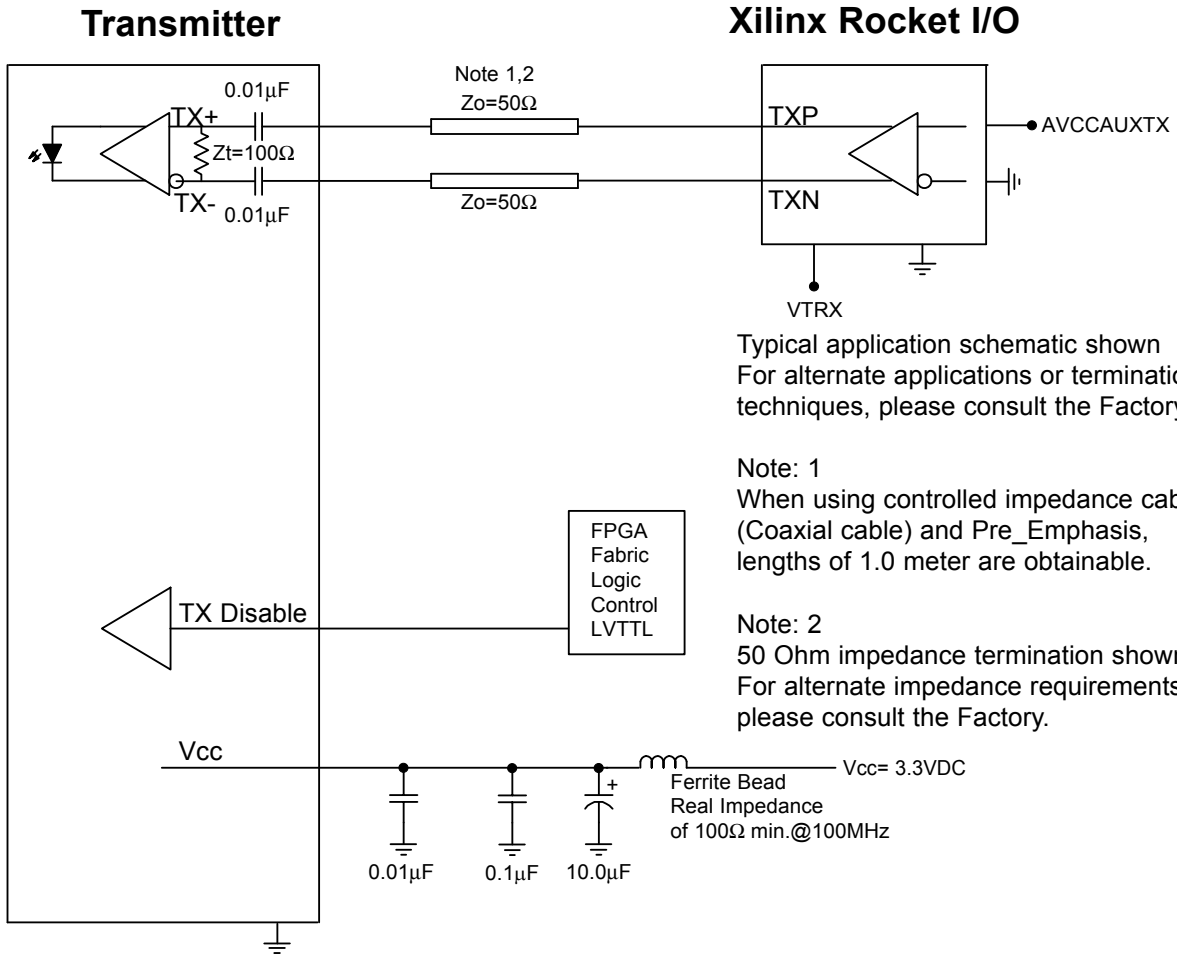



Dagger Series D38999/19-18 ELIO Optical Quad Transmitter,  
Multimode, 850nm, ARINC 664, 818, 803 & 804 Compliant

## APPENDIX A1

### Mating Fiber Optic Cable - Plug Configuration

#### FIBER OPTIC CABLE PLUG - SOCKET INSERT

ESTERLINE SOURIAU PART NUMBER = 8D5Q19x84SN621L    x = Finish Code

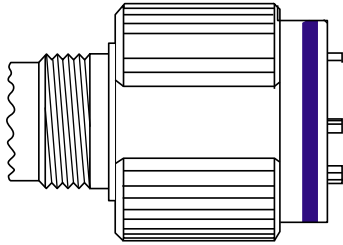

#### SIZE 8 CAVITY ADAPTOR FOR ELIO TERMINI

ESTERLINE SOURIAU PART NUMBER = ELIOAQ6SB



#### ESTERLINE SOURIAU ELIO TERMINI

##### ELIO<sup>®</sup> multimode contact Ordering information

ELIO	09N	G	L	A
Cable external diameter & Contact sealing:				
09N: 0.9 <sup>mm</sup> , Non waterproof				
18N: from 1.5mm to 1.9mm, Non waterproof				
18W: 1.8 <sup>mm</sup> , Waterproof				
20N: from 1.7mm to 2.1mm, Non waterproof				
20W: 2.0 <sup>mm</sup> , Waterproof				
Fibre type:				
G: ELIO <sup>®</sup> Multimode				
Boot type:				
L: Long boot				
S: Short boot				
N: No boot (non waterproof version only)				
Contact version index				



## APPENDIX A2

### PART NUMBER OPTIONS

Dagger D38999/19-18 Series

**P12 X - 4 X 1 X - F X X - L**

Shell Configuration  
P12= D38999 / ELIO

Shell Configuration  
F= Square Flange  
J= Jam Nut

Fiber Ports  
4= 4x Optical Ports

Configuration  
R = 4xRX  
S = 2xTX + 2xRX  
T = 4xTX

Cable Mode  
1= Multimode

Datarate  
E = 0.1 to 3.19Gbps  
G = 3.2 to 4.25Gbps

Shell Size Code  
F = D38999/19-18

Shell Plating  
F = NI  
W = OD CD  
Z = ZN / NI

Polarization  
(leave blank) \_ = N  
A = A  
B = B  
C = C  
D = D

Electrical Interface  
L = Ribbon Coax to  
Samtec EQCD Series -  
Cable Length TBD



192 Bob Fitz Road, Johnson City, TN 37615  
salesmp@moog.com  
moogprotokraft.com