

Dagger Series

D38999 Size 25-08 Quad Port Optical Transceiver, *ELIO®, 850nm, ARINC 818, 803 & 804

Quad Port, Flange Mount

FEATURES

- Compliant with ARINC 818, 803 & 804
- Suitable for Fast Ethernet, Gigabit Ethernet, 1x/2x/4xFibre Channel and sFPDP applications from 50Mbps to 4.25Gbps
- Maximum optical channel bit error rate less than 1×10^{-12}
- Operating temperature range from -55°C to +85°C
- Shock and vibration resistant per RTCA / D0-160E
- Electroless nickel plating meets stringent corrosion resistance specifications
- ELIO® 2.5mm ceramic optical fiber ferrule connector interface per EN 4531 and ABS 1379
- Compatible with D38999/25-08 ELIO® connectors

APPLICATIONS

Dagger series D38999/25-08 optical transceivers enable high speed network communications over long distances in harsh environments.

- Fast or Gigabit Ethernet switches and peripherals
- Fibre Channel switches and peripherals
- ARINC 818 video interfaces
- sFPDP data links

Dagger series D38999 size 25-08 optical transceivers provide a rugged optical interface that is compliant with EN4531 ELIO® 2.5mm ceramic optical ferrules*.

The multimode optical fiber interface supports applications where copper cable link distance, bandwidth, weight or bulk make the use of twisted pair, twinax or quadrx copper conductors unacceptable.

*ELIO® is a registered trademark of Esterline Souriau



Four duplex optical links operating from 50Mbps to 4.25Gbps

DESCRIPTION

Dagger series D38999/25-08 optical transceivers consist of optoelectronic transmitter and receiver functions integrated into a wall mount D38999 cylindrical connector.

The optical transmitters are 850nm VCSEL lasers. The transmitter input lines are driven with differential CML signals applied to the transmitter (TX+ and TX-) lines. Dual loop, temperature compensated, VCSEL drivers convert the transmitter input signals to suitable VCSEL bias and modulation currents.

The optical receivers consist of PIN and preamplifier assemblies and limiting post-amplifiers. Outputs from the receivers consist of differential CML data signals on the receiver (RX+ and RX-) lines and single ended CMOS indicator functions on the Loss of Signal (LOS) lines. The receiver data lines are squelched upon LOS assertion, preventing errant data generation when an invalid incoming optical signal is presented to the transceiver.

The optical mating interface of the Dagger series D38999/25-08 optical transceivers is an ELIO® fiber optic cable plug per EN 4531. The electrical interface to the Dagger series optical transceivers is a ribbon coax to Samtec EQCD high density cable assembly enabling SMT interconnection to a customer's backplane, motherboard or daughtercard.

Dagger series D38999/25-08 optical transceivers are vibration isolated, environmentally hardened components designed for use in harsh environment applications.

ORDERING INFORMATION

Application	Part Number
50Mbps to 3.19Gbps	P12F-8S1E-Jx-Lxxx
3.2Gbps to 4.25Gbps	P12F-8S1G-Jx-Lxxx

See Page 11 for more part number options

Dagger Series D38999/25-08 ELIO Quad Port Optical Transceiver,
Multimode, 850nm, ARINC 664, 818, 803 & 804 Compliant

ABSOLUTE MAXIMUM RATINGS

Absolute maximum limits mean that no catastrophic damage will occur if the product is subjected to these ratings for short periods, provided each limiting parameter is in isolation and all other parameters have values within the performance specification. It should not be assumed that limiting values of more than one parameter can be applied to the product at the same time.

Parameter	Symbol	Minimum	Typical	Maximum	Unit
Storage Temperature	T_s	-65		+100	°C
Supply Voltage	V_{CC}	-0.5		+4.5	V

RECOMMENDED OPERATING CONDITIONS

Parameter	Symbol	Minimum	Typical	Maximum	Unit
Operating Temperature	T_A	-55		+85	°C
Power Supply Voltage	V_{CC}	+3.135		+3.465	V
Power Supply Noise (p-p)	N_p			200	mV

SPECIFICATIONS COMPLIANCE

Requirement	Feature	Condition	Notes
RTCA / D0-160E	ESD	Class II	2200V
RTCA / D0-160E	Vibration	3.8g ² /Hz	43G rms
RTCA / D0-160E	Shock	40.0g	6-9mS
RTCA / D0-160E	Flame Resistance	Method 1012	30 Seconds
RTCA / D0-160E	Damp Heat	10 Cycles	24 Hours
EN4531	Mating Durability	500 Cycles	<0.5dB Change
FDA / CDRH / IEC-825-1	Eye Safety	Class 1	No Safety Interlocks Required

MATERIALS

Item	Detail	Notes
D38999 Shell	Aluminum	
D38999 Shell Finish	NI, OD-CD or ZN-NI	
Interface Seal	Silicone Elastomer	
Optical Ferrules and Alignment Sleeves	Ceramic	
Printed Circuits	FR-4	

Dagger Series D38999/25-08 ELIO Quad Port Optical Transceiver,
Multimode, 850nm, ARINC 664, 818, 803 & 804 Compliant

OPTICAL TRANSMITTERS T_A = Operating Temperature Range, V_{CC} = 3.135V to 3.465V

Parameter	Symbol	Minimum	Typical	Maximum	Unit
Optical Output Power (BER<10 ⁻¹²)	P_o	-6.5		-1.0	dBm
Optical Output Wavelength	λ_{OUT}	830	850	860	nM
Spectral Width	$\Delta\lambda_{RMS}$			0.85	nM
Extinction Ratio xxxx-xx1E-xx @ 125Mbps to 1.25Gbps xxxx-xx1E-xx @ 2.125Gbps xxxx-xx1E-xx @ 2.5Gbps to 3.19Gbps xxxx-xx1G-xx @ 3.2Gbps to 4.25Gbps	ER	9.0 9.0 6.0 6.0			dB

OPTICAL RECEIVERS T_A = Operating Temperature Range, V_{CC} = 3.135V to 3.465V

Parameter	Symbol	Minimum	Typical	Maximum	Unit
Optical Sensitivity (BER<10 ⁻¹² , ER=9.0) xxxx-xx1E-xx @ 50Mbps to 1.25Gbps xxxx-xx1E-xx @ 2.125Gbps xxxx-xx1E-xx @ 2.5Gbps to 3.19Gbps xxxx-xx1G-xx @ 3.2Gbps to 4.25Gbps	P_i	-17.0 -15.0 -15.0 -14.0		0.0	dBm
Optical Wavelength	λ_{IN}	830		860	nM
Optical Modulation Amplitude (ER=9.0, p-p) xxxx-xx1E-xx @ 50Mbps to 1.25Gbps xxxx-xx1E-xx @ 2.125Gbps xxxx-xx1E-xx @ 2.5Gbps to 3.19Gbps xxxx-xx1G-xx @ 3.2Gbps to 4.25Gbps	OMA	31 49 56 61			μ W
CML Differential Output Voltage (p-p)	V_{Diff}	600	780	1200	mV
Loss of Signal (LOS) Deassert Level	P_{OFFr}	-28.0			dBm
Loss of Signal (LOS) Hysteresis	HYS	1.5	2.25	3.5	dB

POWER SUPPLY CURRENT T_A = Operating Temperature Range, V_{CC} = 3.135V to 3.465V

Parameter	Symbol	Minimum	Typical	Maximum	Unit
Supply Current per transmitter or receiver	I_{CCT}		80	110	mA

Dagger Series D38999/25-08 ELIO Quad Port Optical Transceiver,
Multimode, 850nm, ARINC 664, 818, 803 & 804 Compliant

OUTLINE DRAWING

Dimensions are shown as: inches [mm]

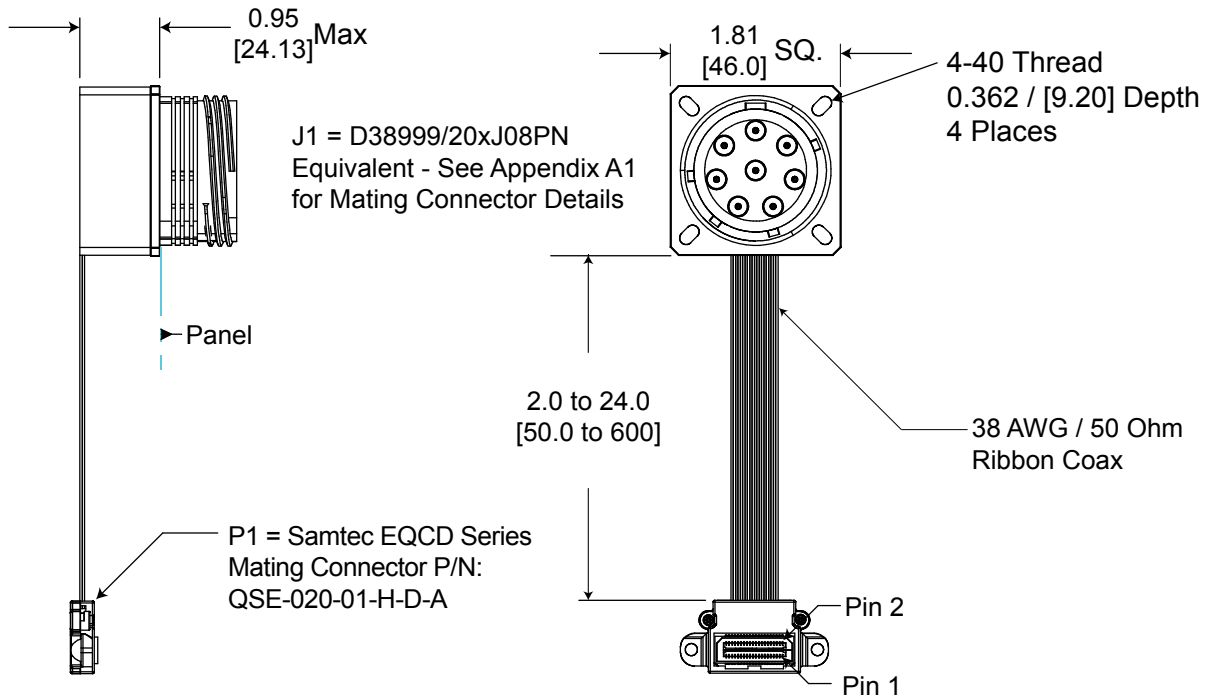

Panel Cutout Dimensions
Rear Panel Mounting Only

Shell Size Code	Shell Size	M Min	P Holes	R BSC
J	25	1.660 (42.47)	0.133 (3.4) 0.123 (3.1)	1.500 (38.10)

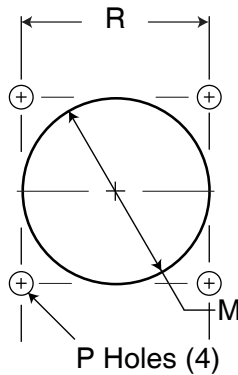

Dagger Series D38999/25-08 ELIO Quad Port Optical Transceiver,
Multimode, 850nm, ARINC 664, 818, 803 & 804 Compliant

OUTLINE DRAWING

Cable Length Options

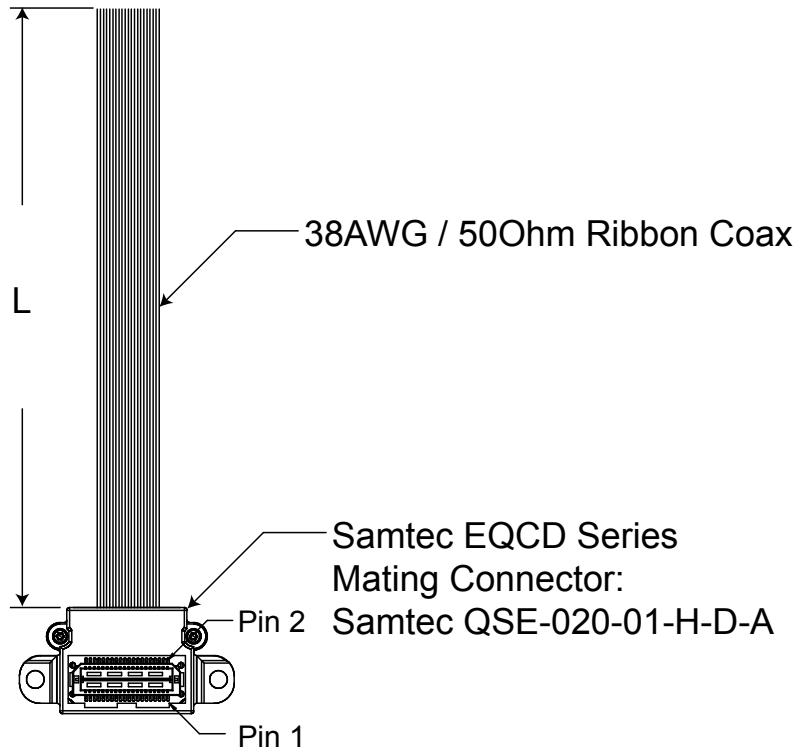

Ribbon Coax Cable Length Options

L (mm) +/- 6.0	ITEM #
----------------	--------

See Appendix A2 on Page 10

Dagger Series D38999/25-08 ELIO Quad Port Optical Transceiver,
 Multimode, 850nm, ARINC 664, 818, 803 & 804 Compliant

OPTICAL INSERT ARRANGEMENT

**TOP
 Optical Interface**

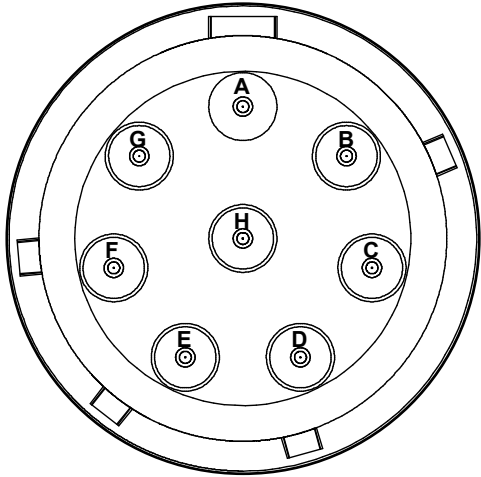

Front face of the optical insert shown, fiber optic cable plug opposite - see Appendix A2 for details

OPTICAL PORT ASSIGNMENTS

Dagger Series D38999/25-08 Optical Interface

D38999 CAVITY CODE	LOGICAL PORT NUMBER	PORT FUNCTION
A	1	TX
B	0	TX
C	0	RX
D	1	RX
E	2	TX
F	3	TX
G	3	RX
H	2	RX

Dagger Series D38999/25-08 ELIO Quad Port Optical Transceiver,
Multimode, 850nm, ARINC 664, 818, 803 & 804 Compliant

PRINTED CIRCUIT BOARD FOOTPRINT

All dimensions shown are for reference only: inches [mm]

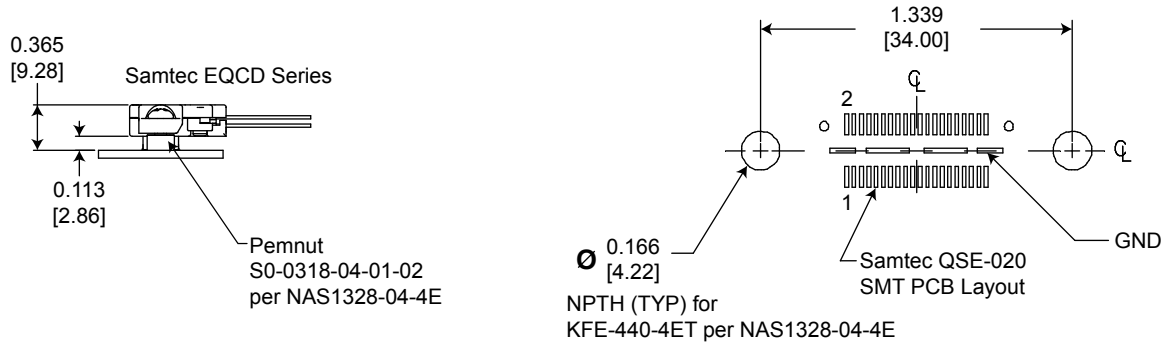

SAMTEC EQCD PIN ASSIGNMENTS - Continued on the next page

ELECTRICAL			PORT #	OPTICAL PIN #
PIN #	FUNCTION	LOGIC FAMILY		
1	LOS	Open Drain CMOS	0	C
2	GND	N/A	ALL	ALL
3	RX-	CML	0	C
4	NC	N/A	N/A	N/A
5	RX+	CML	0	C
6	TX_DIS	CMOS	0	B
7	TX-	CML	0	B
8	V _{cc}	3.135 to 3.465VDC	ALL	ALL
9	TX+	CML	0	B
10	V _{cc}	3.135 to 3.465VDC	ALL	ALL
11	LOS	Open Drain CMOS	1	D
12	GND	N/A	ALL	ALL
13	RX-	CML	1	D
14	NC	N/A	N/A	N/A
15	RX+	CML	1	D
16	TX_DIS	CMOS	1	A
17	TX-	CML	1	A
18	V _{cc}	3.135 to 3.465VDC	ALL	ALL
19	TX+	CML	1	A
20	V _{cc}	3.135 to 3.465VDC	ALL	ALL

Center slug is Ground.

For the Transmit Disable (TX_DIS) Functions: Logic 1: Disable Optical Output, Logic 0: Enable Optical Output

For the Loss of Signal (LOS) Functions: Satisfactory Optical Input: Logic "0" Output, Unsatisfactory Optical Input: Logic "1" Output

All CML functions are internally AC coupled with 100Ω differential termination.

All other pins are NC.

Dagger Series D38999/25-08 ELIO Quad Port Optical Transceiver,
Multimode, 850nm, ARINC 664, 818, 803 & 804 Compliant

PRINTED CIRCUIT BOARD FOOTPRINT

All dimensions shown are for reference only: inches [mm]

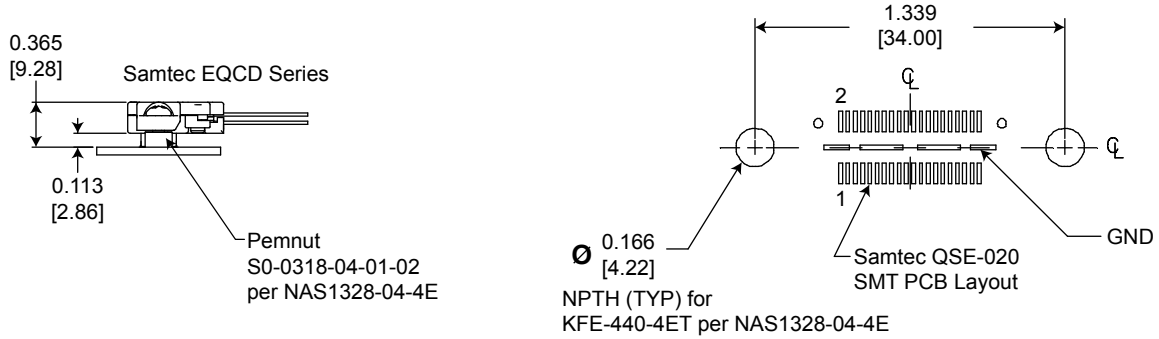

SAMTEC EQCD PIN ASSIGNMENTS - Continued from the previous page

ELECTRICAL			PORT #	OPTICAL PIN #
PIN #	FUNCTION	LOGIC FAMILY		
21	LOS	Open Drain CMOS	2	H
22	GND	N/A	ALL	ALL
23	RX-	CML	2	H
24	NC	N/A	N/A	N/A
25	RX+	CML	2	H
26	TX_DIS	CMOS	2	E
27	TX-	CML	2	E
28	V _{cc}	3.135 to 3.465VDC	ALL	ALL
29	TX+	CML	2	E
30	V _{cc}	3.135 to 3.465VDC	ALL	ALL
31	LOS	Open Drain CMOS	3	G
32	GND	N/A	ALL	ALL
33	RX-	CML	3	G
34	NC	N/A	N/A	N/A
35	RX+	CML	3	G
36	TX_DIS	CMOS	3	F
37	TX-	CML	3	F
38	V _{cc}	3.135 to 3.465VDC	ALL	ALL
39	TX+	CML	3	F
40	V _{cc}	3.135 to 3.465VDC	ALL	ALL

Center slug is Ground.

For the Transmit Disable (TX_DIS) Functions: Logic 1: Disable Optical Output, Logic 0: Enable Optical Output

For the Loss of Signal (LOS) Functions: Satisfactory Optical Input: Logic "0" Output, Unsatisfactory Optical Input: Logic "1" Output

All CML functions are internally AC coupled with 100Ω differential termination.

All other pins are NC

Dagger Series D38999/25-08 ELIO Quad Port Optical Transceiver,
Multimode, 850nm, ARINC 664, 818, 803 & 804 Compliant

APPLICATION SCHEMATIC
For Xilinx Rocket I/O Interfaces

Optical Transceiver

Xilinx Rocket I/O

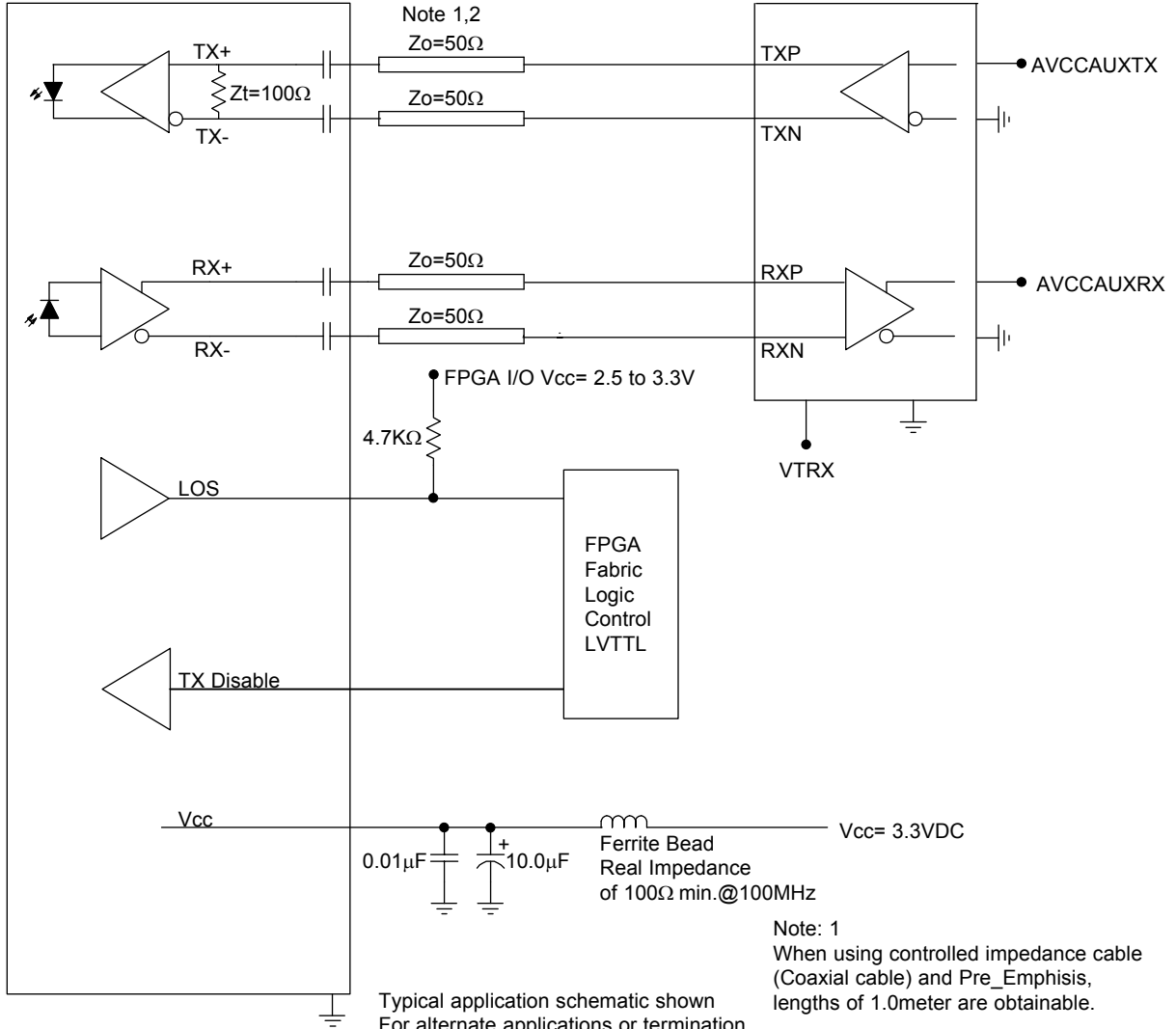

Typical application schematic shown
For alternate applications or termination
techniques, please consult the Factory

Note: 1
When using controlled impedance cable
(Coaxial cable) and Pre_Emphasis,
lengths of 1.0meter are obtainable.

Note: 2
50 Ohm impedance termination shown.
For alternate impedance requirements,
please consult the Factory.

Dagger Series D38999/25-08 ELIO Quad Port Optical Transceiver,
Multimode, 850nm, ARINC 664, 818, 803 & 804 Compliant

APPENDIX A1

Mating Fiber Optic Cable - Plug Configuration

FIBER OPTIC CABLE PLUG - SOCKET INSERT

ESTERLINE SOURIAU PART NUMBER = 8D5Q25X88SN621L X = Finish Code

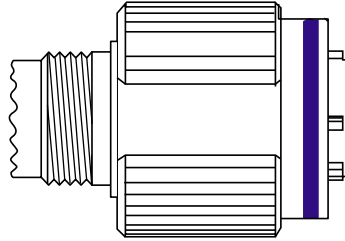

SIZE 8 CAVITY ADAPTOR FOR ELIO TERMINI

ESTERLINE SOURIAU PART NUMBER = ELIOAQ6SB



ESTERLINE SOURIAU ELIO TERMINI

ELIO® multimode contact
Ordering information

ELIO	09N	G	L	A
Cable external diameter & Contact sealing:				
09N: 0.9 ^{+0.1} mm. Non waterproof				
18N: from 1.5mm to 1.9mm. Non waterproof				
18W: 1.8 ^{+0.1} mm. Waterproof				
20N: from 1.7mm to 2.1mm. Non waterproof				
20W: 2.0 ^{+0.1} mm. Waterproof				
Fibre type:				
G: ELIO® Multimode				
Boot type:				
L: Long boot				
S: Short boot				
N: No boot (non waterproof version only)				
Contact version index				



APPENDIX A2

PART NUMBER OPTIONS

Dagger D38999/25-08 Series

P12 **X** - **8** **X** **1** **X** - **J** **X** **X** - **L**

Shell Configuration
P12= D38999 / ELIO

Shell Configuration
F= Square Flange
J= Jam Nut

Fiber Ports
8= 8x Optical Ports

Configuration
R = 8xRX
S = 4xTX +4xRX
T = 8xTX

Cable Mode
1= Multimode

Datarate
E = 0.1 to 3.19Gbps
G = 3.2 to 4.25Gbps

Shell Size Code
J = D38999/25-08

Shell Plating
F = NI
W = OD CD
Z= ZN / NI

Polarization
(leave blank) _ = N
A = A
B = B
C = C
D = D

Electrical Interface
L = Ribbon Coax to
Samtec EQCD Series -
Cable Length TBD



192 Bob Fitz Road, Johnson City, TN 37615
salesmp@moog.com
moogprotokraft.com