

DAGGER SERIES

D38999 SIZE 19-18 DUAL PORT OPTICAL TRANSCEIVER, 850nm, ARINC 818, 801, 803 & 804

Two duplex optical links operating up to 5Gbps



Dagger series D38999/19-18 optical quad transmitters consist of optoelectronic transmitter and receiver functions integrated into a wall mount D38999 cylindrical connector.

The optical transmitters are 850nm VCSEL lasers. The transmitter input lines are driven with differential CML signals applied to the transmitter (TX+ and TX-) lines. Dual loop, temperature compensated, VCSEL drivers convert the transmitter input signals to suitable VCSEL bias and modulation currents.

The optical receivers consist of PIN and preamplifier assemblies and limiting post-amplifiers. Outputs from the receivers consist of differential CML data signals on the receiver (RX+ and RX-) lines and single ended CMOS indicator functions on the Loss of Signal (LOS) lines. The receiver data lines are squelched upon LOS assertion, preventing errant data generation when an invalid incoming optical signal is presented to the transceiver.

The optical mating interface of the Dagger series D38999/19-18 optical transceiver is an ARINC801 compliant interface. The electrical interface to the Dagger series optical transceivers is a ribbon coax to Samtec EQCD high density cable assembly enabling SMT interconnection to a customer's backplane, motherboard or daughtercard.

Dagger series D38999/19-18 optical transceivers are vibration isolated, environmentally hardened components designed for use in harsh environment applications.

D38999 SIZE 19-18 DUAL PORT OPTICAL TRANSCEIVER, 850nm, ARINC 818, 801, 803 & 804

Dual Port, Flange Mount

FEATURES

- Compliant with ARINC 818, 803 & 804
- Suitable for Gigabit Ethernet, 1x/2x/4xFibre Channel and sFPDP applications from 1.25Gbps to 5.0Gbps
- Maximum optical channel bit error rate less than 1×10^{-12}
- Operating temperature range from -40°C to +85°C
- Shock and vibration resistant per RTCA / D0-160E
- Electroless nickel plating meets stringent corrosion resistance specifications, along with other plating options
- 1.25mm ceramic optical fiber ferrule connector interface per ARINC 801

APPLICATIONS

Dagger series D38999/19-18 optical transceivers enable high speed network communications over long distances in harsh environments.

- Gigabit Ethernet switches and peripherals
- Fibre Channel switches and peripherals
- Serial Rapid I/O (sRIO) interfaces
- PCI - Express Links
- sFPDP data links
- Video displays

Dagger series D38999 size 19-18 optical dual transceivers provide a rugged optical interface that is compliant with ARINC801 ceramic optical ferrules.

The multimode optical fiber interface supports applications where copper cable link distance, bandwidth, weight or bulk make the use of twisted pair, twinax or quadax copper conductors unacceptable.

*ELIO® is a registered trademark of Esterline Souriau

ORDERING INFORMATION

Application	Part Number
Up to 5.0Gbps	P13x-4S1K-Fx-Lxxx

See Appendix A2 for more part number options

D38999 SIZE 19-18 DUAL PORT OPTICAL TRANSCEIVER, 850nm, ARINC 818, 801, 803 & 804

ABSOLUTE MAXIMUM RATINGS

Absolute maximum limits mean that no catastrophic damage will occur if the product is subjected to these ratings for short periods, provided each limiting parameter is in isolation and all other parameters have values within the performance specification. It should not be assumed that limiting values of more than one parameter can be applied to the product at the same time.

Parameter	Symbol	Minimum	Typical	Maximum	Unit
Storage Temperature	T_s	-55		+100	°C
Supply Voltage	V_{cc}	-0.5		+4.5	V

RECOMMENDED OPERATING CONDITIONS

Parameter	Symbol	Minimum	Typical	Maximum	Unit
Operating Temperature	T_A	-40		+85	°C
Power Supply Voltage	V_{cc}	+3.135		+3.465	V
Power Supply Noise (p-p)	N_p			200	mV

SPECIFICATIONS COMPLIANCE

Requirement	Feature	Condition	Notes
RTCA / D0-160E	ESD	Class II	2200V
RTCA / D0-160E	Vibration	3.8g2/Hz	43G rms
RTCA / D0-160E	Shock	40.0g	6-9mS
RTCA / D0-160E	Flame Resistance	Method 1012	30 Seconds
RTCA / D0-160E	Damp Heat	10 Cycles	24 Hours
EN4531	Mating Durability	500 Cycles	<0.5dB Change
FDA / CDRH / IEC-825-1	Eye Safety	Class 1	No Safety Interlocks Required

MATERIALS

Item	Detail	Notes
D38999 Shell	Aluminum	
D38999 Shell Finish	OD-CD, NI or ZN-NI	
Interface Seal	Silicone Elastomer	
Optical Ferrules and Alignment Sleeves	Ceramic	
Printed Circuits	FR-4	

D38999 SIZE 19-18 DUAL PORT OPTICAL TRANSCEIVER, 850nm, ARINC 818, 801, 803 & 804

OPTICAL TRANSMITTERS T_A = OPERATING TEMPERATURE RANGE, V_{CC} = 3.135V TO 3.465V

Parameter	Symbol	Minimum	Typical	Maximum	Unit
Optical Output Power(BER<10 ⁻¹²)	P_o	-6.5		-1.0	dBm
Optical Output Wavelength	λ_{OUT}	840	850	860	nm
Extinction Ratio	ER	3.0			dB

OPTICAL RECEIVERS T_A = OPERATING TEMPERATURE RANGE, V_{CC} = 3.135V TO 3.465V

Parameter	Symbol	Minimum	Typical	Maximum	Unit
Optical Sensitivity (BER<10 ⁻¹² ,ER=9.0)	P_i	-14.0		0.0	dBm
Optical Wavelength	λ_{IN}	840	850	860	nm
CML Differential Output Voltage (p-p)	V_{Diff}	600	780	1200	mV
Loss of Signal (LOS) Deassert Level	P_{OFFr}	-28.0			dBm
Loss of Signal (LOS) Hysteresis	HYS	1.5	2.25	3.5	dB

POWER SUPPLY CURRENT T_A = OPERATING TEMPERATURE RANGE, V_{CC} = 3.135V TO 3.465V

Parameter	Symbol	Minimum	Typical	Maximum	Unit
Supply Current per transmitter or receiver	I_{CCT}		85	100	mA

D38999 SIZE 19-18 DUAL PORT OPTICAL TRANSCEIVER, 850nm, ARINC 818, 801, 803 & 804

OUTLINE DRAWING

Dimensions are shown as: inches [mm]

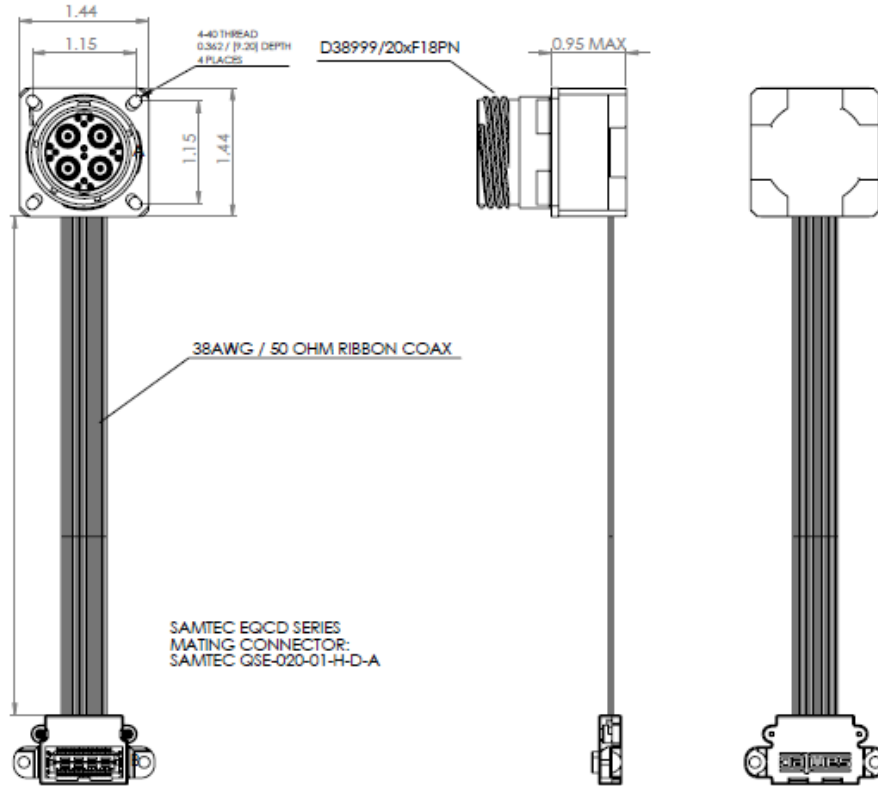

PANEL CUTOUT DIMENSIONS

Rear Panel Mounting Only

Shell Size Code	Shell Size	M Min	P Holes	R BSC
F	19	1.297 (32.94)	0.133 (3.4) 0.123 (3.1)	1.156 (29.4)

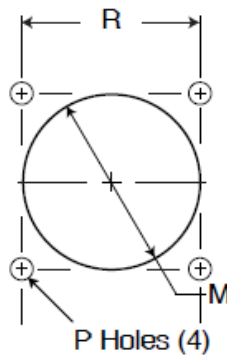

D38999 SIZE 19-18 DUAL PORT OPTICAL TRANSCEIVER, 850nm, ARINC 818, 801, 803 & 804

OUTLINE DRAWING

Cable Length Options

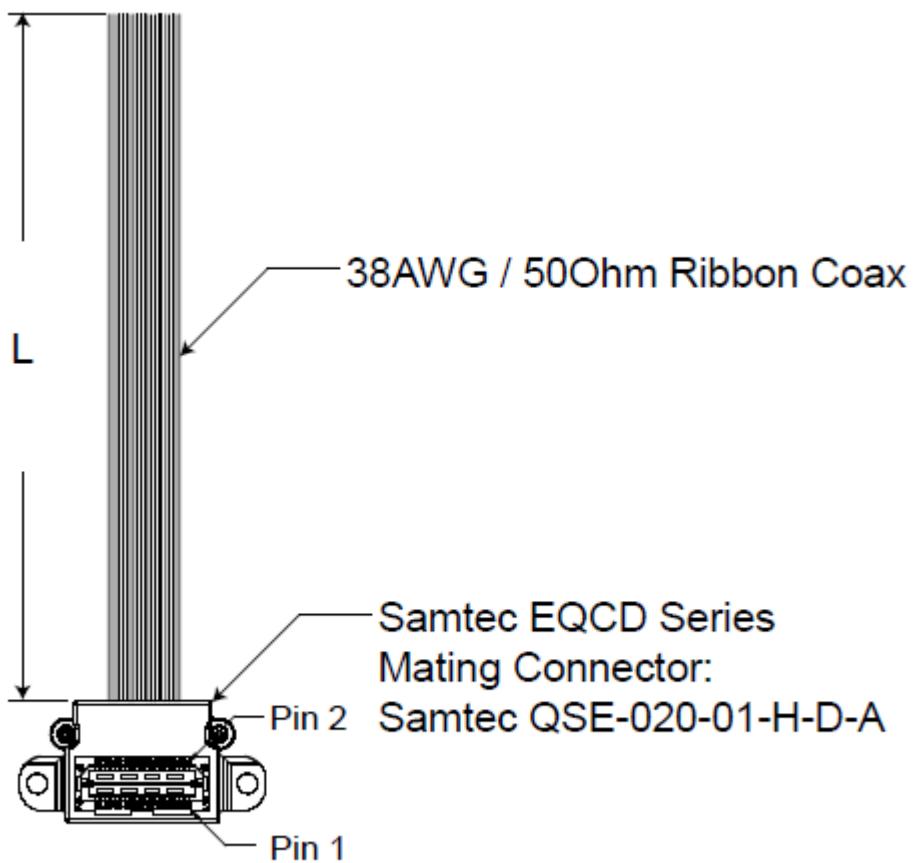

RIBBON COAX CABLE LENGTH OPTIONS

L (mm) +/- 6.0

ITEM #

See available cable length options in Appendix 2

D38999 SIZE 19-18 DUAL PORT OPTICAL TRANSCEIVER, 850nm, ARINC 818, 801, 803 & 804

OPTICAL INSERT ARRANGEMENT

TOP
Optical Interface

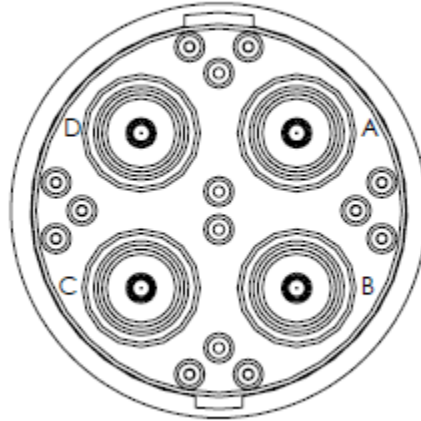

Front face of the optical insert shown,
fiber optic cable plug opposite.
See Appendix A2 for details

OPTICAL PORT ASSIGNMENTS Dagger Series D38999/19-18 Optical Interface

D38999 Cavity Code	Logical Port Number	Port Function
A	0	RX
B	0	TX
C	1	RX
D	1	TX

D38999 SIZE 19-18 DUAL PORT OPTICAL TRANSCEIVER, 850nm, ARINC 818, 801, 803 & 804

PRINTED CIRCUIT BOARD FOOTPRINT

All dimensions shown are for reference only: inches [mm]

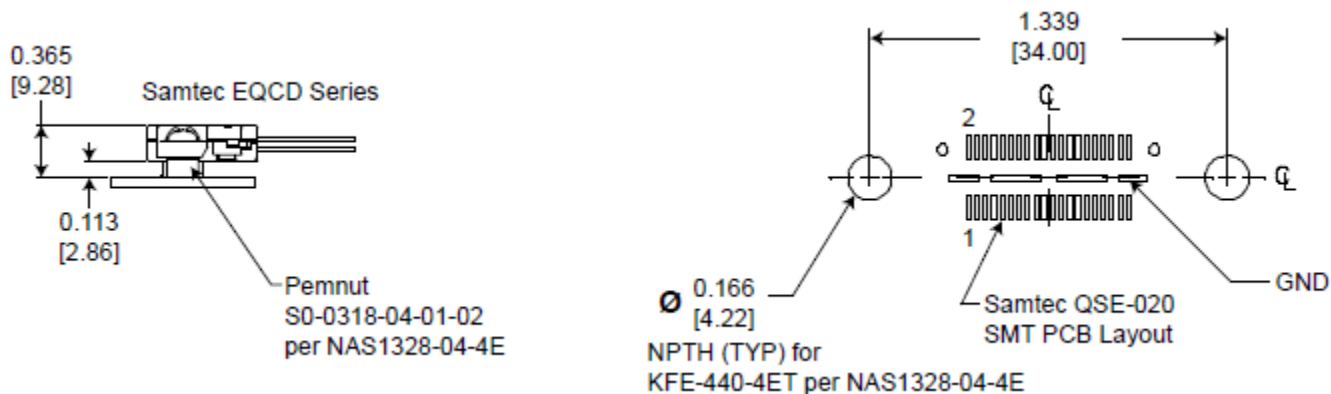

SAMTEC EQCD PIN ASSIGNMENTS

PIN	Function	Port	PIN	Function	Port
1	GND	ALL	2	GND	ALL
3	RX+	0	4	LOS	0
5	RX-	0	6	TX_DIS	0
7	GND	ALL	8	GND	ALL
9	GND	ALL	10	VCC	ALL
11	GND	ALL	12	VCC	ALL
13	GND	ALL	14	GND	ALL
15	TX-	0	16	LOS_0	1
17	TX+	0	18	TX_DIS	1
19	GND	ALL	20	GND	ALL
21	GND	ALL	22	VCC	ALL
23	RX+	1	24	VCC	ALL
25	RX-	1	26	GND	ALL
27	GND	ALL	28	NC	-
29	GND	ALL	30	NC	-
31	GND	ALL	32	NC	-
33	GND	ALL	34	NC	-
35	TX-	1	36	NC	-
37	TX+	1	38	NC	-
39	GND	ALL	40	NC	-

D38999 SIZE 19-18 DUAL PORT OPTICAL TRANSCEIVER, 850nm, ARINC 818, 801, 803 & 804

APPLICATION SCHEMATIC

For Xilinx Rocket I/O Interfaces

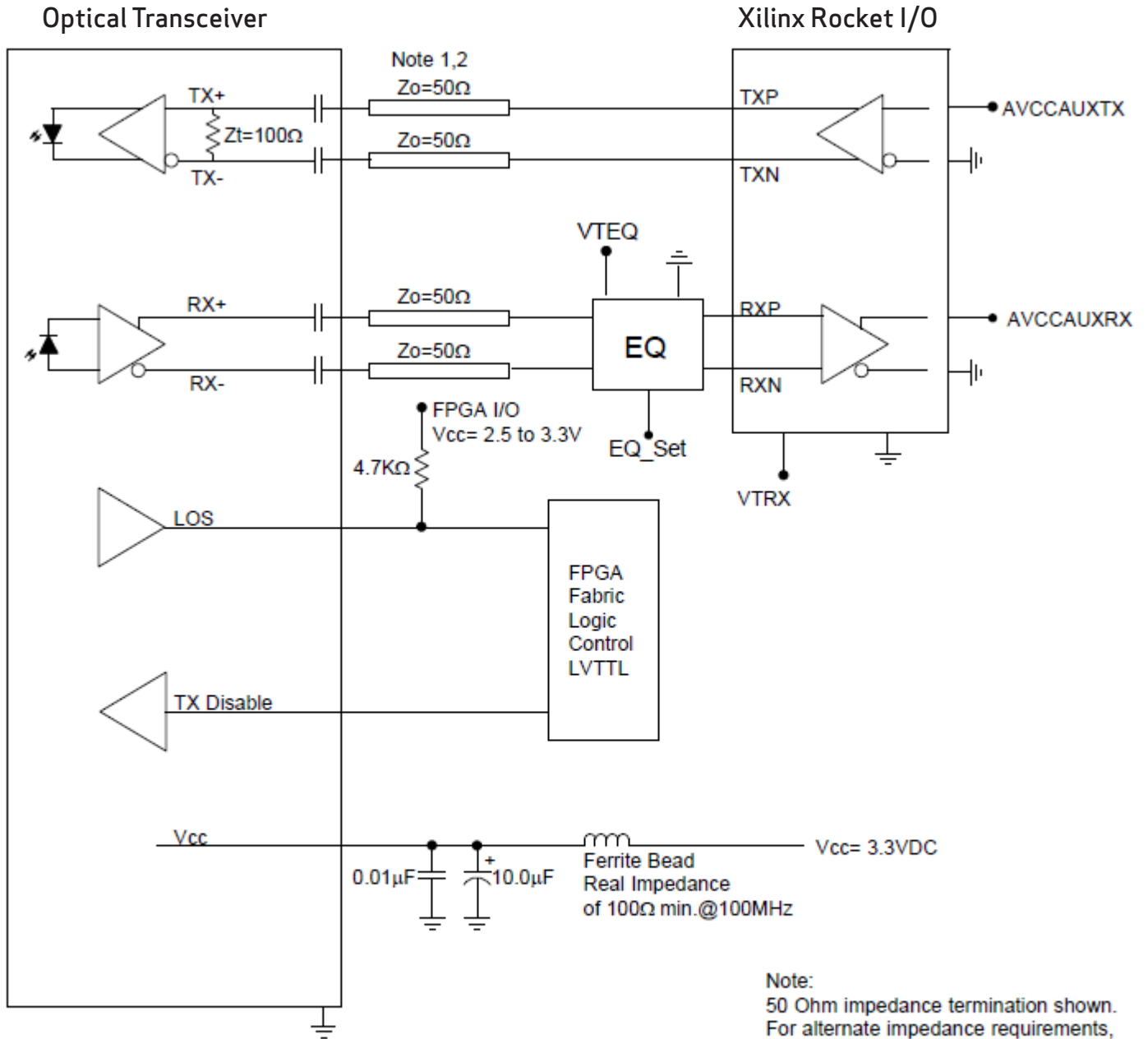

Note:
50 Ohm impedance termination shown.
For alternate impedance requirements,
please consult the Factory.

Typical application schematic shown
For alternate applications or termination
techniques, please consult the Factory

D38999 SIZE 19-18 DUAL PORT OPTICAL TRANSCEIVER, 850nm, ARINC 818, 801, 803 & 804

APPENDIX A1 Mating Fiber Optic Cable - Plug Configuration

FIBER OPTIC CABLE PLUG - SOCKET INSERT

Esterline Souriau Part Number = 8D5Q19x84SN621L x = Finish

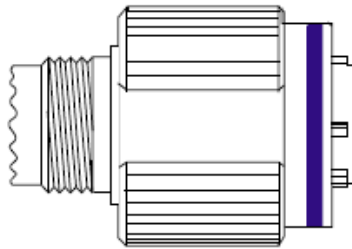

FIBER OPTIC TERMINUS

ARINC 801 Terminus

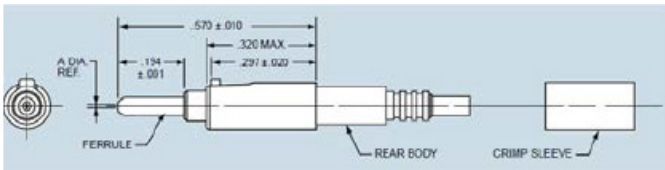

** defined by fiber optic cable configuration
 *** Amphenol part number CF-198148-126

ARINC 801 SIZE 8 CAVITY REDUCER

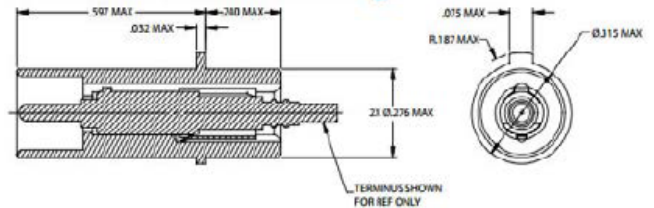

** defined by fiber optic cable configuration
 *** Amphenol part number FRPA6000

D38999 SIZE 19-18 DUAL PORT OPTICAL TRANSCEIVER, 850nm, ARINC 818, 801, 803 & 804

APPENDIX A2 PART NUMBER OPTIONS

Dagger D38999/19-18 Series

P13 x - 4 x 1 K - F x x - L

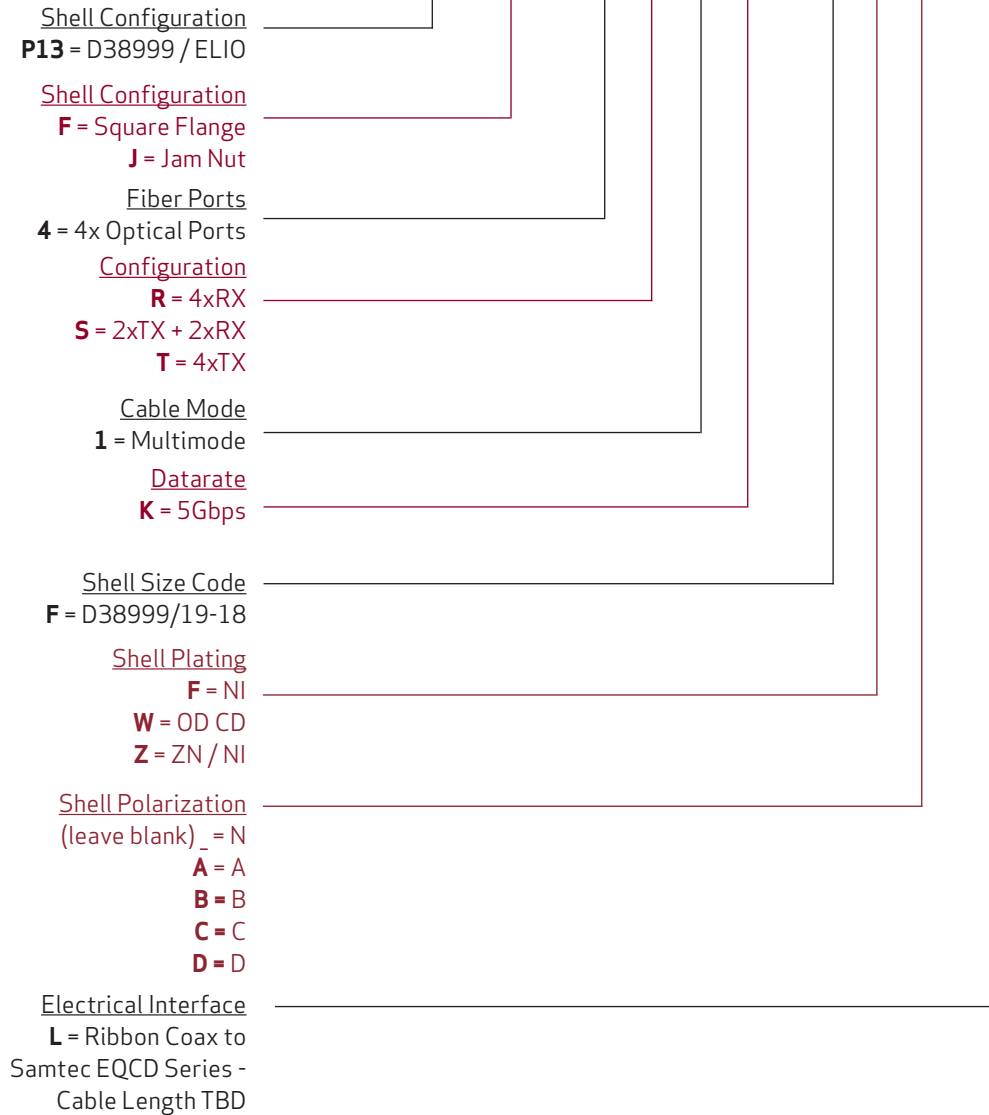

192 Bob Fitz Road, Johnson City, TN 37615
 salesmp@moog.com
 moogprotokraft.com