

# Lightning Series

Mil-Dtl-38999 Optical Transceiver,  
Fast Ethernet Applications,  
Multimode, 1310nm, LED

**Single Port, Flange Receptacle**

## FEATURES

- Compliant with IEEE-802.3u/100Base-FX Fast Ethernet
- Optical fiber link distances up to 2.0 Kilometers
- Maximum channel bit error rate less than  $2.5 \times 10^{-10}$
- RX Signal Detect functions indicate loss of optical signal
- Operating temperature range from  $-40^{\circ}\text{C}$  to  $+85^{\circ}\text{C}$
- Shock, vibration and immersion resistant per Mil-Std-810
- Olive drab cadmium over electroless nickel shielding meets stringent EMI / RFI performance requirements
- Mil-T-29504 compliant optical fiber interface
- Connector insert configuration conforms to Mil-Std-1560

## APPLICATIONS

Lightning series bulkhead mounted optical transceivers enable high speed network communications over long distances in harsh environments.

- Fast Ethernet switches, terminals and media converters
- Industrial automation and process control systems
- Traffic control and campus security networks

The Mil-Dtl-38999, Series III aluminum shell provides a sealed optical interface that is water-tight to Mil-Std-810 / IP67 / NEMA-4x when mated.

The multimode optical fiber interface supports applications where copper cable link distance, bandwidth limitations, weight or bulk make the use of twisted pair, coax, twinax or quadax copper conductors unacceptable.



One TX & One RX Channel Operating from 1.0 to 200.0Mbps

## DESCRIPTION

Lightning series optical fiber transceivers consist of optoelectronic transmitter and receiver functions integrated into a bulkhead mounted Mil-Dtl-38999 series III receptacle connector. The optical transmitters are 1310nm LED's. The transmitter input lines are driven with differential LVPECL signals applied to the transmitter (TX+ and TX-) lines. Temperature compensated LED drivers convert the transmitter input signals to suitable LED modulation currents. The optical receivers consist of PIN and preamplifier assemblies and limiting post-amplifiers. Outputs from the receivers consist of differential LVPECL data signals on the receiver (RX+ and RX-) lines and single ended LVPECL indicators on the Signal Detect (SD) lines.

The receiver data lines are squelched upon loss of the incoming optical signals, preventing errant data generation when invalid incoming optical inputs are presented to the transceiver.

The electrical interface to the Lightning series bulkhead optical transceivers is a 0.050" x 0.100" solder pin field enabling connection to a printed circuit assembly.

Lightning series optical fiber transceivers are vibration isolated, environmentally hardened components ready for use in harsh environment applications.

- Sealed against liquid and solid contaminants
- Shock and vibration resistant

## ORDERING INFORMATION

Application	Product Number
Fast Ethernet	P38F-2L1C-DW

Single Port Lightning Series Mil-Dtl-38999 Optical Transceiver  
Fast Ethernet Applications, Multimode, 1310nm, LED

## ABSOLUTE MAXIMUM RATINGS

Absolute maximum limits mean that no catastrophic damage will occur if the product is subjected to these ratings for short periods, provided each limiting parameter is in isolation and all other parameters have values within the performance specification. It should not be assumed that limiting values of more than one parameter can be applied to the product at the same time.

Parameter	Symbol	Minimum	Typical	Maximum	Unit
Storage Temperature	$T_s$	-55		+100	°C
Supply Voltage	$V_{CC}$	-0.5		+4.5	V
Data Input Voltage	$V_I$	-0.5		$V_{CC}$	V
Differential Input Voltage (p-p)	$V_D$			2.0	V
RX Output Current	$I_o$			50	mA

## RECOMMENDED OPERATING CONDITIONS

Parameter	Symbol	Minimum	Typical	Maximum	Unit
Operating Temperature	$T_A$	-40		+85	°C
Supply Voltage	$V_{CC}$	+3.135		+3.465	V
TX Common Mode Voltage	$V_{CM}$		2.0		V
TX Differential Input Voltage (p-p)	$V_D$	0.35		1.25	V
Power Supply Noise (p-p)	$N_P$			200	mV

## SPECIFICATIONS COMPLIANCE

Requirement	Feature	Condition	Notes
MIL-STD-883	ESD	Class II	2200V
MIL-STD-810	Vibration	30.0g	18mS
MIL-STD-810	Shock	40.0g	6-9mS
MIL-STD-810	Immersion	1.0 meter	2.0Hours
MIL-STD-1344	Flame Resistance	Method 1012	30 Seconds
MIL-STD-1344	Damp Heat	10 Cycles	24 Hours
MIL-STD-38999	Mating Durability	500 Cycles	<0.5dB Change

## MATERIALS

Item	Detail	Notes
Shell	Aluminum Alloy	
Shell Plating	Olive Drab Cadmium over Nickel	QQ-P-416, QQ-N-290
Insert	Thermoplastic	
Interfacial Seal	Elastomer	
Alignment Sleeves	Composite Polymer	
Printed Circuits	Polyimide / FR-4	Mil-P-31032 Type 4

Single Port Lightning Series Mil-Dtl-38999 Optical Transceiver  
Fast Ethernet Applications, Multimode, 1310nm, LED

**TRANSMITTERS  $T_A$  = Operating Temperature Range,  $V_{CC} = 3.135V$  to  $3.465V$**

Parameter	Symbol	Minimum	Typical	Maximum	Unit
Optical Output Power <sup>1</sup>	$P_o$	-19.0		-14.0	dBm
Optical Output Wavelength	$\lambda_{OUT}$	1260	1310	1380	nM
Extinction Ratio	ER	10.0			dB
Optical Rise / Fall Time (10% to 90%)	$t_{R,F}$	0.6		3.0	nS
Duty Cycle Distortion (p-p)	DCD			1.0	nS
Data Dependent Jitter (p-p)	DDJ			0.6	nS
Random Jitter (p-p)	RJ			0.76	nS

1. BER=2.5x10<sup>-10</sup>@125Mbps, PRBS 2<sup>7</sup>-1, NRZ, Compliant with FDDI PMD ISO / IEC 9314-3 and IEEE-802.3u tested with 62.5/125μ multimode fiber.

**RECEIVERS  $T_A$  = Operating Temperature Range,  $V_{CC} = 3.135V$  to  $3.465V$**

Parameter	Symbol	Minimum	Typical	Maximum	Unit
Optical Sensitivity <sup>1</sup>	$P_i$	-31.5		-8.0	dBm
Optical Wavelength	$\lambda_{IN}$	1100		1590	nM
Contributed Duty Cycle Distortion (p-p)	DCD			0.4	nS
Contributed Data Dependent Jitter (p-p)	DDJ			1.0	nS
Contributed Random Jitter (p-p)	RJ			2.14	nS
Signal Detect Assert Time	$t_{SDAS}$		<10	100	μS
Signal Detect Deassert Time	$t_{SDDA}$		<10	350	μS
Signal Detect Threshold Decreasing Light	LSTD	-45.0		-32.5	dBm
Increasing Light	LSTI	-45.0		-32.0	
Signal Detect Hysteresis	HYS	1.5	2.25	3.5	dB
RX Data Output - Low	$V_{OL}-V_{CC}$	-1.810		-1.475	V
RX Data Output - High	$V_{OH}-V_{CC}$	-1.165		-0.880	V

1. BER=2.5x10<sup>-10</sup>@125Mbps, PRBS 2<sup>7</sup>-1, NRZ, Compliant with FDDI PMD ISO / IEC 9314-3 and IEEE-802.3u tested with 62.5/125μ multimode fiber.

**SUPPLY CURRENT  $T_A$  = Operating Temperature Range,  $V_{CC} = 3.135V$  to  $3.465V$**

Parameter	Symbol	Minimum	Typical	Maximum	Unit
Supply Current per Port	$I_{CCT}$		160	245	mA

**OPTICAL FIBER LINK DISTANCES**

Application	Fiber Specification	Distance
Fast Ethernet - IEEE 802.3u FDDI PMD ISO / IEC 9314-3	62.5/125μ - 500MHz*Km or 50/125μ - 500MHz*Km	2.0Km

Single Port Lightning Series Mil-Dtl-38999 Optical Transceiver  
Fast Ethernet Applications, Multimode, 1310nm, LED

**OUTLINE DRAWING**

Dimensions are shown as: inches (mm)

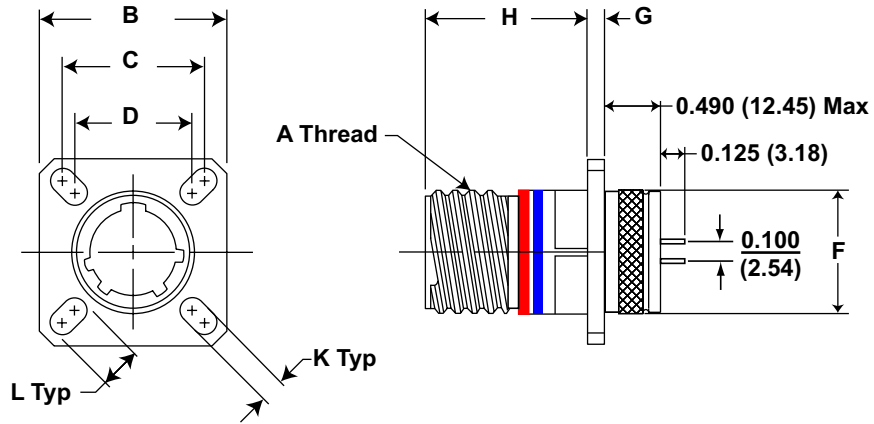

**Outline Dimensions**

Shell Size Code	Shell Size	A Thread	B Sq Max	C Bsc	D Bsc	F Max	G Max	H Max	K	L
D	15	1.0000-.1P-.3L-TS-2A	1.231 (31.3)	0.969 (24.6)	0.906 (23.0)	1.015 (25.78)	0.098 (2.5)	0.820 (20.8)	0.128 (3.3)	0.173 (4.4)

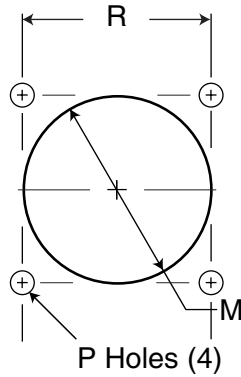

**Panel Cutout Dimensions**

Rear Panel Mounting Only

Shell Size Code	Shell Size	M Min	P Holes	R Bsc
D	15	1.047 (26.59)	0.133 (3.4) 0.123 (3.1)	0.969 (24.6)

Single Port Lightning Series Mil-Dtl-38999 Optical Transceiver  
Fast Ethernet Applications, Multimode, 1310nm, LED

**OPTICAL TRANSCEIVER INSERT ARRANGEMENT**

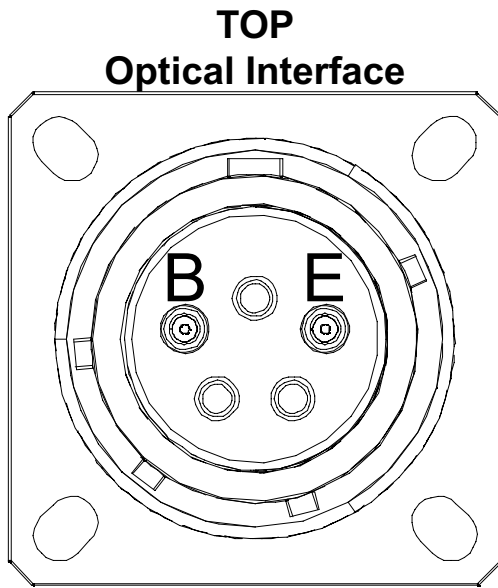

Front face of the optical transceiver insert shown, fiber optic cable plug opposite - see Appendix A2 for details

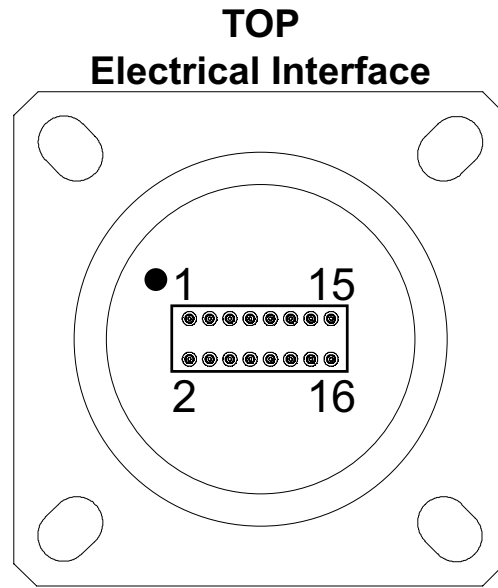

Back face of the optical transceiver insert shown - see Printed Circuit Board Footprint and Electrical Pin Assignment pages for details

**OPTICAL TRANSCEIVER RECEPTACLE PORT ASSIGNMENTS**

FUNCTION	OPTICAL		ELECTRICAL	
PORT NUMBER	TX	RX	TX (-,+)	RX (-,+)
0	B	E	13,11	5,3

**RECEPTACLE PROTECTION CAPS**

**\*MIL-DTL-38999/33 PROTECTION CAP PART NUMBERS**

MS RECEPTACLE CAP P/N

See Appendix A1

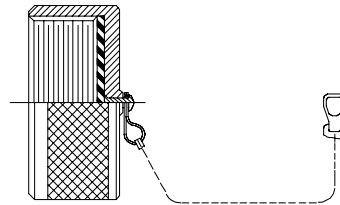

\*See DSCC or SAE QPL for Approved Suppliers

Single Port Lightning Series Mil-Dtl-38999 Optical Transceiver  
Fast Ethernet Applications, Multimode, 1310nm, LED

**PRINTED CIRCUIT BOARD FOOTPRINT**

Mil-Dtl-38999 Series III Size 15-5  
Dimensions are shown as: inches (mm)

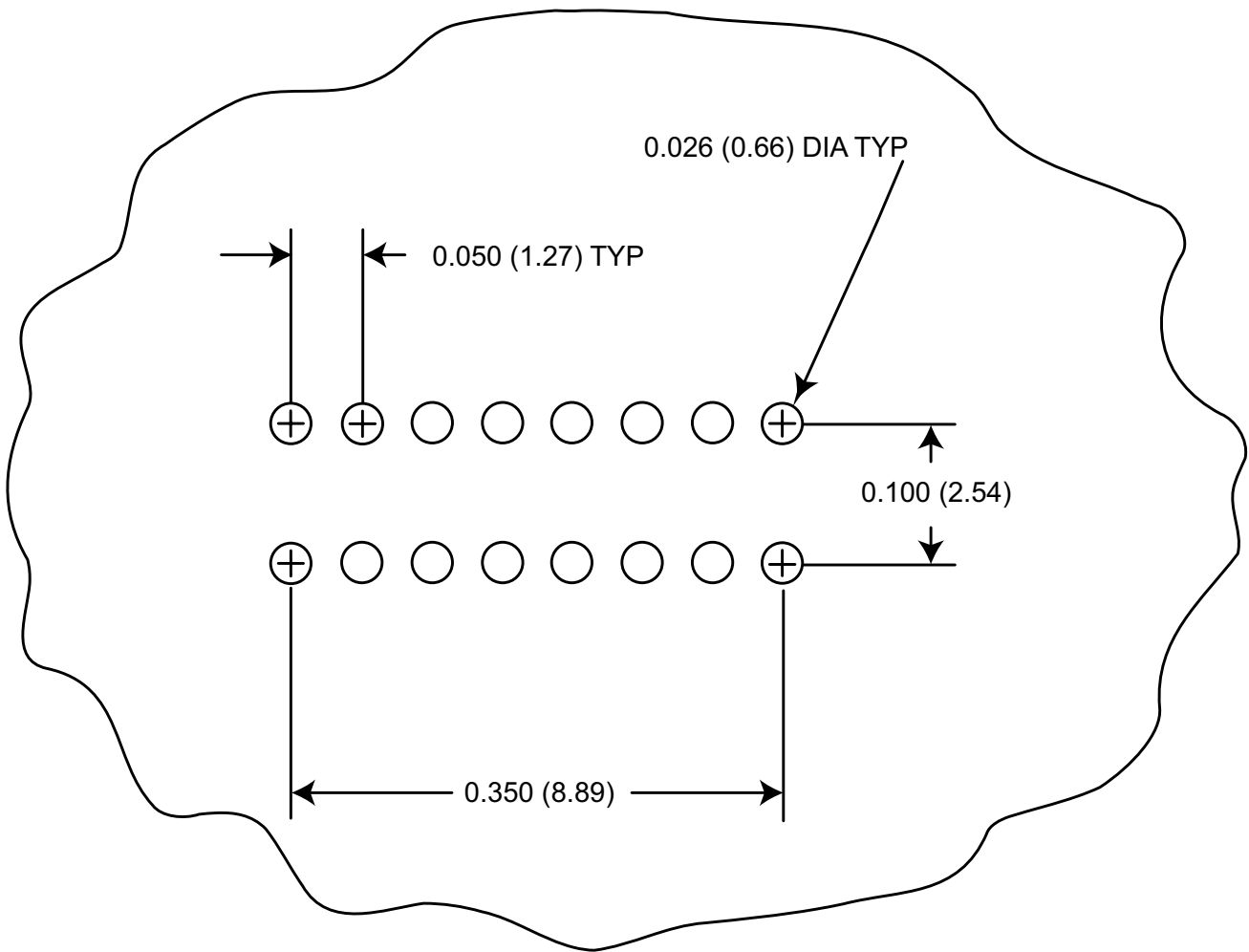

Single Port Lightning Series Mil-Dtl-38999 Optical Transceiver  
 Fast Ethernet Applications, Multimode, 1310nm, LED

**ELECTRICAL PIN ASSIGNMENTS**

Mil-Dtl-38999 Series III, Shell Size 15-5

Pin Number	Symbol	Description	Logic Family
1	RX Vcc	Receiver Power Supply	N/A
2	GND	Receiver Signal Ground	N/A
3	RX+	Receiver Data Output	LVPECL
4	GND	Receiver Signal Ground	N/A
5	RX-	Receiver Data Output	LVPECL
6	GND	Receiver Signal Ground	N/A
7	GND	Receiver Signal Ground	N/A
8	GND	Receiver Signal Ground	N/A
9	GND	Transmitter Signal Ground	N/A
10	GND	Transmitter Signal Ground	N/A
11	TX+	Transmitter Data Input	LVPECL
12	GND	Transmitter Signal Ground	N/A
13	TX-	Transmitter Data Input	LVPECL
14	GND	Transmitter Signal Ground	N/A
15	TX Vcc	Transmitter Power Supply	N/A
16	SD	Signal Detect - Output Satisfactory Optical Input: Logic "1" Output Unsatisfactory Optical Input: Logic "0" Output	LVPECL

Single Port Lightning Series Mil-Dtl-38999 Optical Transceiver  
Fast Ethernet Applications, Multimode, 1310nm, LED

**APPLICATION SCHEMATIC**  
For +3.3V LVPECL PHY Circuits

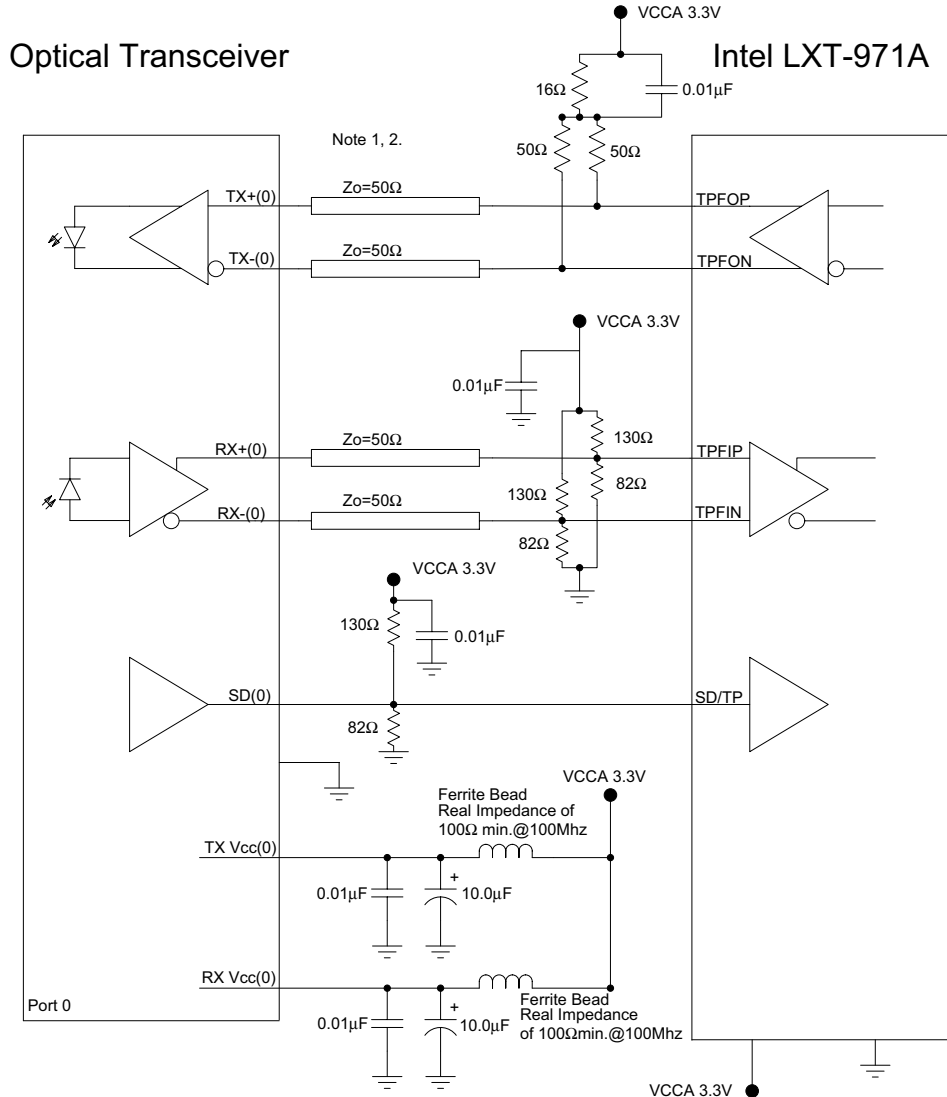

Typical application schematic shown.  
For Alternative applications or termination techniques  
Please consult the Factory

Note: 1  
When using controlled impedance cable (Coaxial cable),  
lengths of >1meter are obtainable.

Note: 2  
50 ohm impedance termination shown.  
For other impedance requirements please consult the factory

All Protokraft statements, technical information and recommendations related to the products herein are based upon information believed to be reliable or accurate. However, the accuracy or completeness thereof is not guaranteed, and Protokraft assumes no responsibility for any inaccuracies. The user assumes all risks and liability whatsoever in connection with the use of a product or its application. Protokraft reserves the right to change at any time, without prior or subsequent notice, the design, specifications, function, fit or form of its products described herein, including withdrawal at any time of a product offered for sale herein. Protokraft makes no representations that the products herein are free from any intellectual property claims of others. Protokraft and the Protokraft logo are trademarks of Protokraft, LLC. Other trademarks are the property of their respective holders. Contact Protokraft for prices and availability. For the most recent version of this data sheet, please go to the Protokraft website at <http://www.protokraft.com>. In case of discrepancy, the web version takes precedence over any printed literature. ©2004 Protokraft, LLC. All rights reserved.



Single Port Lightning Series Mil-Dtl-38999 Optical Transceiver  
Fast Ethernet Applications, Multimode, 1310nm, LED

# APPENDIX A1

## RECEPTACLE PROTECTION CAPS

### \*MIL-DTL-38999/33 PROTECTION CAP PART NUMBERS

MS RECEPTACLE CAP P/N

\*D38999/33W15R

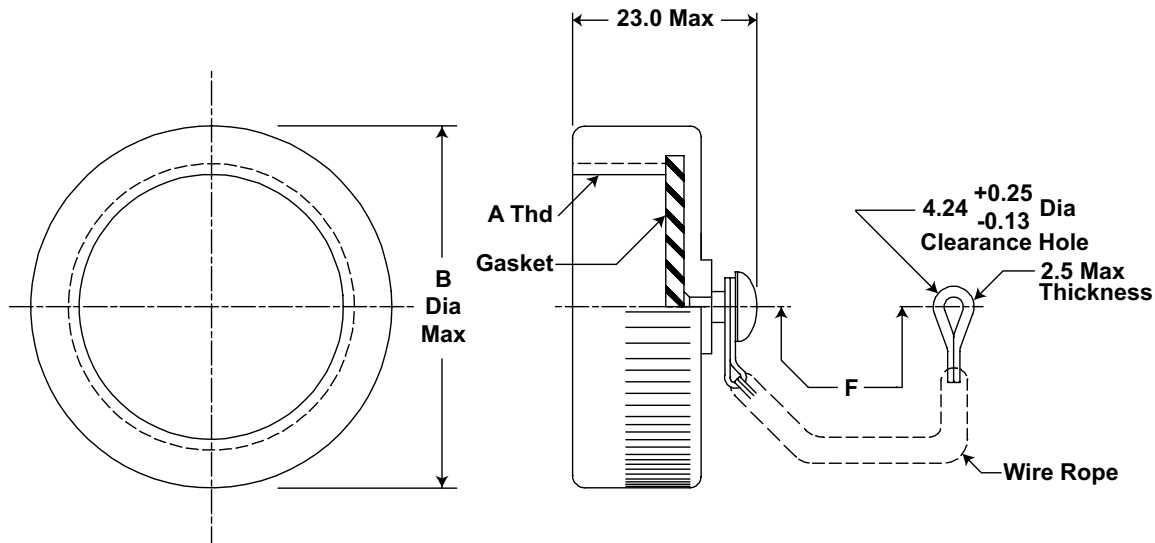

\*See DSCC or SAE QPL for Approved Suppliers  
<http://www.dsccl.dla.mil/programs/qmlqpl/QPLdetail.asp?QPL=38999>

### MIL-DTL-38999/33 Outline Dimensions - mm

Shell Size Code	Shell Size	A Thread (inches)	B Max Dia	F
D	15	1.0000-.1P-.3L-TS-2A	32.0	+13.0 -7.0

## APPENDIX A2

### MIL-DTL-38999 FIBER OPTIC CABLE PLUG / MIL-T-29504 PIN TERMINI

\*See DSCC or SAE QPL for Approved Suppliers

<http://www.dscclia.mil/programs/qmlqpl/QPLdetail.asp?QPL=38999>

#### \*D38999 PLUG - PIN INSERT

##### MIL-DTL-38999 CABLE PLUG

MS PLUG P/N

\*D38999/26WD5PN

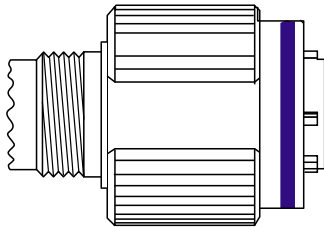

#### \*FIBER OPTIC PIN TERMINUS

##### MIL-T-29504 PIN TERMINUS

MS PIN TERMINUS P/N

\*M29504/04-xxxx\*\*



\*\*defined by fiber optic cable configuration

#### D38999 PLUG PORT FUNCTIONS

PORT NUMBER	TX	RX
0	B	E

#### \*CABLE PROTECTION CAP

##### D38999/32 PLUG PROTECTION CAP

MS PLUG CAP P/N

\*D38999/32W15N

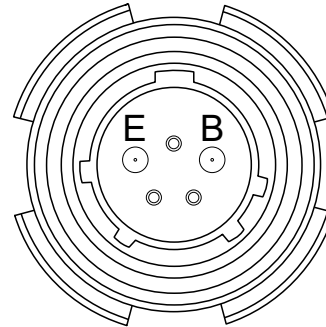
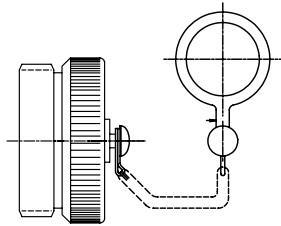

Front face of the optical cable plug pin insert shown. Transceiver insert opposite.

#### \*CABLE BACKSHELL

##### MIL-C-85049 CABLE BACKSHELL

MS BACKSHELL P/N

\*MS85049/xxxxxx\*\*

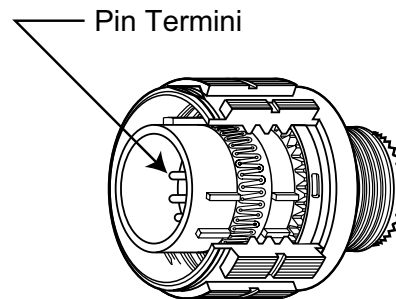
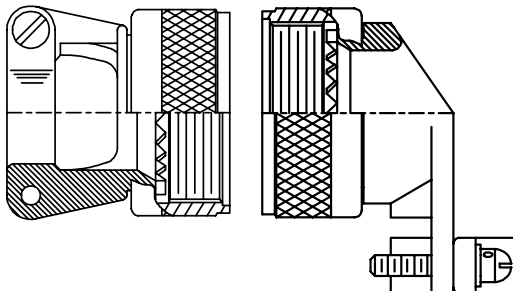

\*\*Straight or angled backshell - defined by application / mounting configuration

**MOOG**  
PROTOKRAFT

192 Bob Fitz Road, Johnson City, TN 37615  
salesmp@moog.com  
moogprotokraft.com