

Lightning Series

MIL-DTL-38999 Optical Transceiver,
FC, Ethernet & sFPDP Applications,
Multimode, 850nm VCSELs

Dual Port, Receptacle

FEATURES

- Suitable for Gigabit Ethernet, 1x/2xFibre Channel, ARINC 818 and sFPDP applications from 50Mbps to 3.2Gbps
- Optical fiber link distances up to 550 Meters (50/125µ 500MHz*Km MMF)
- Maximum optical channel bit error rate less than 1×10^{-12}
- Operating temperature range from -40°C to +85°C
- Shock, vibration and immersion resistant per MIL-STD-810
- Olive drab cadmium over electroless nickel plating meets stringent corrosion resistance specifications
- Aluminum alloy MIL-DTL-38999 housings are strong, durable, and light weight
- MIL-T-29504 compliant optical fiber connector interface
- Samtec EQCD Series electrical connector for SMT interface

APPLICATIONS

Lightning series bulkhead mounted optical transceivers enable high speed network communications over long distances in harsh environments.

- Fast or Gigabit Ethernet switches and peripherals
- Fibre Channel switches and peripherals
- sFPDP data links
- ARINC 818 Video displays and drivers

The MIL-DTL-38999, Series III shell provides a sealed optical interface that is water-tight to MIL-STD-810 / IP67 / NEMA-4x when mated.

The multimode optical fiber interface supports applications where copper cable link distance, bandwidth, weight or bulk make the use of twisted pair, twinax or quadrx copper conductors unacceptable.

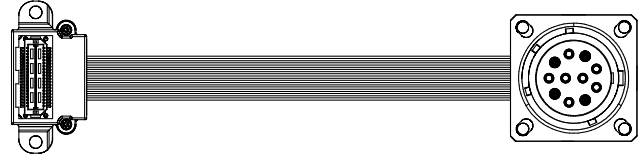

Two TX & Two RX Channels Operating from 50Mbps to 3.2Gbps

DESCRIPTION

Lightning series optical fiber transceivers consist of optoelectronic transmitter and receiver functions integrated into a bulkhead mounted MIL-DTL-38999, Series III receptacle connector. The optical transmitters are 850nm VCSEL lasers. The transmitter input lines are driven with differential CML signals applied to the transmitter (TX+ and TX-) lines. Dual loop, temperature compensated, VCSEL drivers convert the transmitter input signals to suitable VCSEL bias and modulation currents.

The optical receivers consist of PIN and preamplifier assemblies and limiting post-amplifiers. Outputs from the receivers consist of differential CML data signals on the receiver (RX+ and RX-) lines and single ended CMOS indicator functions on the Loss of Signal (LOS) lines. The receiver data lines are squelched upon LOS assertion, preventing errant data generation when an invalid incoming optical signal is presented to the transceiver.

The electrical interface to the Lightning series optical transceivers is a ribbon coax to Samtec EQCD high density cable assembly enabling SMT interconnection to a customer's backplane, motherboard or daughtercard.

Lightning series optical fiber transceivers are vibration isolated, environmentally hardened components designed for use in harsh environment applications.

ORDERING INFORMATION

Application	Part Number
GbE, 1x/2xFC, Flange	P38F-4S1D-FW-Lxxx
sFPDP / ARINC 818, Flange	P38F-4S1E-FW-Lxxx
GbE, 1x/2xFC, Jam Nut	P38J-4S1D-FW-Lxxx
sFPDP / ARINC 818, Jam Nut	P38J-4S1E-FW-Lxxx

See page 6 for standard part number / cable length options

Dual Port Lightning Series MIL-DTL-38999 Optical Transceiver,
GbE, 1x/2xFC or Serial FPDP Applications, Multimode, 850nm VCSELs

ABSOLUTE MAXIMUM RATINGS

Absolute maximum limits mean that no catastrophic damage will occur if the product is subjected to these ratings for short periods, provided each limiting parameter is in isolation and all other parameters have values within the performance specification. It should not be assumed that limiting values of more than one parameter can be applied to the product at the same time.

Parameter	Symbol	Minimum	Typical	Maximum	Unit
Storage Temperature	T_s	-55		+100	°C
Supply Voltage	V_{CC}	-0.5		+4.5	V
TX_DIS Input Voltage	V_I	-0.5		$V_{CC} + 0.5$	V
Differential Input Voltage (p-p)	V_D			2.2	V
RX Output Current	I_o			50	mA

RECOMMENDED OPERATING CONDITIONS

Parameter	Symbol	Minimum	Typical	Maximum	Unit
Operating Temperature	T_A	-40		+85	°C
Supply Voltage	V_{CC}	+3.135		+3.465	V
TX Common Mode Voltage	V_{CM}		2.0		V
TX Differential Input Voltage (p-p)	V_D	0.25		2.2	V
Power Supply Noise (p-p)	N_p			200	mV

SPECIFICATIONS COMPLIANCE

Requirement	Feature	Condition	Notes
MIL-STD-883	ESD	Class II	2200V
MIL-STD-810	Vibration	3.8g ² /Hz	43G rms
MIL-STD-810	Shock	40.0g	6-9mS
MIL-STD-810	Immersion	1.0 meter	2 .0Hours
MIL-STD-1344	Flame Resistance	Method 1012	30 Seconds
MIL-STD-1344	Damp Heat	10 Cycles	24 Hours
MIL-STD-38999	Mating Durability	500 Cycles	<0.5dB Change
FDA / CDRH / IEC-825-1	Eye Safety	Class 1	No Safety Interlocks Required

MATERIALS

Item	Detail	Notes
Shell	Aluminum Alloy	
Shell Plating	Olive Drab Cadmium over Nickel	QQ-P-416, QQ-N-290
Insert	Thermoplastic	
Interfacial Seal	Elastomer	
Alignment Sleeves	Composite Polymer	
Printed Circuits	Polyimide / FR-4	Mil-P-31032 Type 4

Dual Port Lightning Series MIL-DTL-38999 Optical Transceiver,
GbE, 1x/2xFC or Serial FPDP Applications, Multimode, 850nm VCSELs

OPTICAL TRANSMITTERS T_A = Operating Temperature Range, V_{CC} = 3.135V to 3.465V

Parameter	Symbol	Minimum	Typical	Maximum	Unit
Optical Output Power (BER<10 ⁻¹²)	P_o	-9.5		-4.0	dBm
Optical Output Wavelength	λ_{OUT}	830	850	860	nM
Spectral Width	$\Delta\lambda_{RMS}$			0.85	nM
Extinction Ratio	ER	9.0			dB
Optical Rise, Fall Time (20% to 80%)	$t_{R,F}$			150	pS

OPTICAL RECEIVERS T_A = Operating Temperature Range, V_{CC} = 3.135V to 3.465V

Parameter	Symbol	Minimum	Typical	Maximum	Unit
Optical Sensitivity (BER<10 ⁻¹² , ER=9.0) P38x-xxxD-xx @ 125Mbps to 1.25Gbps P38x-xxxD-xx @ 2.125Gbps P38x-xxxE-xx @ 2.5Gbps to 3.2Gbps	P_i	-17.0 -15.0 -14.0		0.0	dBm
Optical Wavelength	λ_{IN}	830		860	nM
RX Data Output - Low	$V_{OL} - V_{CC}$	-1.810		-1.475	V
RX Data Output - High	$V_{OH} - V_{CC}$	-1.165		-0.880	V

POWER SUPPLY CURRENT T_A = Operating Temperature Range, V_{CC} = 3.135V to 3.465V

Parameter	Symbol	Minimum	Typical	Maximum	Unit
Supply Current per Port	I_{CCT}		100	140	mA

OPTICAL LINK DISTANCES

Protocol	62.5/125 μ 200MHz*Km	50/125 μ 500MHz*Km
2xFibre Channel - ANSI X3.297 FC-PI	150M	300M
Gigabit Ethernet - IEEE-802.3:2005	275M	550M
1xFibre Channel - ANSI X3.297 FC-PH-2	300M	500M

Dual Port Lightning Series MIL-DTL-38999 Optical Transceiver,
GbE, 1x/2xFC or Serial FPDP Applications, Multimode, 850nm VCSELs

OUTLINE DRAWING

Flange Mount Option

Dimensions are shown as: inches [mm]

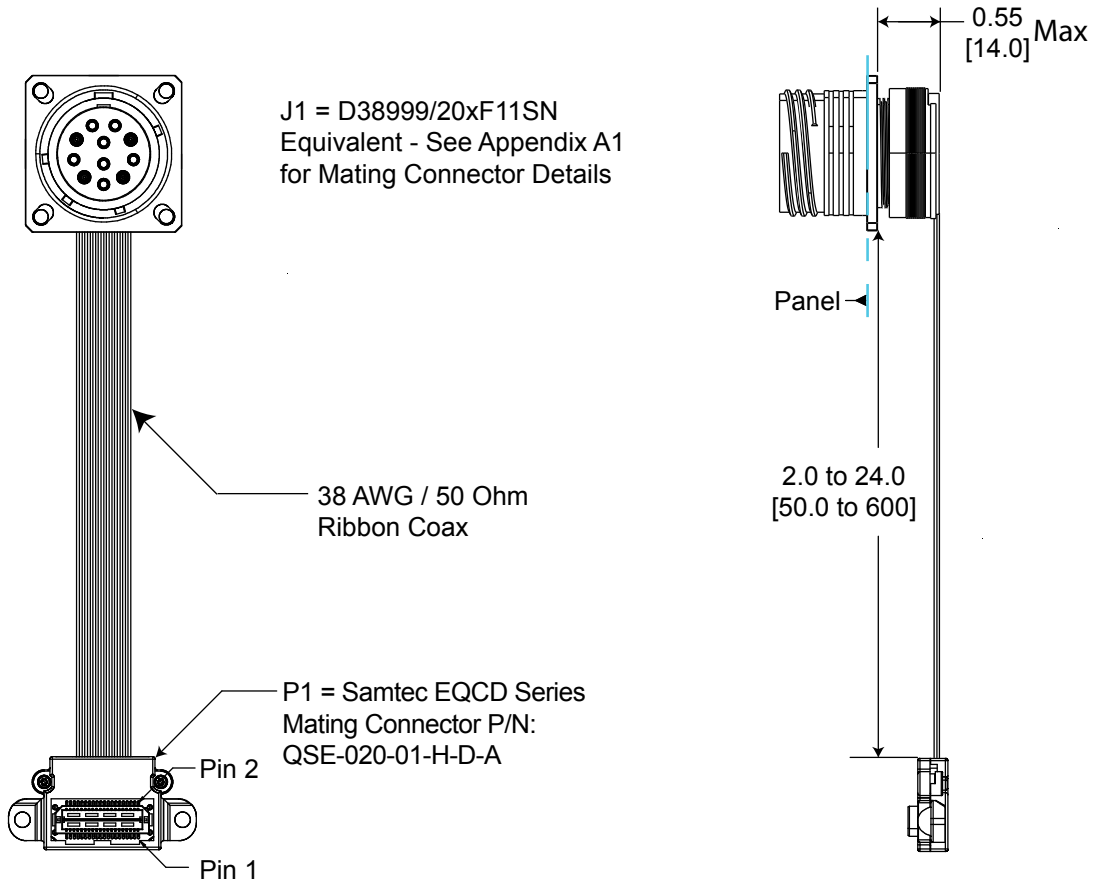

Panel Cutout Dimensions Rear Panel Mounting Only

Shell Size Code	Shell Size	M Min	P Holes	R Bsc
F	19	1.297 [32.94]	0.133 [3.4] / 0.123 [3.1]	1.156 [29.4]

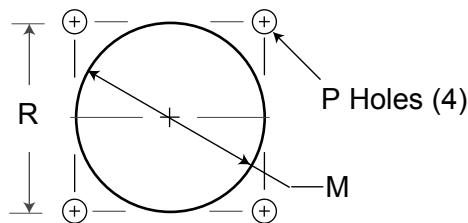

Part Number = *P38F-4xxx-Fx-Lxxx

*see page 6 for part number / cable length options and page 11 for complete ordering options

Dual Port Lightning Series MIL-DTL-38999 Optical Transceiver,
GbE, 1x/2xFC or Serial FPDP Applications, Multimode, 850nm VCSELs

OUTLINE DRAWING

Jam Nut Option

Dimensions are shown as: inches [mm]

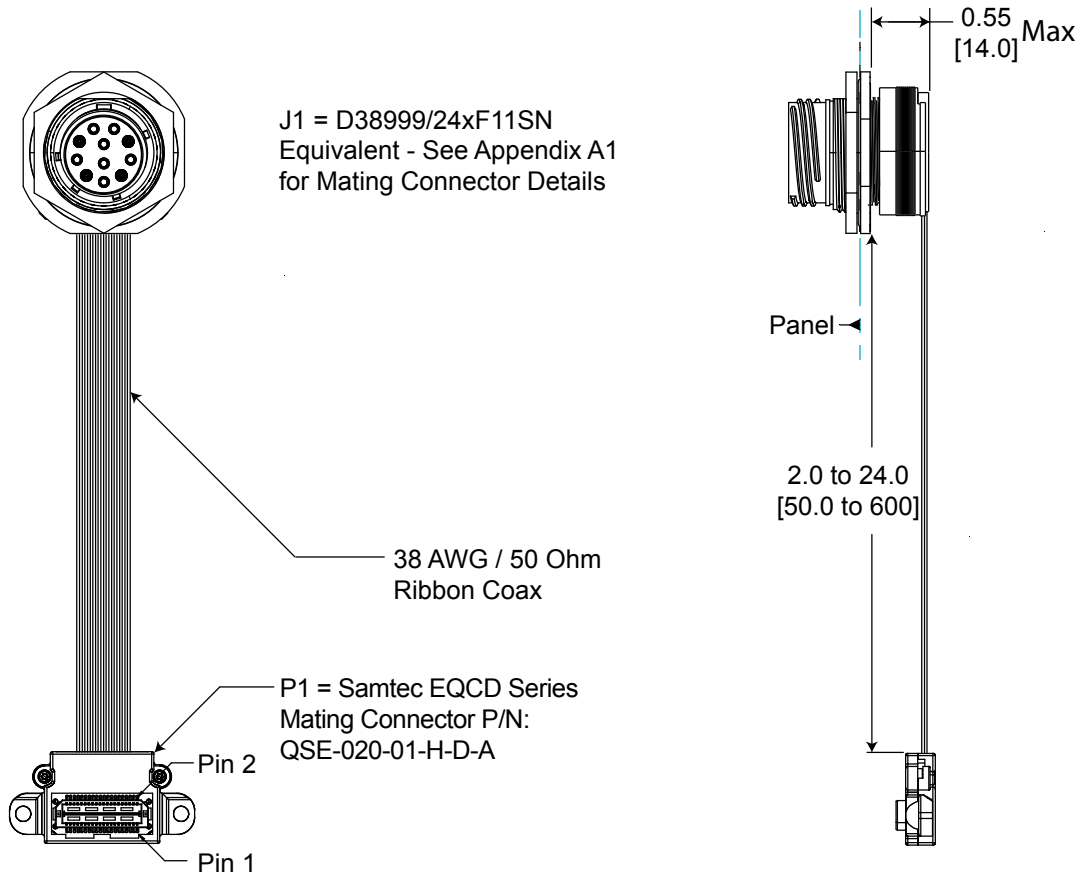

Panel Cutout Dimensions

Shell Size Code	Shell Size	D1 Min	D2 Min
F	19	1.385 [35.18]	1.335 [33.91]

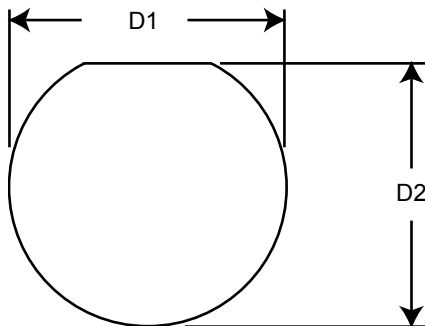

Part Number = *P38J-4xxx-Fx-Lxxx

*see page 6 for part number / cable length options and page 11 for complete ordering options

Dual Port Lightning Series MIL-DTL-38999 Optical Transceiver,
GbE, 1x/2xFC or Serial FPDP Applications, Multimode, 850nm VCSELs

OUTLINE DRAWING

Cable Length Options

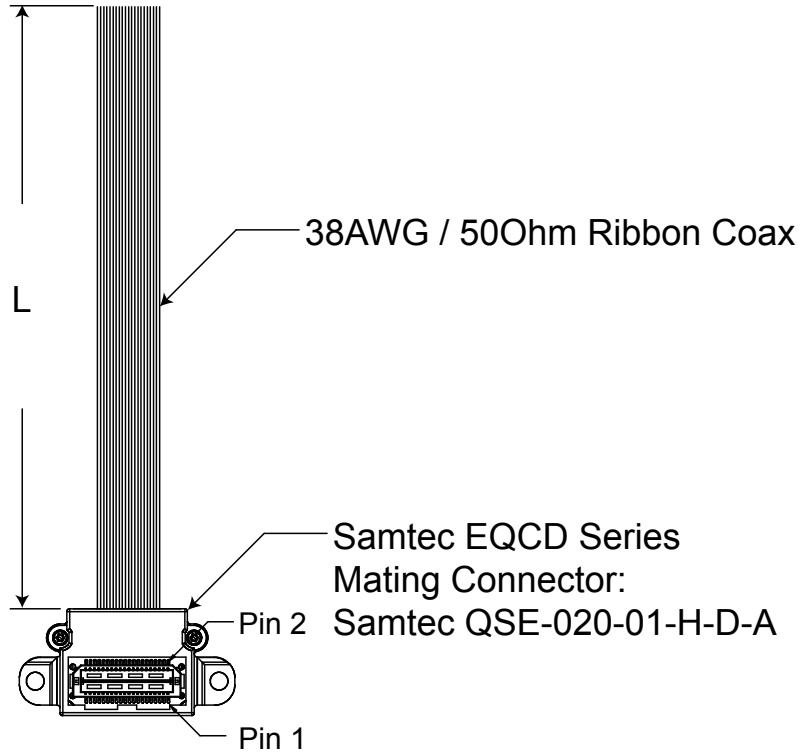

Ribbon Coax Cable Length Options

L (mm) +/- 6.0	ITEM #
50	xxxx-xxxx-xx-L050
100	xxxx-xxxx-xx-L100
150	xxxx-xxxx-xx-L150
200	xxxx-xxxx-xx-L200
250	xxxx-xxxx-xx-L250

Dual Port Lightning Series MIL-DTL-38999 Optical Transceiver,
GbE, 1x/2xFC or Serial FPDP Applications, Multimode, 850nm VCSELs

OPTICAL INSERT ARRANGEMENT

TOP

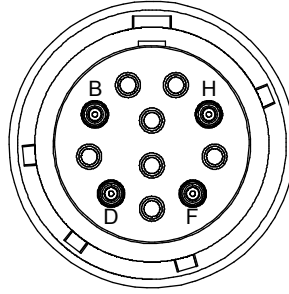

Front view of the D38999 optical
insert shown, fiber optic cable plug
opposite - see Appendix A1 for details

MIL-DTL-38999 OPTICAL INTERFACE

PORT NUMBER	TX	RX
0	H	F
1	B	D

Dual Port Lightning Series MIL-DTL-38999 Optical Transceiver,
GbE, 1x/2xFC or Serial FPDP Applications, Multimode, 850nm VCSELs

PRINTED CIRCUIT BOARD FOOTPRINT

All dimensions shown are for reference only: inches [mm]

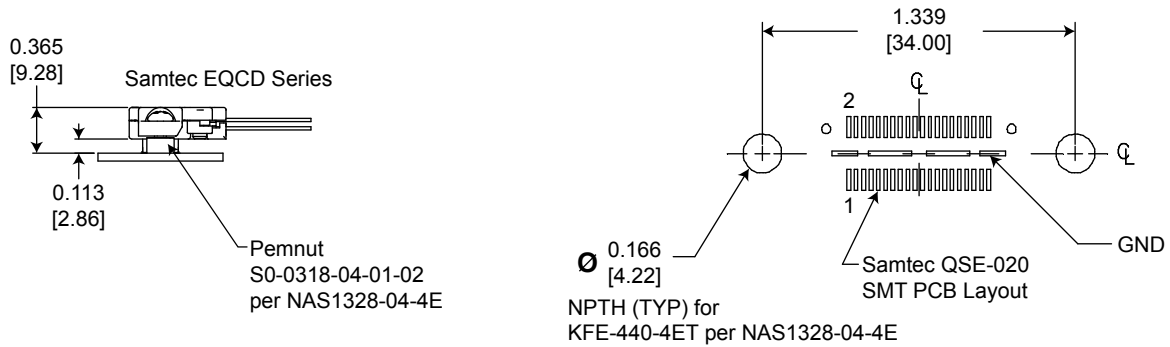

Samtec EQCD PIN ASSIGNMENTS

PIN #	PORT #	FUNCTION	Input / Output	Logic Family
1	0	LOS	Output	Open Drain CMOS Satisfactory Optical Input: Logic "0" Output Unsatisfactory Optical Input: Logic "1" Output
2	0-1	Signal Ground	NA	NA
3	0	RX-	Output	CML (Internally AC coupled)
4	NA	NC	NA	NA
5	0	RX+	Output	CML (Internally AC coupled)
6	0	TX_Dis	Input	CMOS Internal 4.7KΩ to 10.0KΩ pullup
7	0	TX-	Input	CML (Internally AC coupled) Internal 100Ω differential termination
8	0-1	V _{cc}	Input	3.135 to 3.465VDC
9	0	TX+	Input	CML (Internally AC coupled) Internal 100Ω differential termination
10	0-1	V _{cc}	Input	3.135 to 3.465VDC
11	1	LOS	Output	Open Drain CMOS Satisfactory Optical Input: Logic "0" Output Unsatisfactory Optical Input: Logic "1" Output
12	0-1	Signal Ground	NA	NA
13	1	RX-	Output	CML (Internally AC coupled)
14	NA	NC	NA	NA
15	1	RX+	Output	CML (Internally AC coupled)
16	1	TX_Dis	Input	CMOS Internal 4.7KΩ to 10.0KΩ pullup
17	1	TX-	Input	CML (Internally AC coupled) Internal 100Ω differential termination
18	0-1	V _{cc}	Input	3.135 to 3.465VDC
19	1	TX+	Input	CML (Internally AC coupled) Internal 100Ω differential termination
20	0-1	V _{cc}	Input	3.135 to 3.465VDC

Center slug is connected to Signal Ground, all other pins are N/C, TX_Dis functions: Logic 1: Disable Optical Output, Logic 0: Enable Optical Output

Dual Port Lightning Series MIL-DTL-38999 Optical Transceiver,
GbE, 1x/2xFC or Serial FPDP Applications, Multimode, 850nm VCSELs
APPLICATION SCHEMATIC

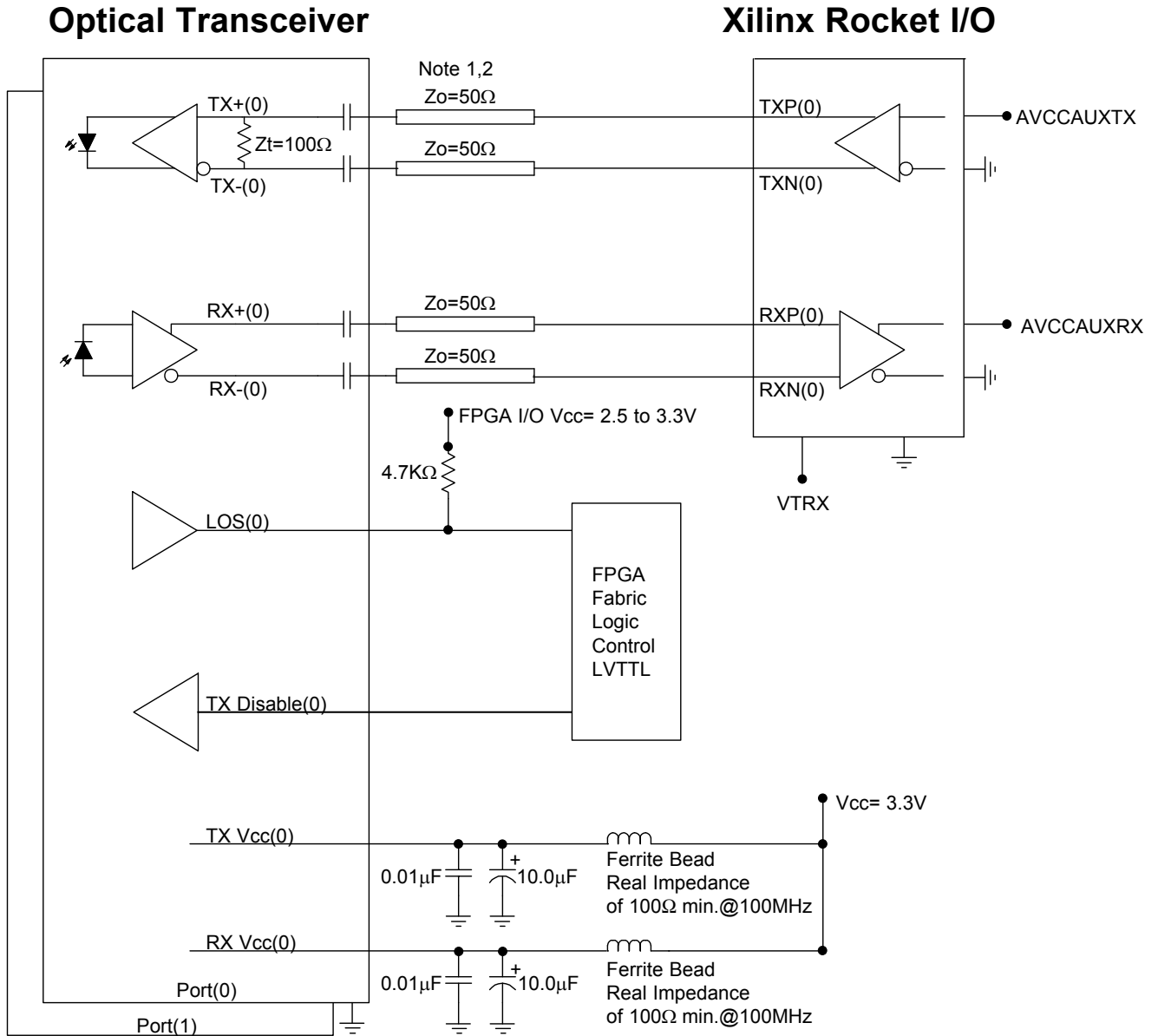

Typical application schematic shown
For alternate applications or termination
techniques, please consult the Factory

Note: 1
When using controlled impedance cable
(Coaxial cable) and Pre_Emphasis,
lengths of 1.0meter are obtainable.

Note: 2
50 Ohm impedance termination shown.
For alternate impedance requirements,
please consult the Factory.

Dual Port Lightning Series MIL-DTL-38999 Optical Transceiver,
GbE, 1x/2xFC or Serial FPDP Applications, Multimode, 850nm VCSELs

APPENDIX A1

MIL-DTL-38999 FIBER OPTIC CABLE PLUG / MIL-T-29504 PIN TERMINI

*See DSCC or SAE QPL for Approved Suppliers

<http://www.dscclia.mil/programs/qmlqpl/QPLdetail.asp?QPL=38999>

*D38999 PLUG - PIN INSERT

MIL-DTL-38999 CABLE PLUG

MS PLUG P/N

*D38999/26WF11PN

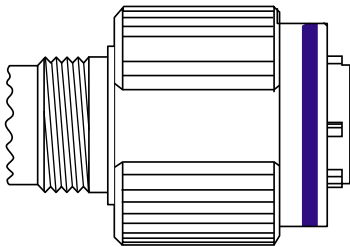

*FIBER OPTIC PIN TERMINUS

MIL-T-29504 PIN TERMINUS

MS PIN TERMINUS P/N

*M29504/04-xxxx**

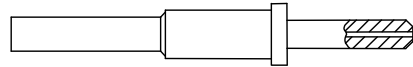

**defined by fiber optic cable configuration

*CABLE PROTECTION CAP

D38999/32 PLUG PROTECTION CAP

MS PLUG CAP P/N

*D38999/32W19N

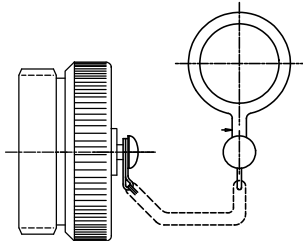

*CABLE BACKSHELL

MIL-C-85049 CABLE BACKSHELL

MS BACKSHELL P/N

*MS85049/xxxxxx**

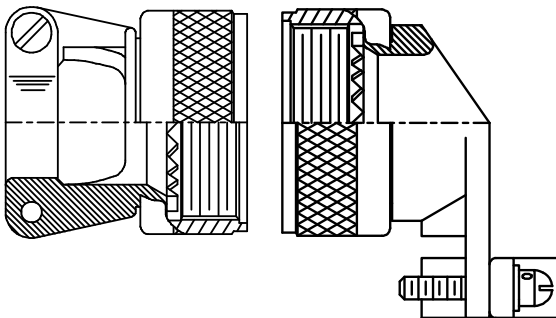

**Straight or angled backshell - defined by application / mounting configuration

D38999 PLUG PORT FUNCTIONS

PORT NUMBER	TX	RX
4	H	F
5	B	D

TOP
Optical Cable Plug Interface

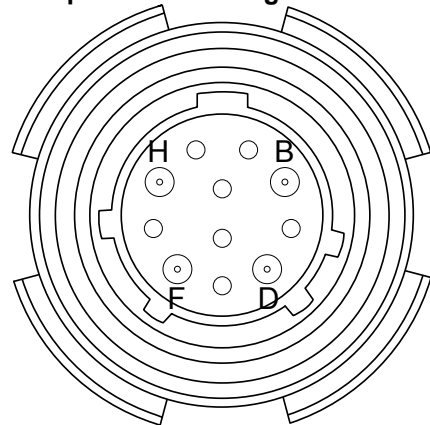

Front face of the optical cable plug pin insert shown. Transceiver insert opposite.

Pin Termini

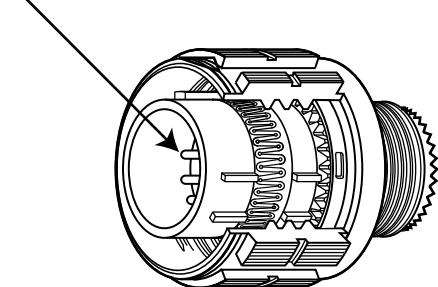

Dual Port Lightning Series MIL-DTL-38999 Optical Transceiver,
GbE, 1x/2xFC or Serial FPDP Applications, Multimode, 850nm VCSELs

APPENDIX A2

PART NUMBER OPTIONS

Dual Port, Square Flange, VCSEL

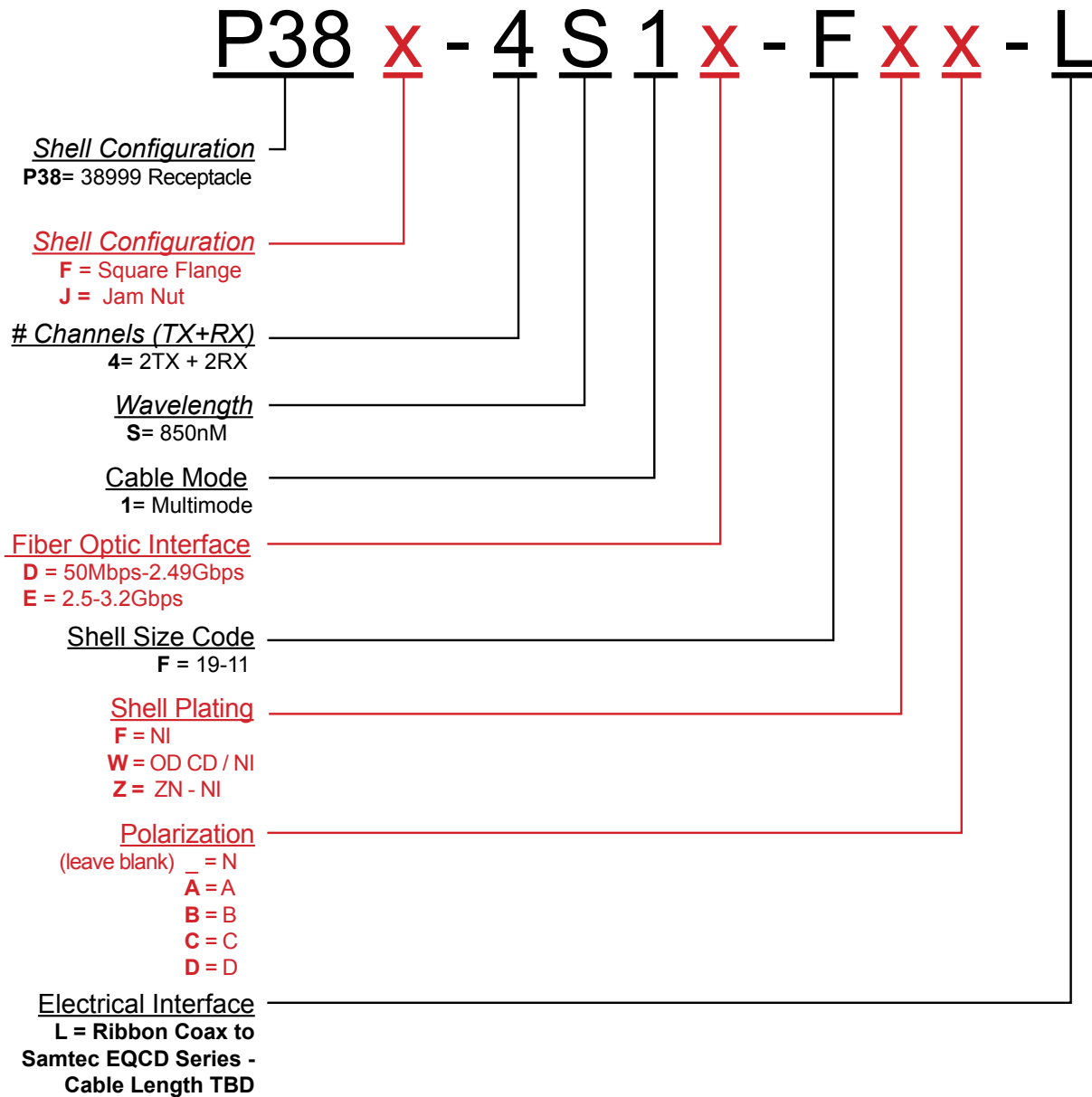

Other wavelength, mounting and port count options are available.
Please consult the Protokraft website for alternate configurations.



192 Bob Fitz Road, Johnson City, TN 37615
salesmp@moog.com
moogprotokraft.com