

LIGHTNING SERIES

MIL-DTL-38999 OPTICAL TRANSCEIVER, FC, ETHERNET AND sFPDP APPLICATIONS, MULTIMODE, 850 NM VCSELs

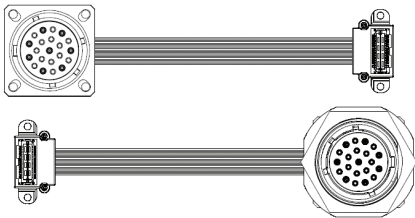

Lightning series optical fiber transceivers consist of optoelectronic transmitter and receiver functions integrated into a bulkhead mounted MIL-DTL-38999, Series III receptacle connector. The optical transmitters are 850 nm VCSEL lasers. The transmitter input lines are driven with differential CML signals applied to the transmitter (TX+ and TX-) lines. Dual loop, temperature compensated, VCSEL drivers convert the transmitter input signals to suitable VCSEL bias and modulation currents.

The optical receivers consist of PIN and preamplifier assemblies and limiting post-amplifiers. Outputs from the receivers consist of differential CML data signals on the receiver (RX+ and RX-) lines and single ended CMOS indicator functions on the Loss of Signal (LOS) lines. The receiver data lines are squelched upon LOS assertion, preventing errant data generation when an invalid incoming optical signal is presented to the transceiver.

The electrical interface to the Lightning series optical transceivers is a ribbon coax to Samtec EQCD high density cable assembly enabling SMT interconnection to a customer's backplane, motherboard or daughtercard.

Lightning series optical fiber transceivers are vibration isolated, environmentally hardened components designed for use in harsh environment applications.

LIGHTNING SERIES MIL-DTL-38999 OPTICAL TRANSCEIVER, FC, ETHERNET, AND sFPDP APPLICATIONS, MULTIMODE, 850 NM VCSELs

Four TX and Four RX Channels Operating from 50 Mbps to 3.2 Gbps

FEATURES

- Suitable for Gigabit Ethernet, 1x / 2x Fibre Channel, ARINC 818 and sFPDP applications from 50 Mbps to 3.2 Gbps
- Optical fiber link distances up to 550 meters (50 / 125µ 500 MHz*Km MMF)
- Maximum optical channel bit error rate less than 1×10^{-12}
- Operating temperature range from -40° to +85° C
- Shock, vibration and immersion resistant per MIL-STD-810
- Olive drab cadmium over electroless nickel plating meets stringent corrosion resistance specifications
- Aluminum alloy MIL-DTL-38999 housings are strong, durable, and lightweight
- MIL-T-29504 compliant optical fiber connector interface
- Samtec EQCD Series electrical connector for SMT interface

APPLICATIONS

Lightning series bulkhead mounted optical transceivers enable high speed network communications over long distances in harsh environments.

- Fast or Gigabit Ethernet switches and peripherals
- Fibre Channel switches and peripherals
- sFPDP data links
- ARINC 818 video displays and drivers

The MIL-DTL-38999, series III shell provides a sealed optical interface that is water-tight to MIL-STD-810 / IP67 / NEMA-4x when mated.

The multimode optical fiber interface supports applications where copper cable link distance, bandwidth, weight or bulk make the use of twisted pair, twinax or quadax copper conductors unacceptable.

ORDERING INFORMATION

Application	Part Number
GbE, 1x/2xFC, Flange	P38F-8S1D-HW-Lxxx
sFPDP / ARINC 818, Flange	P38F-8S1E-HW-Lxxx
GbE, 1x/2xFC, Jam Nut	P38J-8S1D-HW-Lxxx
sFPDP / ARINC 818, Jam Nut	P38J-8R1E-HW-Lxxx

See page 7 for standard part number / cable length options.

LIGHTNING SERIES MIL-DTL-38999 OPTICAL TRANSCEIVER, FC, ETHERNET, AND sFPDP APPLICATIONS, MULTIMODE, 850 NM VCSELs

ABSOLUTE MAXIMUM RATINGS

Absolute maximum limits mean that no catastrophic damage will occur if the product is subjected to these ratings for short periods, provided each limiting parameter is in isolation and all other parameters have values within the performance specification. It should not be assumed that limiting values of more than one parameter can be applied to the product at the same time.

Parameter	Symbol	Minimum	Typical	Maximum	Unit
Storage Temperature	T_S	-55		+100	°C
Supply Voltage	V_{CC}	-0.5		+4.5	V
TX_DIS Input Voltage	V_I	-0.5		$V_{CC} + 0.5$	V
Differential Input Voltage (p-p)	V_D			2.2	V
RX Output Current	I_P			50	mA

RECOMMENDED OPERATING CONDITIONS

Parameter	Symbol	Minimum	Typical	Maximum	Unit
Operating Temperature	T_A	-40		+85	°C
Power Supply Voltage	V_{CC}	+3.135		+3.465	V
TX Common Mode Voltage	V_{CM}		2.0		V
TX Differential Input Voltage (p-p)	V_D	0.25		2.2	V
Power Supply Noise (p-p)	N_P			200	mV

SPECIFICATIONS COMPLIANCE

Requirement	Feature	Condition	Notes
MIL-STD-883	ESD	Class II	2200 V
MIL-STD-810	Vibration	3.8g ² / Hz	43 G rms
MIL-STD-810	Shock	40.0 g	6-9 mS
MIL-STD-810	Immersion	1.0 Meter	2.0 Hours
MIL-STD-1344	Flame Resistance	Method 1012	30 Seconds
MIL-STD-1344	Damp Heat	10 Cycles	24 Hours
MIL-STD-38999	Mating Durability	500 Cycles	<0.5 dB Change
FDA / CDRH / IEC-825-1	Eye Safety	Class 1	No Safety Interlocks Required

MATERIALS

Item	Detail	Notes
Shell	Aluminum Alloy	
Shell Plating	Olive Drap Cadmium Over Nickel	QQ-P-416, QQ-N-290
Insert	Thermoplastic	
Interfacial Seal	Elastomer	
Alignment Sleeves	Composite Polymer	
Printed Circuits	Polyimide / FR-4	Mil-P-31032 Type 4

LIGHTNING SERIES MIL-DTL-38999 OPTICAL TRANSCEIVER, FC, ETHERNET, AND sFPDP APPLICATIONS, MULTIMODE, 850 NM VCSELs

OPTICAL TRANSMITTERS T_A = OPERATING TEMPERATURE RANGE, $V_{CC} = 3.135\text{ V TO }3.465\text{ V}$

Parameter	Symbol	Minimum	Typical	Maximum	Unit
Optical Output Power (BER<10 ⁻¹²)	P_o	-9.5		-4.0	dBm
Optical Output Wavelength	λ_{OUT}	830	850	860	nM
Spectral Width	$\Delta\lambda_{RMS}$			0.85	nM
Extinction Ratio	ER	6.0			dB
Optical Rise, Fall Time (20% to 80%)	$t_{R,F}$			150	pS

OPTICAL RECEIVERS T_A = OPERATING TEMPERATURE RANGE, $V_{CC} = 3.135\text{ V TO }3.465\text{ V}$

Parameter	Symbol	Minimum	Typical	Maximum	Unit
Optical Sensitivity (BER<10 ⁻¹² , ER=9.0)	P_I				dBm
P38x-xxxD-xx @ 125 Mbps to 1.25 Gbps		-17.0		0.0	
P38x-xxxD-xx @ 2.125 Gbps		-15.0			
P38x-xxxE-xx @ 2.5 Gbps to 3.2 Gbps		-14.0			
Optical Output Wavelength	λ_{IN}	830		860	nM
RX Data Output - Low	$V_{OL} - V_{CC}$	-1.810		-1.475	V
RX Data Output - High	$V_{OH} - V_{CC}$	-1.165		-0.880	V

POWER SUPPLY CURRENT T_A = OPERATING TEMPERATURE RANGE, $V_{CC} = 3.135\text{ V TO }3.465\text{ V}$

Parameter	Symbol	Minimum	Typical	Maximum	Unit
Supply Current per Port	I_{CCT}		100	140	mA

OPTICAL LINK DISTANCES

Protocol	62.5 / 125 μ 200 MHz*Km	50 / 125 μ 500 MHz*Km
2xFibre Channel - ANSI X3.297 FC-PI	150 M	300 M
Gigabit Ethernet - IEEE-802.3:2005	275 M	550 M
1xFibre Channel - ANSI X3.297 FC-PH-2	300 M	500 M

LIGHTNING SERIES MIL-DTL-38999 OPTICAL TRANSCEIVER, FC, ETHERNET, AND sFPDP APPLICATIONS, MULTIMODE, 850 NM VCSELs

OUTLINE DRAWING

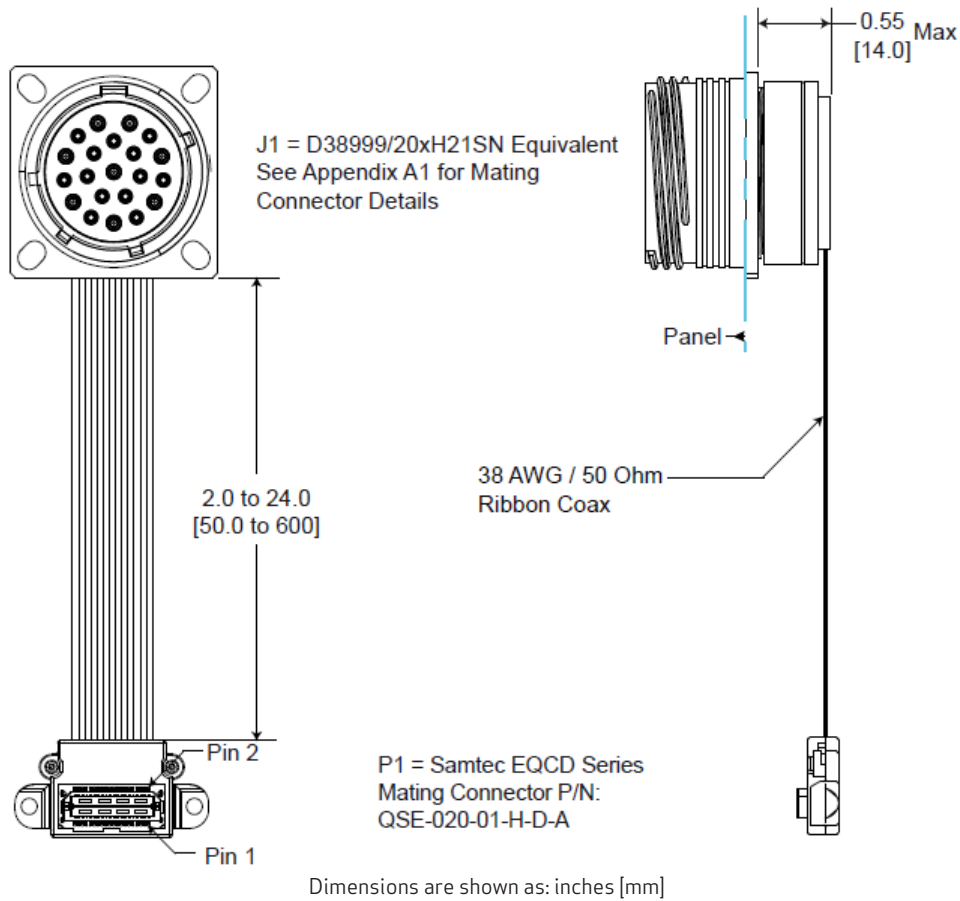

PANEL CUTOUT DIMENSIONS

Shell Size Code	Shell Size	M Min.	P Holes	R Bsc
H	23	1.547 [39.29]	0.159 [4.0] / 0.149 [3.8]	1.375 [34.9]

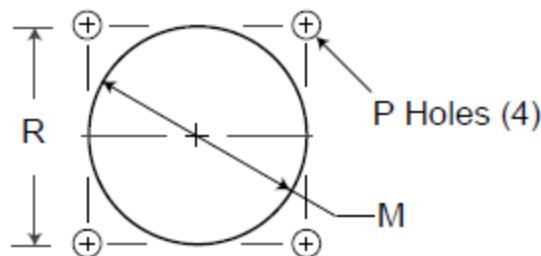

Part Number = P38F-xxxx-Hx-Lxxx

*See page 7 for part number / cable length options and page 13 for complete ordering options.

LIGHTNING SERIES MIL-DTL-38999 OPTICAL TRANSCEIVER, FC, ETHERNET, AND sFPDP APPLICATIONS, MULTIMODE, 850 NM VCSELs

OUTLINE DRAWING

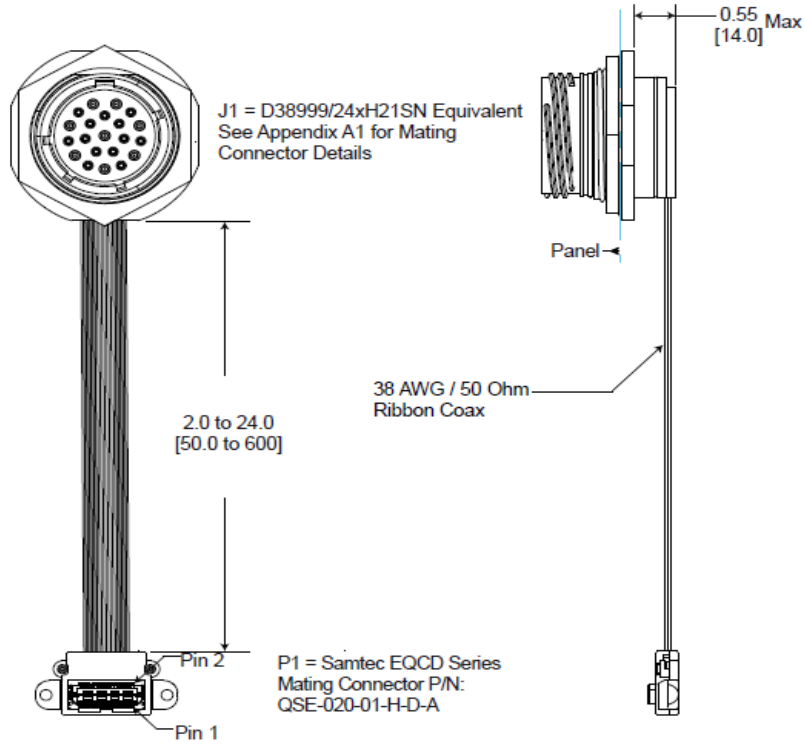

Dimensions are shown as: inches [mm]

PANEL CUTOUT DIMENSIONS

Shell Size Code	Shell Size	D1 Min.	D2 Min.
H	23	1.635 [41.53]	1.585 [40.26]

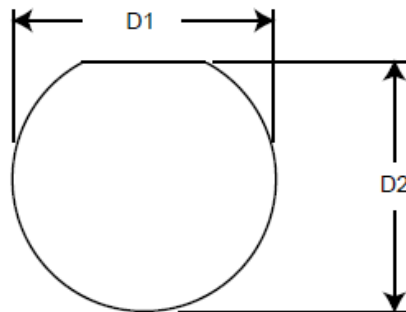

Part Number = P38J-xxxx-Hx-Lxxx

*See page 7 for part number / cable length options and page 13 for complete ordering options.

LIGHTNING SERIES MIL-DTL-38999 OPTICAL TRANSCEIVER, FC, ETHERNET, AND sFPDP APPLICATIONS, MULTIMODE, 850 NM VCSELs

OUTLINE DRAWING

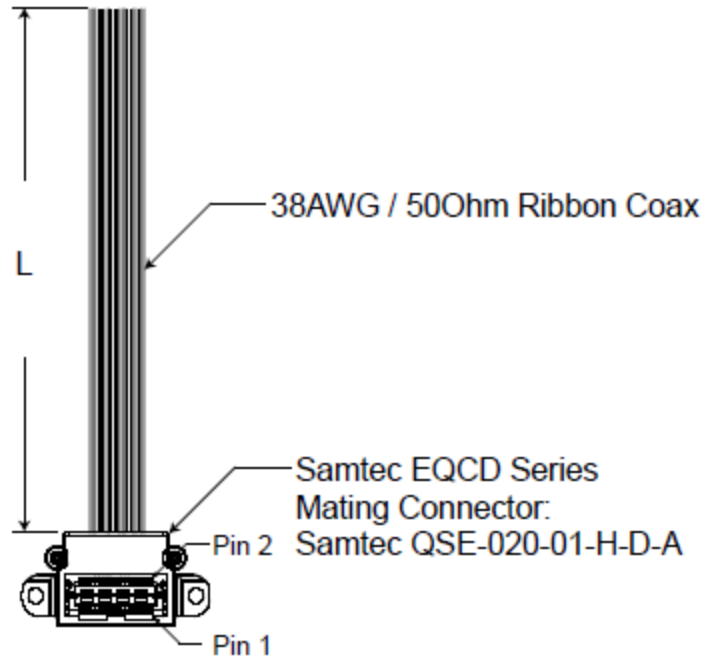

RIBBON COAX CABLE LENGTH OPTIONS

L(mm) +/-6.0	Item Number
50	xxxx-xxxx-xx-L050
100	xxxx-xxxx-xx-L100
150	xxxx-xxxx-xx-L150
200	xxxx-xxxx-xx-L200
250	xxxx-xxxx-xx-L250

LIGHTNING SERIES MIL-DTL-38999 OPTICAL TRANSCEIVER, FC, ETHERNET, AND sFPDP APPLICATIONS, MULTIMODE, 850 NM VCSELs

J1 D38999 PIN AND PORT ASSIGNMENTS

Top Optical Interface

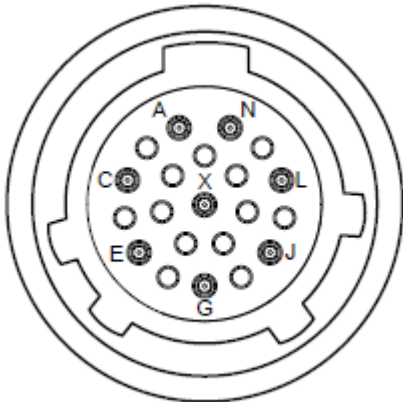

Front view of the D38999 optical insert shown, fiber optic cable plug opposite - see Appendix A1 for details.

MIL-DTL-38999 OPTICAL INTERFACE

Port Number	TX	RX
0	J	L
1	N	G
2	X	A
3	E	C

LIGHTNING SERIES MIL-DTL-38999 OPTICAL TRANSCEIVER, FC, ETHERNET, AND sFPDP APPLICATIONS, MULTIMODE, 850 NM VCSELs

PRINTED CIRCUIT BOARD FOOTPRINT

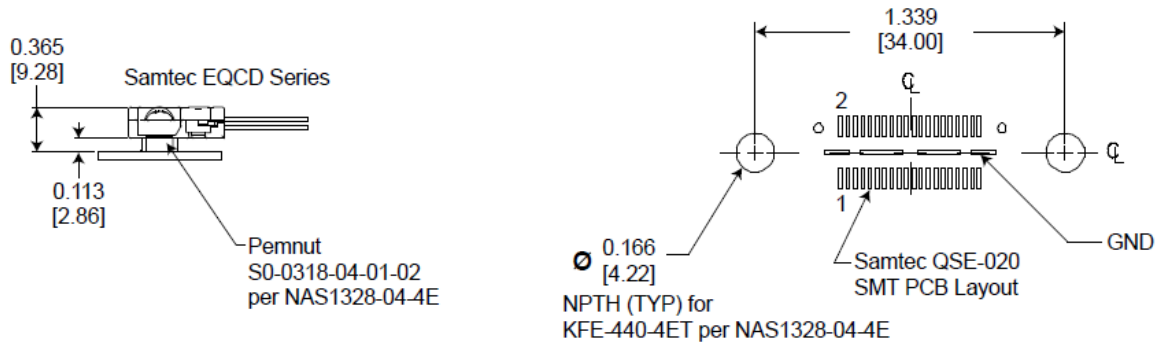

Dimensions are shown as: inches [mm]

ELECTRICAL			PORT NUMBER	OPTICAL	
Pin Number	Function	Logic Family		Pin Number	Function
1	LOS	Open Drain CMOS	0	L	RX
2	GND	NA	0-3	ALL	NA
3	RX-	CML	0	L	RX
4	NC	NA	NA	NA	NA
5	RX+	CML	0	L	RX
6	TX_Dis	CMOS	0	J	TX
7	TX-	CML	0	J	TX
8	V _{cc}	NA	0-3	ALL	NA
9	TX+	CML	0	J	TX
10	V _{cc}	NA	0-3	ALL	NA
11	LOS	Open Drain CMOS	1	G	RX
12	GND	NA	0-3	ALL	NA
13	RX-	CML	1	G	RX
14	NC	NA	NA	NA	NA
15	RX+	CML	1	G	RX
16	TX_Dis	CMOS	1	N	TX
17	TX-	CML	1	N	TX
18	V _{cc}	NA	0-3	ALL	NA
19	TX+	CML	1	N	TX
20	V _{cc}	NA	0-3	ALL	NA

Center slug is Ground.

TX_Dis functions: Logic 1: Disable Optical Output, Logic 0: Enable Optical Output.

For All Loss of Signal (LOS) Functions: Satisfactory Optical Input: Logic "0" Output / Unsatisfactory Optical Input: Logic "1" Output.

For All Transmitter Disable (TX Dis) Functions: Logic 1 Input: Disable Optical Output / Logic 0 Input: Enable Optical Output.

The TX_Dis functions have internal 4.7KΩ to 10.0KΩ pullups.

All CML functions are internally AC coupled with 100Ω differential terminations.

LIGHTNING SERIES MIL-DTL-38999 OPTICAL TRANSCEIVER, FC, ETHERNET, AND sFPDP APPLICATIONS, MULTIMODE, 850 NM VCSELs

PRINTED CIRCUIT BOARD FOOTPRINT

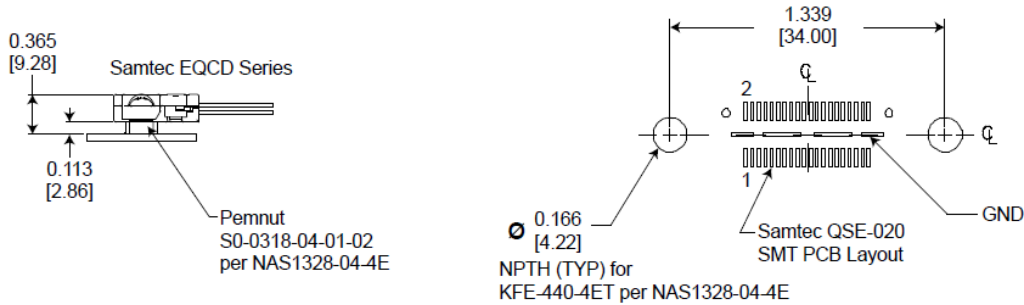

Dimensions are shown as: inches [mm]

ELECTRICAL			PORT NUMBER		OPTICAL	
Pin Number	Function	Logic Family		Pin Number	Function	
21	LOS	Open Drain CMOS	2	A	RX	
22	GND	NA	0-3	ALL	ALL	
23	RX-	CML	2	A	RX	
24	NC	NA	NA	NA	NA	
25	RX+	CML	2	A	RX	
26	TX_Dis	CMOS	2	X	TX	
27	TX-	CML	2	X	TX	
28	V _{cc}	NA	0-3	ALL	ALL	
29	TX+	CML	2	X	TX	
30	V _{cc}	NA	0-3	ALL	ALL	
31	LOS	Open Drain CMOS	3	C	RX	
32	GND	NA	0-3	ALL	ALL	
33	RX-	CML	3	C	RX	
34	NC	NA	NA	NA	NA	
35	RX+	CML	3	C	RX	
36	TX_Dis	CMOS	3	E	TX	
37	TX-	CML	3	E	TX	
38	V _{cc}	NA	0-3	ALL	ALL	
39	TX+	CML	3	E	TX	
40	V _{cc}	NA	0-3	ALL	ALL	

Center slug is Ground.

TX_Dis functions: Logic 1: Disable Optical Output, Logic 0: Enable Optical Output.

For All Loss of Signal (LOS) Functions: Satisfactory Optical Input: Logic "0" Output / Unsatisfactory Optical Input: Logic "1" Output.

For All Transmitter Disable (TX Dis) Functions: Logic 1 Input: Disable Optical Output / Logic 0 Input: Enable Optical Output.

The TX_Dis functions have internal 4.7KΩ to 10.0KΩ pullups.

All CML functions are internally AC coupled with 100Ω differential terminations.

LIGHTNING SERIES MIL-DTL-38999 OPTICAL TRANSCEIVER, FC, ETHERNET, AND sFPDP APPLICATIONS, MULTIMODE, 850 NM VCSELs

APPLICATION SCHEMATIC

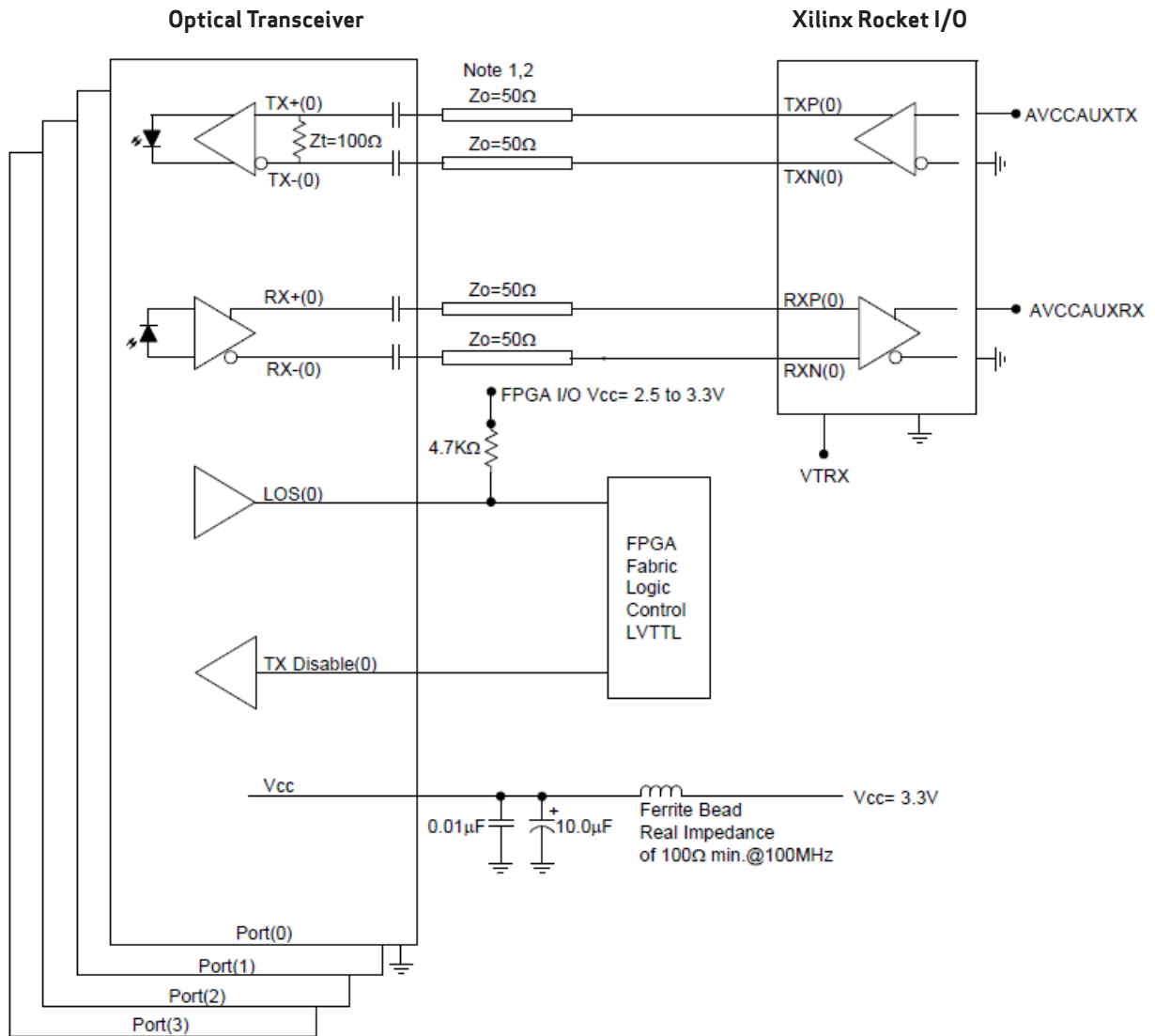

Typical application schematic shown. For alternate applications or termination techniques, please consult the factory.

Notes:

1. When using controlled impedance cable (Coaxial cable) and Pre_Emphasis, lengths of 1.0 meter are obtainable.
2. 50 ohm impedance termination shown. For other impedance requirements please consult the factory.

LIGHTNING SERIES MIL-DTL-38999 OPTICAL TRANSCEIVER, FC, ETHERNET, AND sFPDP APPLICATIONS, MULTIMODE, 850 NM VCSELs

APPENDIX A1

MIL-DTL-38999 FIBER OPTIC CABLE PLUG / MIL-T-29504 PIN TERMINI
 *See DSCC or SAE QPL for Approved Suppliers
<http://www.dsccl.dla.mil/programs/qmlqpl/QPLdetail.asp?QPL=38999>

*D38999 PLUG - PIN INSERT MIL-DTL-38999 CABLE PLUG

MS Plug P/N *D38999 / 26MH21PN

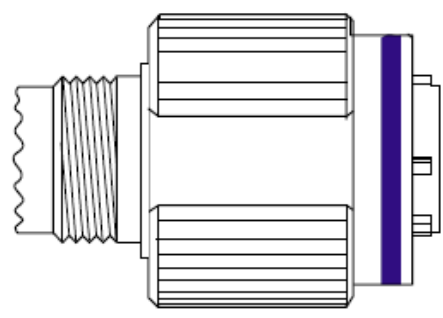

*FIBER OPTIC PIN TERMINUS MIL-T-29504 PIN TERMINUS

MS Pin Terminus P/N *M29504 / 04-XXX**

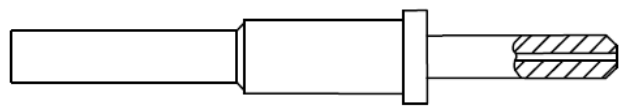

**Defined by fiber optic cable configuration

*CABLE PROTECTION CAP D38999 / 32 PLUG PROTECTION CAP

MS Plug Cap P/N *D38999 / 32W23N

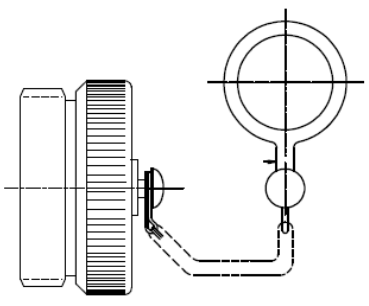

D38999 PLUG PORT FUNCTIONS

Port	TX	RX
0	J	L
1	N	G
2	X	A
3	E	C

TOP
Optical Cable Plug Interface

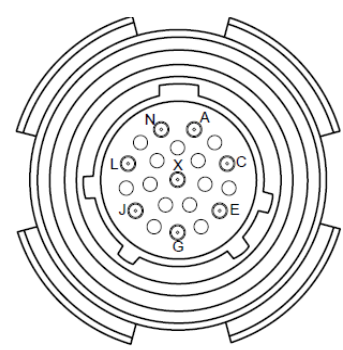

Front face of the optical cable plug pin insert shown. Transceiver insert opposite.

*CABLE BACKSHELL MIL-C-85049 CABLE BACKSHELL

MS Backshell P/N *MS85049 / XXXXXX**

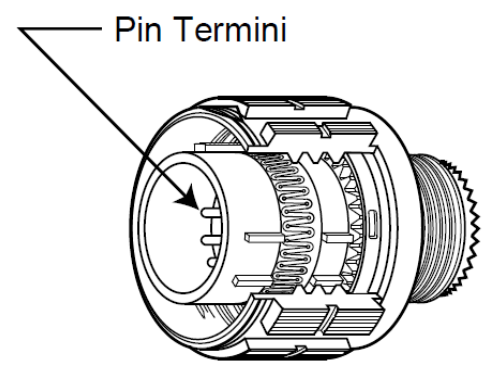
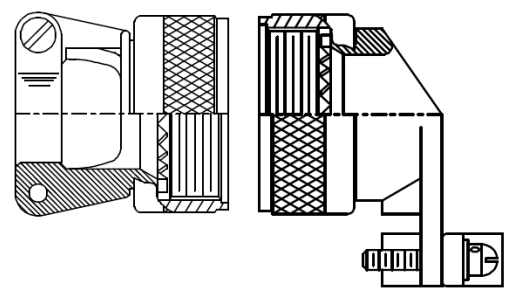

**Straight or angled backshell - defined by application / mounting configuration

LIGHTNING SERIES MIL-DTL-38999 OPTICAL TRANSCEIVER, FC, ETHERNET, AND sFPDP APPLICATIONS, MULTIMODE, 850 NM VCSELs

APPENDIX A2 PART NUMBER OPTIONS

QUAD PORT, SQUARE FLANGE, VCSEL

P38 **x** - **8** **S** **1** **x** - **H** **x** **x** - **L**

SHELL CONFIGURATION

P38 = 38999 Receptacle

SHELL CONFIGURATION

F = Square Flange

J = Jam Nut

CHANNELS (TX+RX)

8 = 4TX + 4RX

WAVELENGTH

S = 850 nM

CABLE MODE

1 = Multimode

FIBER OPTIC INTERFACE

D = 50 Mbps - 2.49 Gbps

E = 2.5 Gbps - 3.20 Gbps

SHELL SIZE CODE

H = 23 - 21

SHELL PLATING

F = NI

W = OD CD / NI

Z = ZN - NI

POLARIZATION

(Leave blank) = N

A = A

B = B

C = C

D = D

ELECTRICAL INTERFACE

L = Ribbon Coax to

Samtec EQCD Series

- Cable Length TBD

Other wavelength, mounting and port count options are available. Please consult the Protokraft website for alternate configurations.



192 Bob Fitz Road, Johnson City, TN 37615
 salesmp@moog.com
 moogprotokraft.com

Products and solutions are subject to the export control requirements of the country in which they are manufactured and/or sold.

© 2020 Moog, Inc. All rights reserved. Product and company names listed are trademarks or trade names of their respective companies.