

# Magnum Series EMI Hardened

Size 8 Cavity Optoelectronic PCB  
Insert, \*ELIO<sup>®</sup>, Front Release, 850nm  
- Arinc 818, 803 & 804 Compliant

Optical Transmitter Unit

## FEATURES

- Compliant with Arinc 664, 818, 803 & 804
- Suitable for Fast Ethernet, Gigabit Ethernet, 1x/2x/4xFibre Channel and sFPDP applications from 50Mbps to 4.25Gbps
- Maximum optical channel bit error rate less than  $1 \times 10^{-12}$
- Operating temperature range from -40°C to +85°C
- Shock and vibration resistant per RTCA / D0-160E
- Arcap contact insert material meets stringent EMI / RFI / ESD & EMP performance specifications
- Six pin PCB footprint with TX\_Fault and TX\_Dis functions
- ELIO<sup>®</sup> 2.5mm ceramic optical fiber ferrule connector interface per EN 4531\*
- Compatible with Arinc 600 and MIL-DTL-83527 size 8 (Quadrax) insert cavities

## APPLICATIONS

Magnum series printed circuit board mounted optical transmitters enable high speed network communications over long distances in harsh environments.

- Fast or Gigabit Ethernet switches and peripherals
- Fibre Channel switches and peripherals
- Serial Rapid I/O (sRIO) interfaces
- PCI - Express Links
- sFPDP data links
- Video displays

This size 8 Optoelectronic cavity insert provides a rugged optical interface that is compliant with ELIO<sup>®</sup> 2.5mm ceramic optical ferrules\*.

The multimode optical fiber interface supports applications where copper cable link distance, bandwidth, weight or bulk make the use of twisted pair, twinax or quadrax copper conductors unacceptable.

\*ELIO<sup>®</sup> is a registered trademark of Esterline Souriau

US Pat. # 7,690,849



One TX Channel Operating from 50Mbps to 4.25Gbps

## DESCRIPTION

Magnum series Optoelectronic size 8 cavity PCB insert transmitters consist of optoelectronic transmitter functions integrated into a printed circuit board mounted pin contact. The optical transmitters are 850nm VCSEL lasers. The transmitter input lines are driven with differential CML signals applied to the transmitter (TX+ and TX-) lines. Dual loop, temperature compensated, VCSEL drivers convert the transmitter input signals to suitable VCSEL bias and modulation currents. The TX\_Fault circuit disables the optical transmitter output when the optical output power or internal current exceeds predefined limits. The fault condition is latched until reset by a toggle of TX\_Dis or VCC. A CMOS fault signal is generated on the TX\_Fault line upon a transmitter optical or electrical fault condition.

The optical mating interface to the Magnum series size 8 cavity insert optical transmitters is an ELIO<sup>®</sup> 2.5mm ceramic fiber optic ferrule stub per EN 4531. The ferrule stub has an integral 50/125µ multimode optical fiber enabling it to interface to either 62.5/125µ or 50/125µ optical fiber cable.

The electrical interface to the Magnum series size 8 cavity insert optical transmitters is a six position pin header suitable for thru-hole soldering to a flexible or rigid printed circuit.

Magnum series size 8 cavity insert optical transmitters are vibration isolated, environmentally hardened components designed for use in harsh environment applications.

## ORDERING INFORMATION

Application	Part Number
50Mbps to 3.19Gbps	P44F-TS1E-EK-EMI
3.2Gbps to 4.25Gbps	P44F-TS1G-EK-EMI

Magnum Series, 2.5mm Ferrule, Size 8 Cavity Insert, Optical Transmitter,  
Multimode, 850nm, Compliant with ARINC 664, 818, 803 & 804

### ABSOLUTE MAXIMUM RATINGS

Absolute maximum limits mean that no catastrophic damage will occur if the product is subjected to these ratings for short periods, provided each limiting parameter is in isolation and all other parameters have values within the performance specification. It should not be assumed that limiting values of more than one parameter can be applied to the product at the same time.

Parameter	Symbol	Minimum	Typical	Maximum	Unit
Storage Temperature	$T_s$	-55		+100	°C
Supply Voltage	$V_{CC}$	-0.5		+4.5	V
TX_DIS Input Voltage	$V_i$	-0.5		$V_{CC} + 0.5$	V
Differential Input Voltage (p-p)	$V_D$			2.2	V

### RECOMMENDED OPERATING CONDITIONS

Parameter	Symbol	Minimum	Typical	Maximum	Unit
Operating Temperature	$T_A$	-40		+85	°C
Power Supply Voltage	$V_{CC}$	+3.135		+3.465	V
TX Differential Input Voltage (p-p)	$V_D$	0.25		2.2	V
Power Supply Noise (p-p)	$N_P$			200	mV

### ENVIRONMENTAL OPERATING CONDITIONS

Requirement	Feature	Condition	Notes
RTCA / D0-160E	ESD	HBM	2200V
RTCA / D0-160E	Vibration	3.8g <sup>2</sup> /Hz	43G rms
RTCA / D0-160E	Shock	40.0g	6-9mS
RTCA / D0-160E	Flame Resistance		30 Seconds
RTCA / D0-160E	Damp Heat	10 Cycles	24 Hours
ARINC 801	Mating Durability	500 Cycles	<0.5dB Change
FDA / CDRH / IEC-825-1	Eye Safety	Class 1	No Safety Interlocks Required

### MATERIALS

Item	Detail	Notes
Insert Shell	Arcap	
Solder Pins	Brass	
Solder Pin Plating	Gold over Nickel	
Ferrule	Ceramic	
Printed Circuits	Polyimide / FR-4	

Magnum Series, 2.5mm Ferrule, Size 8 Cavity Insert, Optical Transmitter,  
Multimode, 850nm, Compliant with ARINC 664, 818, 803 & 804

**OPTICAL TRANSMITTERS  $T_A$  = Operating Temperature Range,  $V_{CC}$  = 3.135V to 3.465V**

Parameter	Symbol	Minimum	Typical	Maximum	Unit
Optical Output Power (BER<math>10^{-12}</math>)	$P_o$	-6.5		-1.0	dBm
Optical Output Wavelength	$\lambda_{OUT}$	830	850	860	nM
Spectral Width	$\Delta\lambda_{RMS}$			0.85	nM
Extinction Ratio	ER				dB
xxxx-xx1E-xx @ 50Mbps to 1.25Gbps		9.0			
xxxx-xx1E-xx @ 2.125Gbps		9.0			
xxxx-xx1E-xx @ 2.5Gbps to 3.19Gbps		6.0			
xxxx-xx1G-xx @ 3.2Gbps to 4.25Gbps		5.0			

**POWER SUPPLY CURRENT  $T_A$  = Operating Temperature Range,  $V_{CC}$  = 3.135V to 3.465V**

Parameter	Symbol	Minimum	Typical	Maximum	Unit
Supply Current per transmitter	$I_{CCT}$		80	110	mA

Magnum Series, 2.5mm Ferrule, Size 8 Cavity Insert, Optical Transmitter,  
Multimode, 850nm, Compliant with ARINC 664, 818, 803 & 804

### OUTLINE DRAWING

Dimensions are shown as: inches (mm)

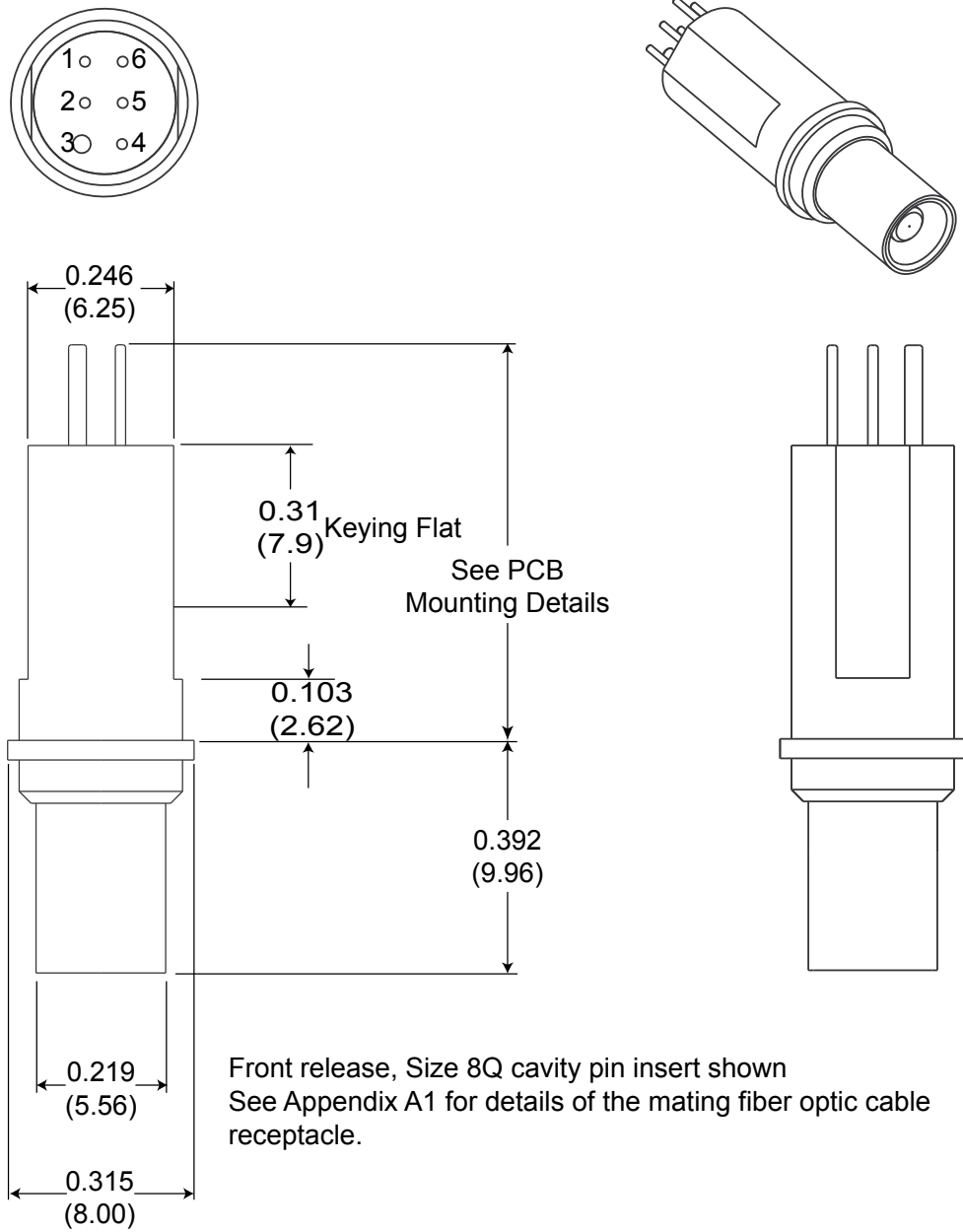

Magnum Series, 2.5mm Ferrule, Size 8 Cavity Insert, Optical Transmitter,  
Multimode, 850nm, Compliant with ARINC 664, 818, 803 & 804

### ELECTRICAL PIN ASSIGNMENTS

Pin Number	Symbol	Description	Logic Family
1	TX_DIS	Transmit Disable - Input Logic 1: Disable Optical Output Logic 0: Enable Optical Output	CMOS Internal 4.7KΩ pulldown
2	V <sub>cc</sub>	Power Supply	N/A
3	GND	Ground	N/A
4	TX_Fault	Internal TX Fault Indicator - Output Satisfactory Operation: Logic "0" Output Internal Fault: Logic "1" Output	Open Drain CMOS
5	TX-	Transmitter Data Input	CML
6	TX+	Transmitter Data Input	CML

### PRINTED CIRCUIT BOARD FOOTPRINT

Dimensions are shown as: inches

#### PCB Hole Pattern Mounting Side View

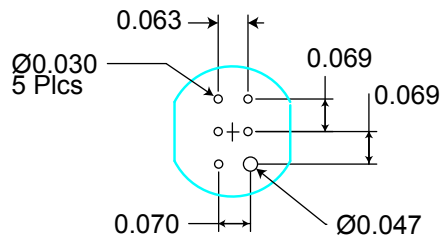

Magnum Series, 2.5mm Ferrule, Size 8 Cavity Insert, Optical Transmitter,  
Multimode, 850nm, Compliant with ARINC 664, 818, 803 & 804

### PCB MOUNTING DETAILS

Dimensions are shown as: inches [mm]

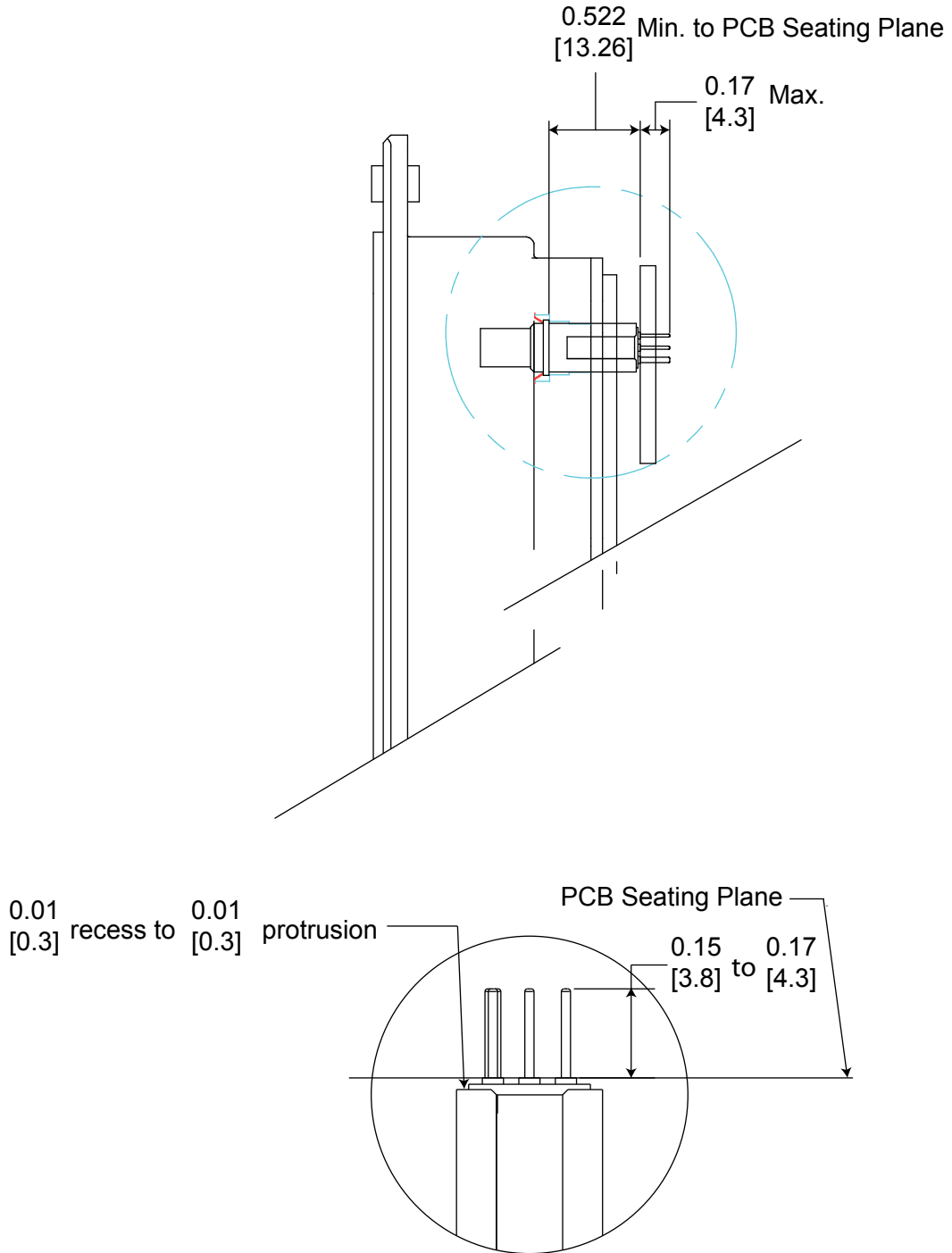

## APPLICATION SCHEMATIC For Xilinx Rocket I/O Interfaces

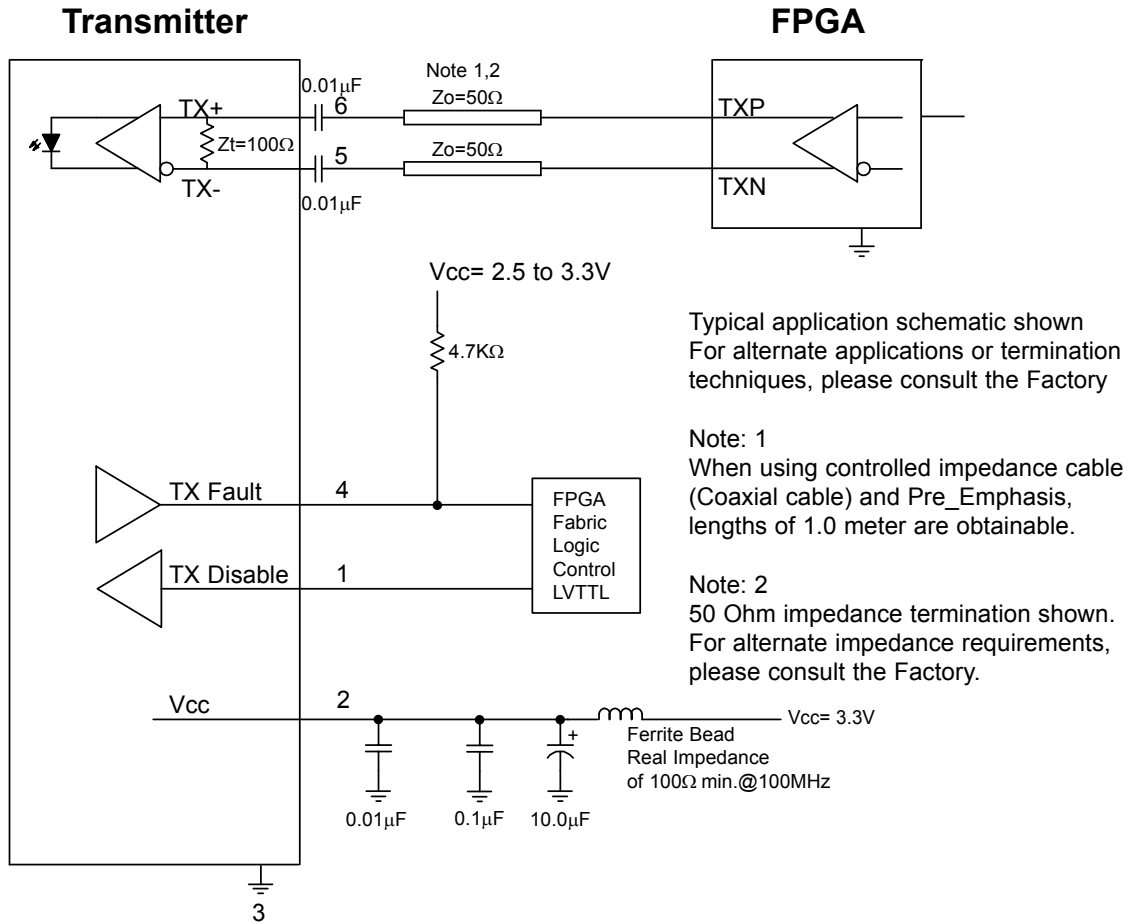

Magnum Series, 2.5mm Ferrule, Size 8 Cavity Insert, Optical Receiver,  
Multimode, 850nm, Arinc 664, 818, 803 & 804 Compliant

## APPENDIX A1

### SOURIAU ELIO® FIBER OPTIC CABLE ADAPTERS



**ELIO® 8 Adapter for Quadrax # 8 Cavity in Female Inserts**  
**Ordering Information: ELIO AQ0S**

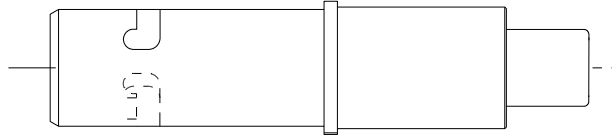
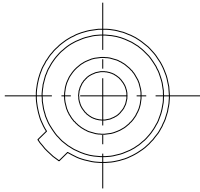

**ELIO® multimode contact**  
**Ordering information**

ELIO	09N	G	L	A
<b>Cable external diameter &amp; Contact sealing:</b>				
09N: 0.9 <sup>+0.1</sup> mm. Non waterproof				
18N: from 1.5mm to 1.9mm. Non waterproof				
18W: 1.8 <sup>+0.1</sup> mm. Waterproof				
20N: from 1.7mm to 2.1mm. Non waterproof				
20W: 2.0 <sup>+0.1</sup> mm. Waterproof				
<b>Fibre type:</b>				
G: ELIO® Multimode				
<b>Boot type:</b>				
L: Long boot				
S: Short boot				
N: No boot (non waterproof version only)				
<b>Contact version index</b>				



**MOOG**  
**PROTOKRAFT**

192 Bob Fitz Road, Johnson City, TN 37615  
salesmp@moog.com  
moogprotokraft.com