

Magnum - 801 Series

Size 8 Cavity Optoelectronic PCB Insert, 1.25mm, 850nm - Arinc 801, 803 & 804 Compliant

Front Release Optical Transmitter Insert

FEATURES

- Compliant with Arinc 664, 801, 803, 804 & 818,
- Suitable for Fast Ethernet, Gigabit Ethernet, 1x/2x/4xFibre Channel and sFPDP applications from 50Mbps to 5.0Gbps
- Maximum optical channel bit error rate less than 1×10^{-12}
- Operating temperature range from -55°C to $+85^{\circ}\text{C}$
- Shock and vibration resistant per RTCA / DO-160E
- Arcap contact insert material meets stringent EMI / RFI / ESD & EMP performance specifications
- Six pin PCB footprint with TX_Fault and TX_Dis functions
- 1.25mm ceramic optical fiber ferrule connector interface per ARINC 801
- Compatible with Arinc 600 or MIL-STD-83527 size 8Q (Quadrax) insert cavities

APPLICATIONS

Magnum - 801 series printed circuit board mounted optical transmitters enable high speed network communications over long distances in harsh environments.

- Fast or Gigabit Ethernet switches and peripherals
- Fibre Channel switches and peripherals
- Serial Rapid I/O (sRIO) interfaces
- sFPDP data links
- Video displays

This size 8 Optoelectronic cavity insert provides a rugged optical interface that is compliant with ARINC 801 1.25mm ceramic optical ferrules.

The multimode optical fiber interface supports applications where copper cable link distance, bandwidth, weight or bulk make the use of twisted pair, twinax or quadrax copper conductors unacceptable.

US Pat. #7,690,849



ARINC 801 / 1.25mm Ferrule / PCB Mounted

DESCRIPTION

Magnum - 801 series Optoelectronic size 8 cavity PCB insert transmitters consist of optoelectronic transmitter functions integrated into a printed circuit board mounted pin contact. The optical transmitters are 850nm VCSEL lasers. The transmitter input lines are driven with differential CML signals applied to the transmitter (TX+ and TX-) lines. Dual loop, temperature compensated, VCSEL drivers convert the transmitter input signals to suitable VCSEL bias and modulation currents. The TX_Fault circuit disables the optical transmitter output when the optical output power or internal current exceeds predefined limits. The fault condition is latched until reset by a toggle of TX_Dis or VCC. A CMOS fault signal is generated on the TX_Fault line upon a transmitter optical or electrical fault condition.

The optical mating interface to the Magnum - 801 series size 8 cavity insert optical transmitters is a 1.25mm ceramic fiber optic receptacle per ARINC 801. The receptacle incorporates a ferrule stub with a 50/125 μ multimode optical fiber enabling it to interface to either 62.5/125 μ or 50/125 μ optical fiber cable.

The electrical interface to the Magnum - 801 series size 8 cavity insert optical transmitters is a six position pin header suitable for thru-hole soldering to a flexible or rigid printed circuit.

Magnum - 801 series size 8 cavity insert optical transmitters are vibration isolated, environmentally hardened components designed for use in harsh environment applications.

ORDERING INFORMATION

Application	Part Number
50Mbps to 5.0Gbps	P44F-TS1G-LK

Magnum Series, 1.25mm Ferrule, Size 8 Cavity Insert, Optical Transmitter,
Multimode, 850nm, Compliant with ARINC 664, 818, 801, 803 & 804

ABSOLUTE MAXIMUM RATINGS

Absolute maximum limits mean that no catastrophic damage will occur if the product is subjected to these ratings for short periods, provided each limiting parameter is in isolation and all other parameters have values within the performance specification. It should not be assumed that limiting values of more than one parameter can be applied to the product at the same time.

Parameter	Symbol	Minimum	Typical	Maximum	Unit
Storage Temperature	T_s	-55		+100	°C
Supply Voltage	V_{CC}	-0.5		+4.5	V
TX_DIS Input Voltage	V_i	-0.5		$V_{CC} + 0.5$	V
Differential Input Voltage (p-p)	V_D			2.2	V

RECOMMENDED OPERATING CONDITIONS

Parameter	Symbol	Minimum	Typical	Maximum	Unit
Operating Temperature	T_A	-55		+85	°C
Power Supply Voltage	V_{CC}	+3.135		+3.465	V
TX Differential Input Voltage (p-p)	V_D	0.25		2.2	V
Power Supply Noise (p-p)	N_P			200	mV

ENVIRONMENTAL OPERATING CONDITIONS

Requirement	Feature	Condition	Notes
RTCA / D0-160E	ESD	HBM	2200V
RTCA / D0-160E	Vibration	3.8g ² /Hz	43G rms
RTCA / D0-160E	Shock	40.0g	6-9mS
RTCA / D0-160E	Flame Resistance		30 Seconds
RTCA / D0-160E	Damp Heat	10 Cycles	24 Hours
ARINC 801	Mating Durability	500 Cycles	<0.5dB Change
FDA / CDRH / IEC-825-1	Eye Safety	Class 1	No Safety Interlocks Required

MATERIALS

Item	Detail	Notes
Insert Shell	Arcap	
Solder Pins	Brass	
Solder Pin Plating	Gold over Nickel	
Ferrule	Ceramic	
Printed Circuits	Polyimide / FR-4	

Magnum Series, 1.25mm Ferrule, Size 8 Cavity Insert, Optical Transmitter,
Multimode, 850nm, Compliant with ARINC 664, 818, 801, 803 & 804

OPTICAL TRANSMITTERS T_A = Operating Temperature Range, V_{CC} = 3.135V to 3.465V

Parameter	Symbol	Minimum	Typical	Maximum	Unit
Optical Output Power (BER10^{-12}, PRBS= 2^7-1)	P_o	-6.5		-1.0	dBm
Optical Output Wavelength	λ_{OUT}	830	850	860	nM
Spectral Width	$\Delta\lambda_{RMS}$			0.85	nM
Extinction Ratio	ER	9.0	11.0		
Optical Modulation Amplitude (p-p)	OMA	360			μ W
Total Contributed Jitter (PRBS= 2^7-1)	T_{CJ}			60	pS

POWER SUPPLY CURRENT T_A = Operating Temperature Range, V_{CC} = 3.135V to 3.465V

Parameter	Symbol	Minimum	Typical	Maximum	Unit
Supply Current	I_{CCT}		50	95	mA

Magnum Series, 1.25mm Ferrule, Size 8 Cavity Insert, Optical Transmitter,
Multimode, 850nm, Compliant with ARINC 664, 818, 801, 803 & 804

OUTLINE DRAWING

Dimensions are shown as: inches (mm)

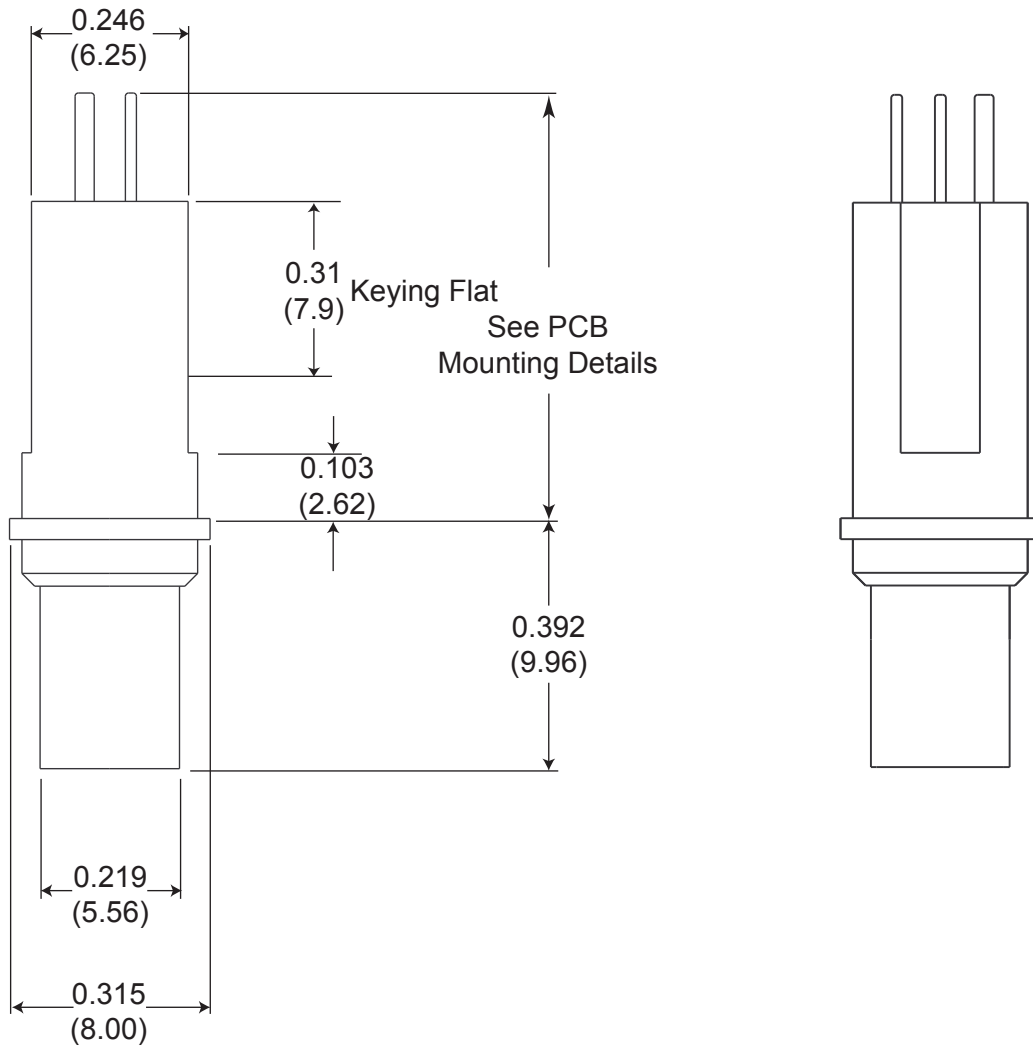
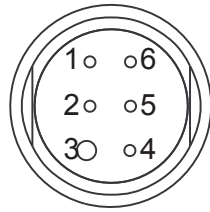

Magnum Series, 1.25mm Ferrule, Size 8 Cavity Insert, Optical Transmitter,
Multimode, 850nm, Compliant with ARINC 664, 818, 801, 803 & 804

ELECTRICAL PIN ASSIGNMENTS

Pin Number	Symbol	Description	Logic Family
1	TX_DIS	Transmit Disable - Input Logic 1: Disable Optical Output Logic 0: Enable Optical Output	CMOS Internal 4.7KΩ pulldown
2	V _{cc}	Power Supply	N/A
3	GND	Ground	N/A
4	TX_Fault	Internal TX Fault Indicator - Output Satisfactory Operation: Logic "0" Output Internal Fault: Logic "1" Output	Open Drain CMOS
5	TX-	Transmitter Data Input	CML
6	TX+	Transmitter Data Input	CML

PRINTED CIRCUIT BOARD FOOTPRINT

Dimensions are shown as: inches

PCB Hole Pattern Mounting Side View

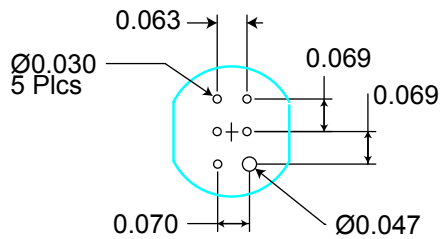

Magnum Series, 1.25mm Ferrule, Size 8 Cavity Insert, Optical Transmitter,
Multimode, 850nm, Compliant with ARINC 664, 818, 801, 803 & 804

PCB MOUNTING DETAILS

Dimensions are shown as: inches [mm]

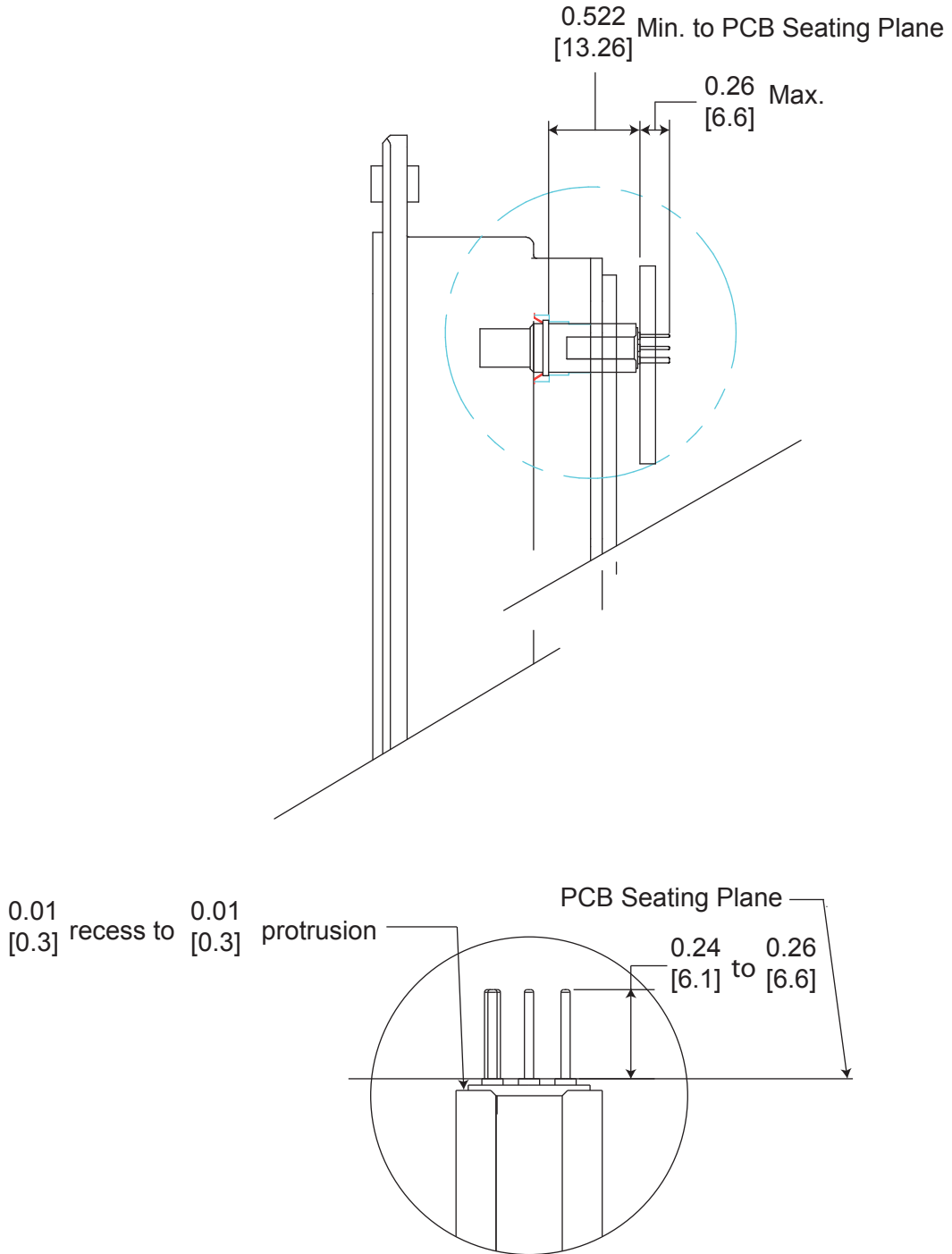

Magnum Series, 1.25mm Ferrule, Size 8 Cavity Insert, Optical Transmitter,
Multimode, 850nm, Compliant with ARINC 664, 818, 801, 803 & 804

APPLICATION SCHEMATIC For Xilinx Rocket I/O Interfaces

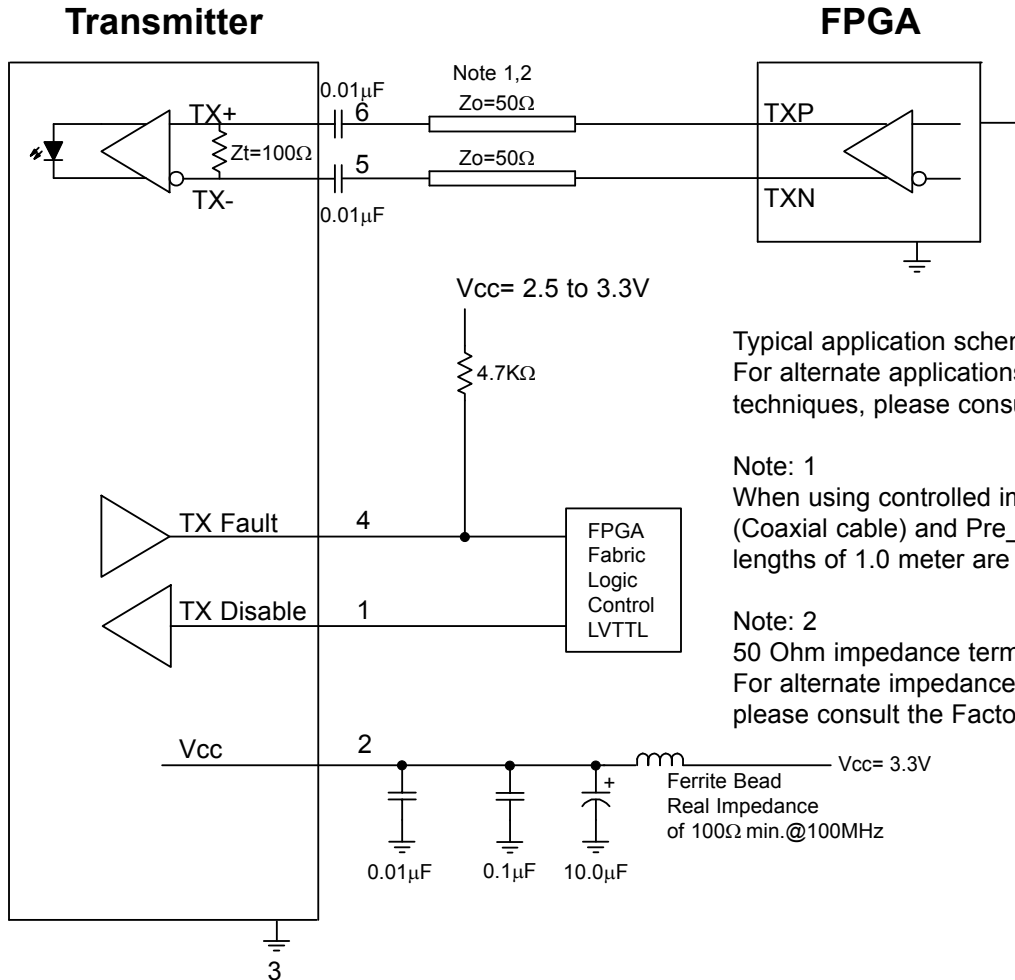

Typical application schematic shown
For alternate applications or termination
techniques, please consult the Factory

Note: 1
When using controlled impedance cable
(Coaxial cable) and Pre_Emphasis,
lengths of 1.0 meter are obtainable.

Note: 2
50 Ohm impedance termination shown.
For alternate impedance requirements,
please consult the Factory.

MOOG
PROTOKRAFT

192 Bob Fitz Road, Johnson City, TN 37615
salesmp@moog.com
moogprotokraft.com