

Mustang Series

Fast Ethernet, TFOCA II®, 100Base-TX / FX Media Converter, Multimode, 1310nm, USB Powered - 5.0VDC

Single Port, Jam Nut, USB Powered FEATURES

- Compliant with IEEE-802.3:2005 Fast Ethernet 100Base-TX and 100Base-FX
- Optical fiber link distances up to 2.0 Kilometers
- Copper Ethernet link distances up to 100 Meters (EIA/ TIA Cat-5E)
- Operating temperature range from -40°C to +85°C
- Shock, vibration and immersion resistant per MIL-STD-810
- Zinc Nickel plating meets stringent corrosion resistance requirements
- Aluminum housings are strong, durable and light weight
- TFOCA II® compliant optical fiber connector interface
- MIL-DTL-38999 electrical interface for power and signals

APPLICATIONS

Mustang series bulkhead mounted Fast Ethernet media converters enable high speed network communications over long distances in harsh environments.

- Fast Ethernet switches and peripherals
- Telecom and datacom switch / router rack-to-rack links
- Storage or computation clusters

The TFOCA II® and D38999 shells provide sealed interfaces that are water-tight to MIL-STD-810 when mated.

The multimode optical fiber interface supports applications where copper cable link distance, bandwidth, weight or bulk make the use of twisted pair, twinax or quadrx copper conductors unacceptable.

*TFOCA-II® is a registered trademark of Amphenol Fiber Systems International.

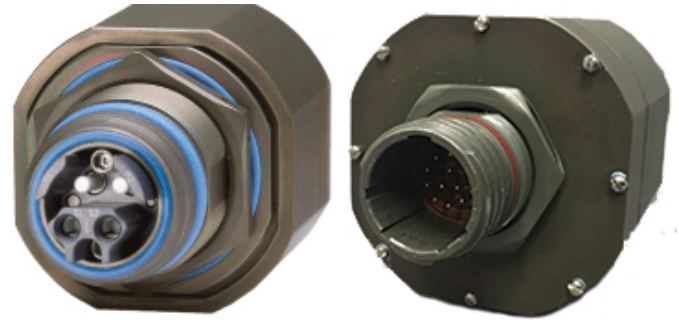

TFOCA II to D38999 / Optical to Electrical Media Converter DESCRIPTION

Mustang series Fast Ethernet media converters consist of optoelectronic transmitter and receiver functions integrated along with the 100Base-TX electrical to 100Base-FX optical media conversion circuitry into a jam-nut TFOCA II® style fiber optic connector assembly.

The optical transmitters are high output 1310nm devices. The optical receivers consist of InGaAs PIN and preamplifier assemblies and limiting post-amplifiers.

The electrical interface to the Mustang series optical media converters is a MIL-DTL-38999 cylindrical connector enabling interconnection to a cable assembly for USB power and Ethernet signal sources.

Mustang series Fast Ethernet media converters are vibration isolated, environmentally hardened components designed for use in harsh environment applications.

- Sealed against liquid and solid contaminants
- Shock and vibration resistant

ORDERING INFORMATION

Application	Product Number
Single Port 100Base-TX/FX - USB	P51J-2LCU-Fx-V

Single Port Mustang Series *TFOCA II® Connector, 100Base-TX to
100Base-FX Media Converter, Multimode, 1310nm, USB Powered (5.0VDC)

ABSOLUTE MAXIMUM RATINGS

Absolute maximum limits mean that no catastrophic damage will occur if the product is subjected to these ratings for short periods, provided each limiting parameter is in isolation and all other parameters have values within the performance specification. It should not be assumed that limiting values of more than one parameter can be applied to the product at the same time.

Parameter	Symbol	Minimum	Typical	Maximum	Unit
Storage Temperature	T_s	-55		+100	°C
Supply Voltage	V_{cc}	-0.5		8.0	V
Data Input Voltage	V_i	-0.5		V_{cc}	V

RECOMMENDED OPERATING CONDITIONS

Parameter	Symbol	Minimum	Typical	Maximum	Unit
Operating Temperature	T_A	-40		+85	°C
Supply Voltage	V_{cc}	+4.5	+5.0	+5.5	VDC
Power Supply Noise (p-p)	N_p			200	mV

INTERFACE SPECIFICATIONS COMPLIANCE

Requirement	Feature	Condition	Notes
MIL-STD-883	ESD	Class II	2200V
MIL-STD-810	Vibration	3.8g ² /Hz	43G rms
MIL-STD-810	Shock	40.0g	6-9mS
MIL-STD-1344	Flame Resistance	Method 1012	30 Seconds
MIL-STD-1344	Damp Heat	10 Cycles	24 Hours
TFOCA II	Mating Durability	2000 Cycles	EIA/TIA-455-21
FDA / CDRH / IEC-825-1	Eye Safety	Class 1	No Safety Interlocks Required

MATERIALS

Item	Detail	Notes
D38999 & TFOCA II Cylindrical Shells	Aluminum	
D38999 & TFOCA II Finish	ZN-NI, OD-CD or NI	
D38999 Inserts	Thermoplastic	
Interfacial Seals	Elastomer	
Optical Ferrules	Zirconia	
Printed Circuits	FR-4	
Housing	Aluminum	

Single Port Mustang Series *TFOCA II® Connector, 100Base-TX to
100Base-FX Media Converter, Multimode, 1310nm, USB Powered (5.0VDC)

TRANSMITTERS T_A = Operating Temperature Range

Parameter	Symbol	Minimum	Typical	Maximum	Unit
Optical Output Power	P_o	-15.0		-8.0	dBm
Optical Output Wavelength	λ_{OUT}	1260	1310	1380	nm

RECEIVERS T_A = Operating Temperature Range

Parameter	Symbol	Minimum	Typical	Maximum	Unit
Optical Sensitivity	P_i	-31.5		-1.0	dBm
Optical Wavelength	λ_{IN}	1100		1590	nm

SUPPLY CURRENT T_A = Operating Temperature Range

Parameter	Symbol	Minimum	Typical	Maximum	Unit
Supply Current per Port	I_{CCT}		450	500	mA

OPTICAL FIBER LINK DISTANCES

Application	Fiber Specification	Distance
Fast Ethernet - IEEE 802.3u	62.5/125 μ - 500MHz*Km	2.0Km
FDDI PMD ISO / IEC 9314-3	50/125 μ - 500MHz*Km	2.0Km

ETHERNET COPPER CABLE LINK DISTANCES

Application	Cable Specification	Distance
Fast Ethernet - IEEE 802.3u	TIA/EIA-568-B Cat 5*	100M

*for other transmission media, please consult the factory

Single Port Mustang Series *TFOCA II® Connector, 100Base-TX to
100Base-FX Media Converter, Multimode, 1310nm, USB Powered (5.0VDC)

OUTLINE DRAWING

Dimensions are shown as: inches [mm]

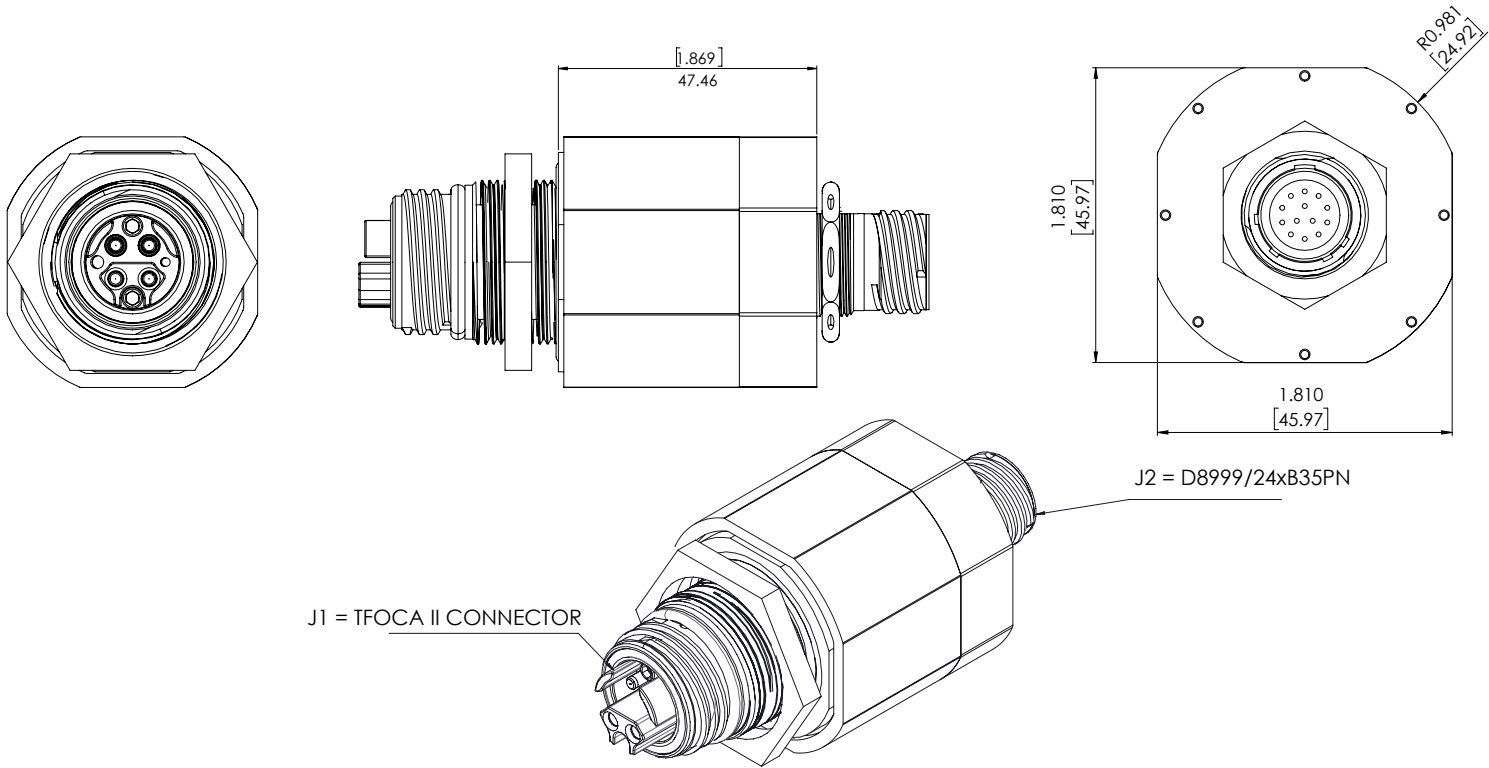

PORT / FUNCTION ASSIGNMENTS

Port #	Function
J1	1x100Base-FX
J2	1x100Base-TX + 5.0VDC

Panel Cutout Dimensions

Dimensions are shown as: inches

Panel Thickness: 0.12 to 0.26

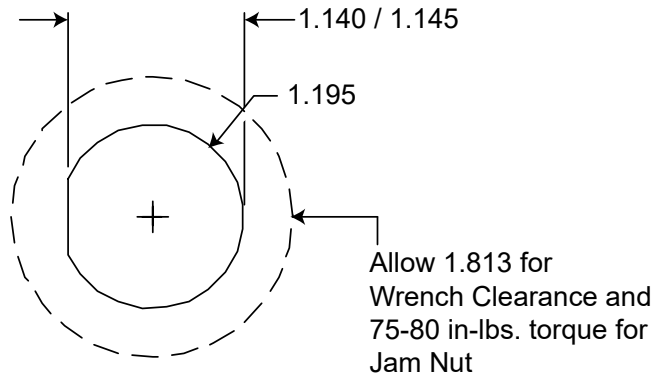

Single Port Mustang Series *TFOCA II® Connector, 100Base-TX to
100Base-FX Media Converter, Multimode, 1310nm, USB Powered (5.0VDC)

J1 OPTICAL INSERT PIN FUNCTIONS Ethernet Port and Pin Assignments

Top

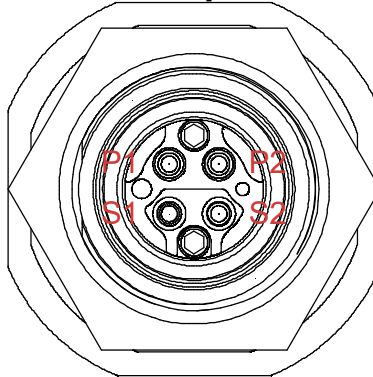

Front view of the TFOCA II media converter optical
insert shown - fiber optic cable plug opposite

OPTICAL PORT ASSIGNMENTS

TFOCA II OPTICAL INTERFACE		
PORT NUMBER	RX	TX
0	P2	S2

Single Port Mustang Series *TFOCA II® Connector, 100Base-TX to
100Base-FX Media Converter, Multimode, 1310nm, USB Powered (5.0VDC)

J2 / D38999/24WD35PN ELECTRICAL PIN FUNCTIONS TOP

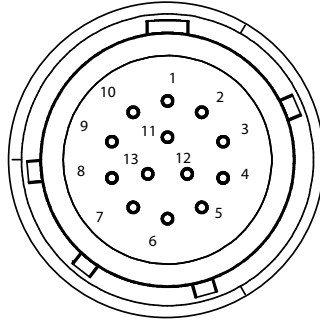

Front view of the J2 connector shown - mating cable plug opposite

PIN #	PORT	FUNCTION	RJ-45 Eq. Pin #	Logic Family
1	N/A	NC	N/A	N/A
2	0	TX+	1	IEEE-802.3:2005 1000Base-T
3	0	TX-	2	IEEE-802.3:2005 1000Base-T
4	0	RX+	3	IEEE-802.3:2005 1000Base-T
5	0	RX-	6	IEEE-802.3:2005 1000Base-T
6	N/A	NC	N/A	N/A
7	0	NC	5	IEEE-802.3:2005 1000Base-T
8	0	NC	4	IEEE-802.3:2005 1000Base-T
9	0	NC	8	IEEE-802.3:2005 1000Base-T
10	0	NC	7	IEEE-802.3:2005 1000Base-T
11	N/A	NC	N/A	N/A
12	0	5VDC Rtn	N/A	N/A
13	0	5VDC	N/A	N/A

TX functions are outputs, RX functions are inputs.

APPENDIX A1 PART NUMBER OPTIONS

P51 J - 2 L C U - F x x - V

Shell Configuration

P51= TFOCA II
Receptacle

Shell Configuration

J = Jam Nut

Channels (TX+RX)

2= 1TX + 1RX

Wavelength

L= 1310nM

Power Supply

C= 5VDC

Fiber Optic Interface

U = 125 Mbps

Shell Size Code

F = TFOCA II

Shell Plating

F = NI

W = OD CD / NI

Z = ZN / NI

P = TFOCA II Plating = Hard Anodized Gray

D38999/Enclosure = OD-CAD

B = TFOCA II Plating = ZN / NI

D38999/Enclosure = OD/CD

Shell Polarization

(leave blank) **_** = N

A = A

B = B

C = C

D = D

Electrical Interface

V = MIL-DTL-38999

