

Stingray Series

Gigabit Ethernet, M83526/21-02, 1000Base-T / LX Media Converter, Single Mode, 1310nM

Dual Port, Jam Nut

FEATURES

- Compliant with IEEE-802.3:2005 Gigabit Ethernet 1000Base-T and 1000Base-LX
- Optical fiber link distances up to 10.0Kilometers
- Copper link distances up to 100 Meters (EIA/TIA Cat-5E)
- Operating temperature range from -40°C to +85°C
- Shock, vibration and immersion resistant per MIL-STD-810
- Zinc-Nickel finish meets stringent corrosion resistance specifications
- Aluminum housings are strong, durable and light weight
- M83526/21-02 compliant optical fiber connector interface
- MIL-DTL-38999 electrical interface for power and signals

APPLICATIONS

Stingray series bulkhead mounted Gigabit Ethernet media converters enable high speed network communications over long distances in harsh environments.

- Gigabit Ethernet switches and peripherals
- Telecom and datacom switch / router rack-to-rack links
- Storage or computation clusters

The M83526/21-02 and D38999 shells provide sealed interfaces that are water-tight to MIL-STD-810 when mated.

The single mode optical fiber interface supports applications where copper cable link distance, bandwidth, weight or bulk make the use of twisted pair, twinax or quadax copper conductors unacceptable.



M83526/21-02 to MIL-DTL-38999 Optical Media Converter

DESCRIPTION

Stingray series Gigabit Ethernet media converters consist of optoelectronic transmitter and receiver functions integrated along with the 1000Base-T electrical to 1000Base-LX optical media conversion circuitry into a jam-nut M83526/21-02 fiber optic connector assembly.

The optical transmitters are high output 1310nM laser devices. The optical receivers consist of InGaAs PIN and preamplifier assemblies and limiting post-amplifiers.

The optical interface to the Stingray series optical media converters is a M83526/21-02 jam nut fiber optic connector with an integral protection cap and lanyard.

The electrical interface to the Stingray series optical media converters is a MIL-DTL-38999 cylindrical connector enabling interconnection to a customer supplied cable assembly for 28VDC power and Gigabit Ethernet signal sources.

Stingray series Gigabit Ethernet media converters are vibration isolated, environmentally hardened components designed for use in harsh environment applications.

- Sealed against liquid and solid contaminants
- Shock and vibration resistant

ORDERING INFORMATION

Application	Product Number
Dual Port 1000Base-T/LX - 28VDC	P83J-4LAT-FZ-V
See Appendix A1 for more part number options	

ABSOLUTE MAXIMUM RATINGS

Absolute maximum limits mean that no catastrophic damage will occur if the product is subjected to these ratings for short periods, provided each limiting parameter is in isolation and all other parameters have values within the performance specification. It should not be assumed that limiting values of more than one parameter can be applied to the product at the same time.

Parameter	Symbol	Minimum	Typical	Maximum	Unit
Storage Temperature	T_s	-55		+100	°C

RECOMMENDED OPERATING CONDITIONS

Parameter	Symbol	Minimum	Typical	Maximum	Unit
Operating Temperature	T_A	-40		+85	°C
Power Supply Voltage	V_{CC}	18.0		36.0	VDC
Power Supply Noise (p-p)	N_p			200	mV

SPECIFICATIONS COMPLIANCE

Requirement	Feature	Condition	Notes
MIL-STD-883	ESD	Class II	2200V
MIL-STD-810	Vibration	3.8g ² /Hz	43G rms
MIL-STD-810	Shock	40.0g	6-9mS
MIL-STD-810	Immersion	1.0 meter	2 .0Hours
MIL-STD-1344	Flame Resistance	Method 1012	30 Seconds
MIL-STD-1344	Damp Heat	10 Cycles	24 Hours
FDA / CDRH / IEC-825-1	Eye Safety	Class 1	No Safety Interlocks Required

MATERIALS

Item	Detail	Notes
Conector Shells and Housings	Aluminum Alloy	
M83526 Connector Finish	Zinc Nickel	
Insert	Aluminum Alloy	
Interfacial Seal	Elastomer	
Alignment Sleeves	Zirconia	
Printed Circuits	FR-4	

Dual Port Stingray Series MIL-DTL-83526 Connector, 1000Base-T to
1000Base-LX Media Converter, Single Mode, 1310nm, 28VDC

TRANSMITTERS T_A = Operating Temperature Range

Parameter	Symbol	Minimum	Typical	Maximum	Unit
Optical Output Power	P_o	-9.5		-3.0	dBm
Optical Output Wavelength	λ_{OUT}	1285	1310	1335	nM

RECEIVERS T_A = Operating Temperature Range

Parameter	Symbol	Minimum	Typical	Maximum	Unit
Optical Sensitivity	P_i	-19.0		0.0	dBm
Optical Wavelength	λ_{IN}	1100		1590	nM

SUPPLY CURRENT T_A = Operating Temperature Range

Parameter	Symbol	Minimum	Typical	Maximum	Unit
Supply Current per Port @ 28Vdc	I_{CCT}		100	150	mA

OPTICAL FIBER LINK DISTANCES

Application	Fiber	Distance
Gigabit Ethernet - IEEE 802.3:2005 1000Base-LX	9/125 μ SMF	10.0Km

Dual Port Stingray Series MIL-DTL-83526 Connector, 1000Base-T to
1000Base-LX Media Converter, Single Mode, 1310nm, 28VDC

OUTLINE DRAWING

Dimensions are shown as: inches [mm]

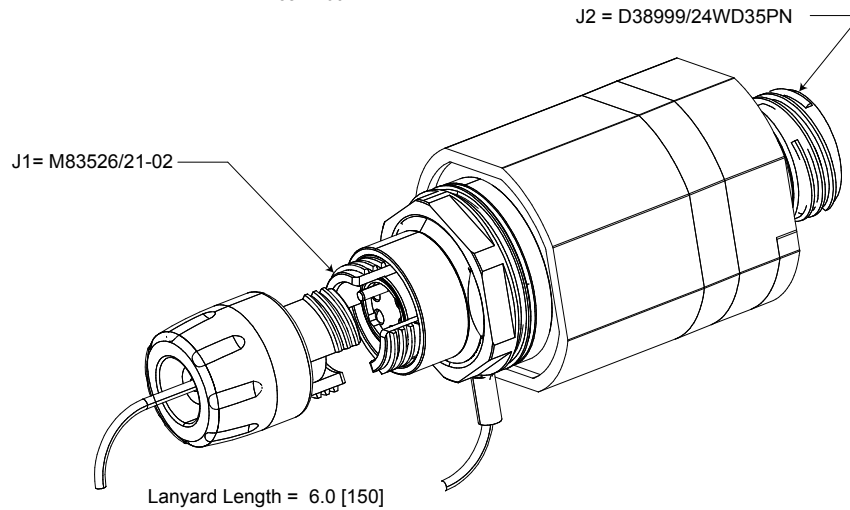
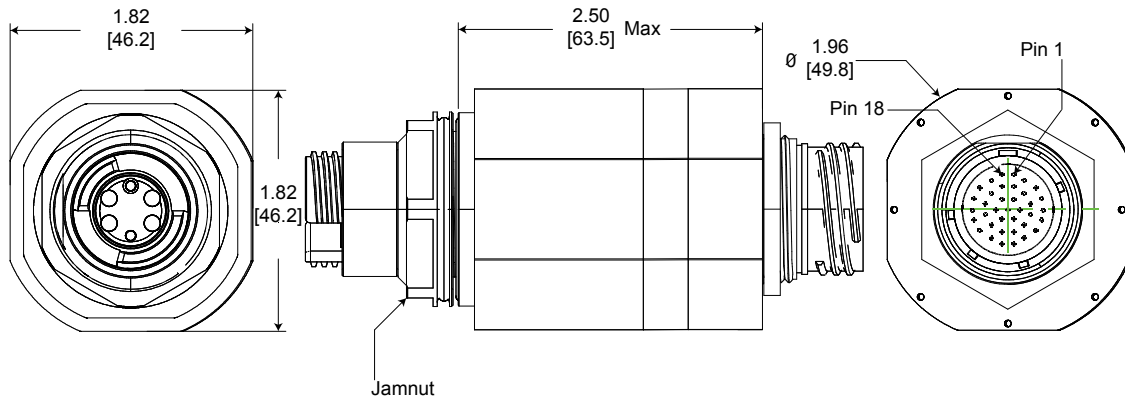

PORT / FUNCTION ASSIGNMENTS

Port #	Function
J1	2x1000Base-LX
J2	2x1000Base-T + 28VDC

Panel Cutout Dimensions

Dimensions are shown as: inches [mm]

Panel Thickness: 3.0 - 6.5mm

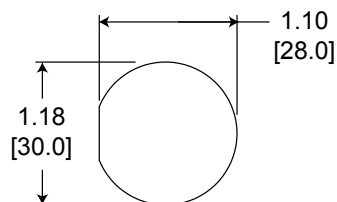

Dual Port Stingray Series MIL-DTL-83526 Connector, 1000Base-T to
1000Base-LX Media Converter, Single Mode, 1310nm, 28VDC

J1 PIN FUNCTIONS

Ethernet Port and Pin Assignments

Top

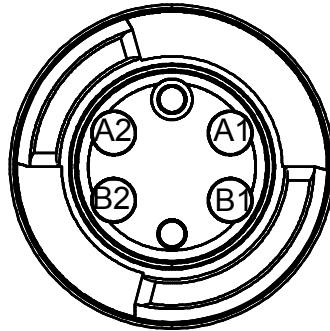

Front view of the media converter M83526/21-02 optical
insert shown, fiber optic cable plug
opposite - see Appendix A1
for mating connector details

OPTICAL PORT ASSIGNMENTS

PORT NUMBER	TX	RX
0	B1	A1
1	B2	A2

Dual Port Stingray Series MIL-DTL-83526 Connector, 1000Base-T to
1000Base-LX Media Converter, Single Mode, 1310nm, 28VDC

**J2 / D38999/24WD35PN ELECTRICAL PIN FUNCTIONS
TOP**

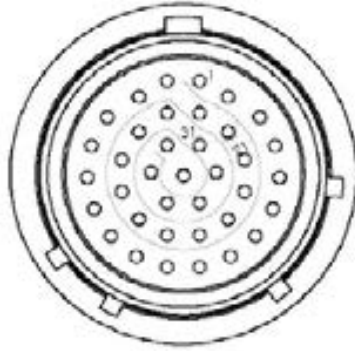

Front view of the J2 connector shown - mating cable plug opposite

PIN #	PORT	FUNCTION	RJ-45 Eq. Pin #	Logic Family
1	0	MDC+	4	IEEE-802.3:2005 1000Base-T
2	0	MDC-	5	
3	0	MDD+	7	
4	0	MDD-	8	
5	0 - 1	28VDC Rtn	N/A	N/A
6	1	MDD-	8	IEEE-802.3:2005 1000Base-T
7	1	MDD+	7	
8	1	MDC-	5	
9	1	MDC+	4	
10	1	MDB-	6	
11	1	MDB+	3	
12	1	MDA-	2	
13	1	MDA+	1	
14	0 - 1	28VDC	N/A	N/A
15	0	MDA+	1	IEEE-802.3:2005 1000Base-T
16	0	MDA-	2	
17	0	MDB+	3	
18	0	MDB-	6	

All others are signal GND

Dual Port Stingray Series MIL-DTL-83526 Connector, 1000Base-T to
1000Base-LX Media Converter, Single Mode, 1310nm, 28VDC

APPENDIX A1

PART NUMBER OPTIONS

M83526/21-02 Media Converter, Dual Port, Gigabit Ethernet / Single Mode / 1310nm

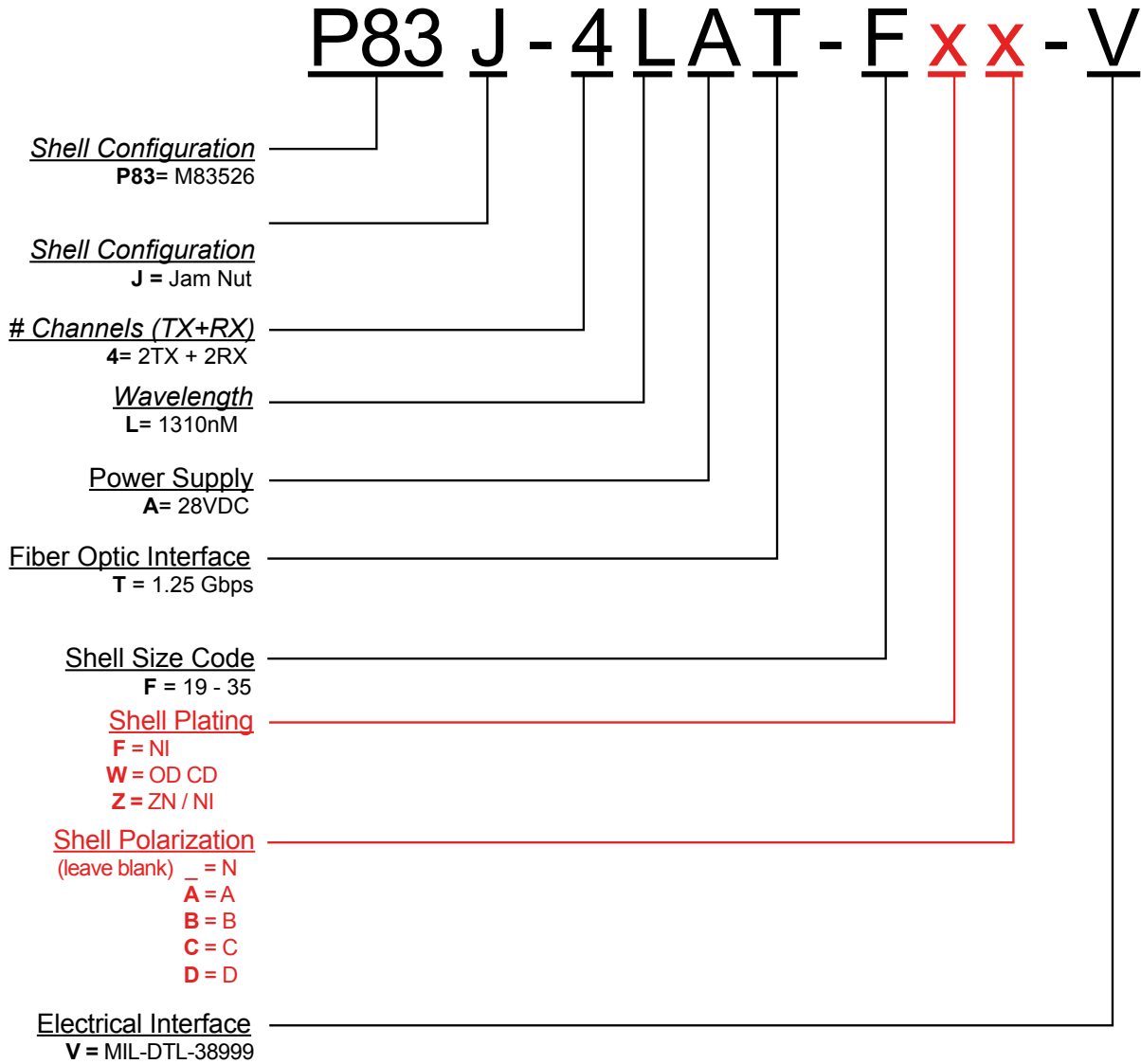

192 Bob Fitz Road, Johnson City, TN 37615
salesmp@moog.com
moogprotokraft.com

Product and company names listed are trademarks
or trade names of their respective companies.

© 2019 Moog, Inc. All rights reserved.

P83J-4LAU-FZ-V-DS
October 10, 2014 - Released