

Sabre Series

D38999 Size 11-02 Optical Transceiver, PCB Mount, *ELIO[®], 850nm, ARINC 818, 803 & 804

Single Port, Jam Nut

FEATURES

- Compliant with ARINC 664, 818, 803 & 804
- Suitable for Fast Ethernet, Gigabit Ethernet, 1x/2x/4x Fibre Channel and sFPDP applications from 100Mbps to 4.25Gbps
- Maximum optical channel bit error rate less than 1×10^{-12}
- Operating temperature range from -55°C to +85°C
- Shock and vibration resistant per RTCA / DO-160E
- Olive drab cadmium over electroless nickel plating meets stringent corrosion performance specifications
- Twelve pin PCB footprint with Loss of Signal (LOS) function
- ELIO[®] 2.5mm ceramic optical fiber ferrule connector interface per EN 4531, ABS 1379 and ARINC 801
- Compatible with Mil-Dtl-38999 ELIO[®] size 11-02 connectors

APPLICATIONS

Sabre series 38999 size 11-02 optical transceivers enable high speed network communications over long distances in harsh environments.

- Fast or Gigabit Ethernet switches and peripherals
- Fibre Channel switches and peripherals
- ARINC 818 video interfaces
- sFPDP data links

Sabre series 38999 size 11-02 optical transceivers provide a rugged optical interface that is compliant with ELIO[®] 2.5mm ceramic optical ferrules*.

The multimode optical fiber interface supports applications where copper cable link distance, bandwidth, weight or bulk make the use of twisted pair, twinax or quadax copper conductors unacceptable.

*ELIO[®] is a registered trademark of Souriau Connection Technology



One Duplex Channel Operating from 100Mbps to 4.25Gbps

DESCRIPTION

Sabre series 38999 size 11-02 optical transceivers consist of optoelectronic receiver functions integrated into a wall mount D38999 optical connector. The optical transmitters are 850nm VCSEL lasers. The transmitter input lines are driven with differential CML signals applied to the transmitter (TX+ and TX-) lines. The TX_Fault circuit disables the optical transmitter output when the optical output power or internal current exceeds predefined limits. A CMOS fault signal is generated on the TX_Fault line upon a transmitter optical or electrical fault condition. The fault signal is latched until reset by a toggle of TX_Dis or VCC.

The optical receivers consist of PIN and preamplifier assemblies and limiting post-amplifiers. Outputs from the receivers consist of differential CML data signals on the receiver (RX+ and RX-) lines and single ended CMOS indicator functions on the Loss of Signal (LOS) lines. The receiver data lines are squelched upon LOS assertion, preventing errant data generation when an invalid incoming optical signal is presented to the transceiver.

The optical mating interface of the Sabre series 38999 size 11-02 optical receivers is a Souriau D38999 ELIO[®] fiber optic cable plug per EN 4531. The electrical interface to the Sabre series D38999 size 11-02 optical transceiver is a 12 position pin header suitable for thru-hole soldering to a flexible or rigid printed circuit.

Sabre series D38999 size 11-02 optical receivers are vibration isolated, environmentally hardened components designed for use in harsh environment applications.

ORDERING INFORMATION

Application	Part Number
0.1Gbps to 3.19 Gbps	P86J-2S1E-BW
3.2Gbps to 4.25Gbps	P86J-2S1G-BW

See Appendix A3 for more part number options

ABSOLUTE MAXIMUM RATINGS

Absolute maximum limits mean that no catastrophic damage will occur if the product is subjected to these ratings for short periods, provided each limiting parameter is in isolation and all other parameters have values within the performance specification. It should not be assumed that limiting values of more than one parameter can be applied to the product at the same time.

Parameter	Symbol	Minimum	Typical	Maximum	Unit
Storage Temperature	T_s	-55		+100	°C
Supply Voltage	V_{CC}	-0.5		+4.5	V
RX Output Current	I_o			50	mA
Differential Input Voltage (p-p)	V_D			2.2	V

RECOMMENDED OPERATING CONDITIONS

Parameter	Symbol	Minimum	Typical	Maximum	Unit
Operating Temperature	T_A	-55		+85	°C
Power Supply Voltage	V_{CC}	+3.135		+3.465	V
TX Common Mode Voltage	V_{CM}			2.0	V
TX Differential Input Voltage (p-p)	V_D	0.25		2.2	V
Power Supply Noise (p-p)	N_P			200	mV

SPECIFICATIONS COMPLIANCE

Requirement	Feature	Condition	Notes
RTCA / D0-160E	ESD	Class II	2200V
RTCA / D0-160E	Vibration	3.8g ² /Hz	43G rms
RTCA / D0-160E	Shock	40.0g	6-9mS
RTCA / D0-160E	Flame Resistance	Method 1012	30 Seconds
RTCA / D0-160E	Damp Heat	10 Cycles	24 Hours
ARINC 801	Mating Durability	500 Cycles	<0.5dB Change
FDA / CDRH / IEC-825-1	Eye Safety	Class 1	No Safety Interlocks Required

MATERIALS

Item	Detail	Notes
38999 Shell	Aluminum	
38999 Shell Plating	OD-CD, NI or ZN-NI	QQ-P-416, QQ-N-290
Insert	Arcap	
Solder Pins	Brass	
Solder Pin Plating	Gold	
Ferrule	Ceramic	
Printed Circuits	Polyimide / FR-4	

Sabre Series Mil-Dtl-38999 / ELIO Size 11-02 Optical Transceiver,
Multimode, 850nm, Arinc 664, 818, 803 & 804 Compliant

OPTICAL TRANSMITTERS T_A = Operating Temperature Range, V_{CC} = 3.135V to 3.465V

Parameter	Symbol	Minimum	Typical	Maximum	Unit
Optical Output Power (BER<10 ⁻¹² , PRBS= 2 ⁷ -1)	P_o	-6.5		-1.0	dBm
Optical Output Wavelength	λ_{OUT}	830	850	860	nM
Spectral Width	$\Delta\lambda_{RMS}$			0.85	nM
Extinction Ratio	ER	6.0			dB

OPTICAL RECEIVERS T_A = Operating Temperature Range, V_{CC} = 3.135V to 3.465V

Parameter	Symbol	Minimum	Typical	Maximum	Unit
Optical Sensitivity (BER<10 ⁻¹² , ER=9.0) xxxx-xxD-xx @ 100Mbps to 1.25Gbps xxxx-xx1D-xx @ 2.125Gbps xxxx-xx1E-xx @ 2.5Gbps to 3.19Gbps xxxx-xx1G-xx @ 3.2Gbps to 4.25Gbps	P_i	-17.0 -15.0 -15.0 -14.0		0.0	dBm
Optical Wavelength	λ_{IN}	830		860	nM

POWER SUPPLY CURRENT T_A = Operating Temperature Range, V_{CC} = 3.135V to 3.465V

Parameter	Symbol	Minimum	Typical	Maximum	Unit
Supply Current	I_{CCT}		165	200	mA

OUTLINE DRAWING

Dimensions are shown as: inches [mm]

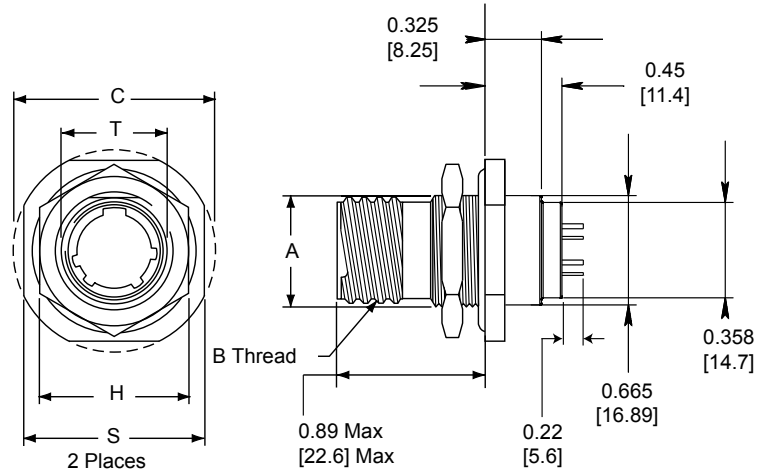

Outline Dimensions

Shell Size Code	Shell Size	A +0.000 -0.010	B Thread Class 2A 0.1P-0.3L-TS (Plated)	C Max	H Hex +/-0.010	S +/-0.010	T +0.010 -0.010
B	11	0.769 (19.53)	0.7500	1.386 (35.20)	.998 (25.35)	1.250 (31.75)	0.822 (20.88)

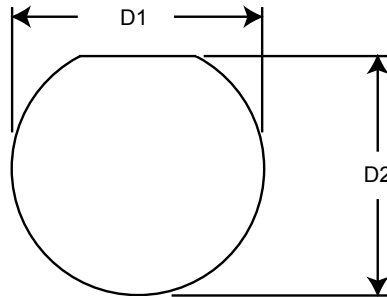

Panel Cutout Dimensions

Shell Size Code	Shell Size	D1 +0.025 / -0.00	D2 +0.00 / -0.25
B	11	0.825 (20.96)	0.770 (19.59)

OPTICAL TRANSCEIVER INSERT ARRANGEMENT

TOP
Optical Interface

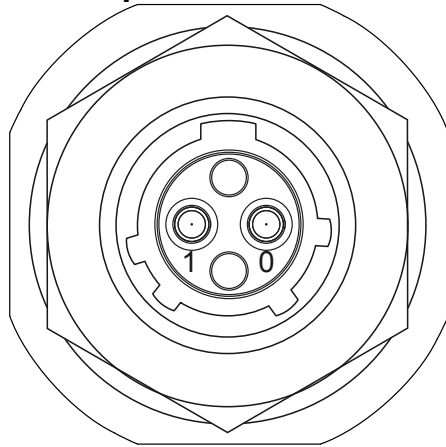

Front face of the optical dual receiver insert shown, fiber optic cable plug opposite - see Appendix A2 for details

TOP
Electrical Interface

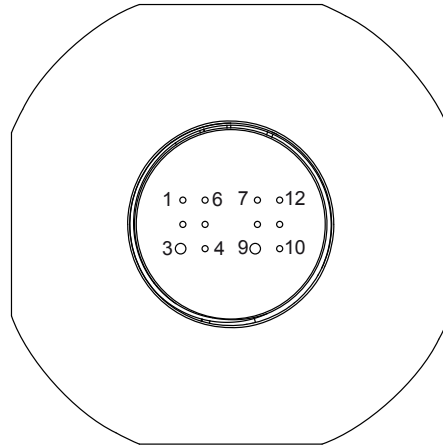

Back face of the optical dual receiver insert shown - see Printed Circuit Board Footprint and Electrical Pin Assignment pages for details

OPTICAL TRANSCEIVER PORT / PIN ASSIGNMENTS

OPTICAL		ELECTRICAL
Port #	Function	Pin # (-,+)
0	RX	5,6
1	TX	11,12

RECEPTACLE PROTECTION CAPS

*MIL-DTL 38999/33 PROTECTIVE CAP PART NUMBERS

MS RECEPTACLE CAP P/N

See Appendix A1

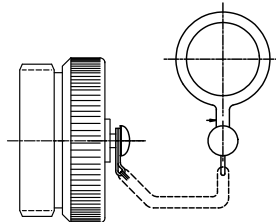

*See DSCC or SAE QPL for Approved Suppliers

ELECTRICAL PIN ASSIGNMENTS

Pin Number	Symbol	Description	Logic Family
1	GND	Ground	N/A
2	V _{CCR_X}	RX Power Supply - Input	N/A
3	GND	Ground	N/A
4	LOS	Loss of Signal - Output Satisfactory Optical Input: Logic "0" Output Unsatisfactory Optical Input: Logic "1" Output	Open Drain CMOS
5	RX-	Receiver Data - Output	CML
6	RX+	Receiver Data - Output	CML
7	TX_DIS	TX Disable - Input Logic 1: Disable Optical Output Logic 0: Enable Optical Output	N/A
8	V _{CCT_X}	TX Power Supply - Input	N/A
9	GND	Ground	N/A
10	TX_Fault	Internal TX Fault Indicator - Output Satisfactory Operation: Logic "0" Output Internal Fault: Logic "1" Output	Open Drain CMOS
11	TX-	Transmitter Data - Input	CML
12	TX+	Transmitter Data - Input	CML

PRINTED CIRCUIT BOARD FOOTPRINT

Dimensions are shown as: inches

PCB Hole Pattern Mounting Side View

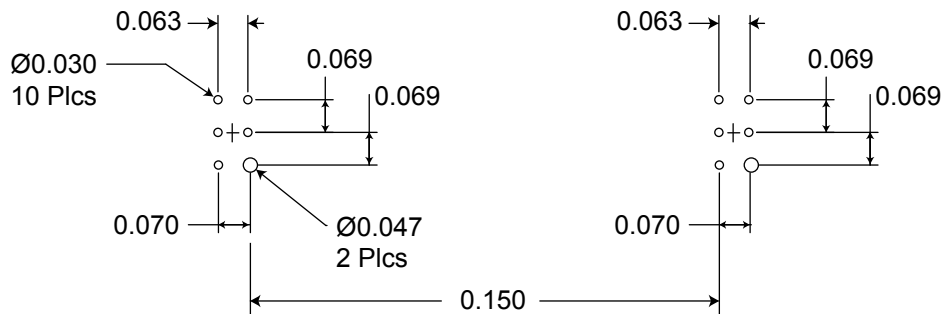

APPLICATION SCHEMATIC

For Xilinx Rocket I/O Interfaces

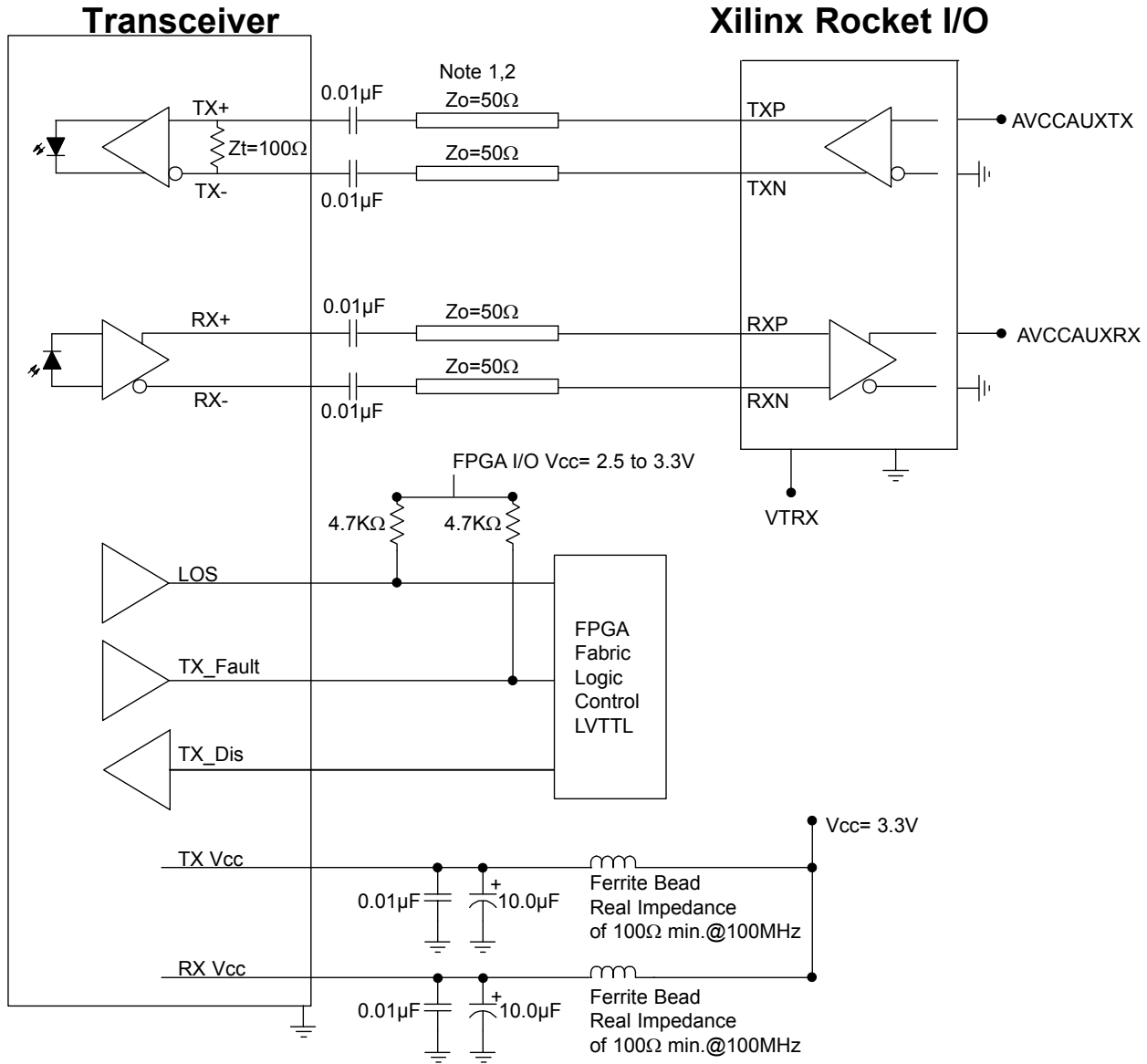

Typical application schematic shown
For alternate applications or termination
techniques, please consult the Factory

Note: 1
When using controlled impedance cable
(Coaxial cable) and Pre_Emphasis,
lengths of 1.0meter are obtainable.

Note: 2
50 Ohm impedance termination shown.
For alternate impedance requirements,
please consult the Factory.

APPENDIX A1

RECEPTACLE PROTECTION CAPS

*MIL-DTL-38999/33 PROTECTION CAP PART NUMBERS

MS RECEPTACLE CAP P/N

*D38999/33x11N

*x = protection class (F, W or Z)

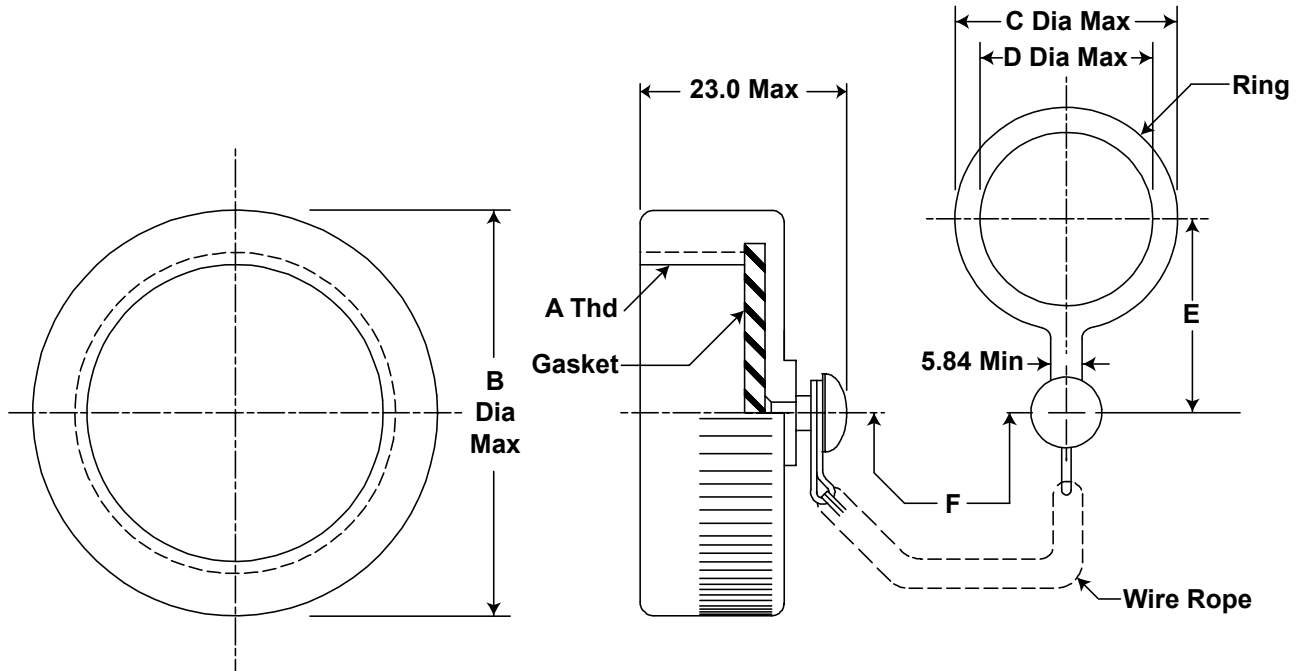

APPENDIX A1

Mating Fiber Optic Connectors and Termini

ELIO® Plug Connector

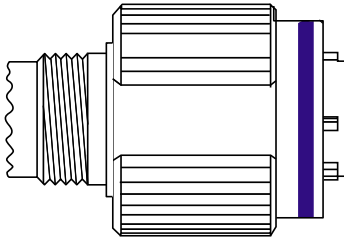

8D	5	E	11	W	02	A	N
Shell type: 5 = Plug							
Designation: E							
Shell size: 11							
Plating							
W: Olive drab cadmium							
F: Nickel							
Insert arrangement: 02							
Insert: Male							
Polarization N, A, B, C, D, E							

ELIO® multimode contact

Ordering information

ELIO	09N	G	L	A
Cable external diameter & Contact sealing:				
09N: 0.9 ^{±0.1} mm. Non waterproof				
18N: from 1.5mm to 1.9mm. Non waterproof				
18W: 1.8 ^{±0.1} mm. Waterproof				
20N: from 1.7mm to 2.1mm. Non waterproof				
20W: 2.0 ^{±0.1} mm. Waterproof				
Fibre type:				
G: ELIO® Multimode fibre, 125 micrometers cladding				
Boot type:				
L: Long boot				
S: Short boot				
N: No boot (non waterproof version only)				
Contact version index				



Note: For ABS1379/EN4531 cross reference, please consult us.

APPENDIX A3 PART NUMBER OPTIONS

Sabre 11-02 Series

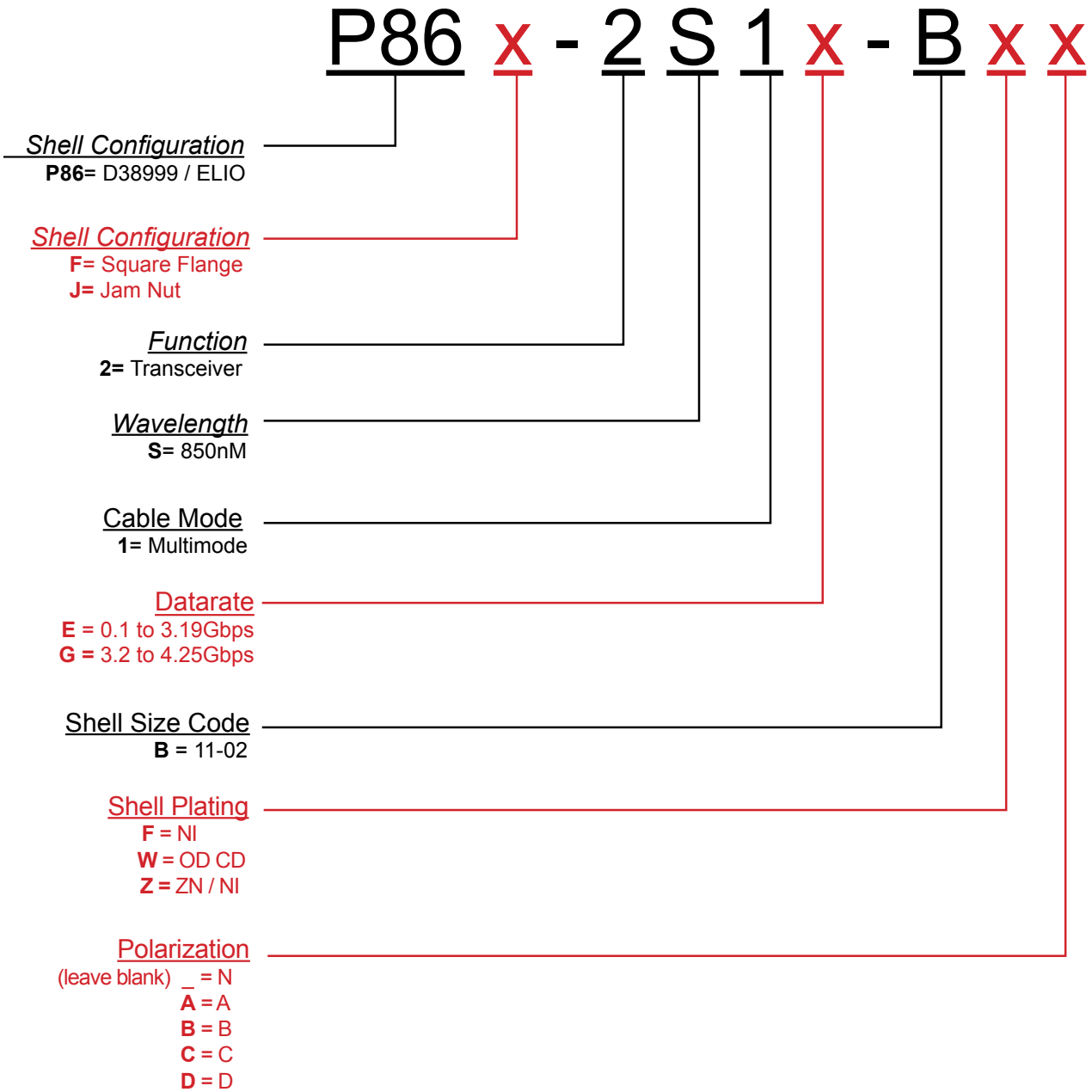

Other wavelength, mounting and port count options are available.
Please consult the Protokraft website for alternate configurations.



192 Bob Fitz Road, Johnson City, TN 37615
salesmp@moog.com
moogprotokraft.com