

Viking Series

10/100Base-TX/FX, Auto MDI/MDIX,
Autonegotiable MIL-DTL-38999,
Unmanaged Ethernet Switch

6 Port (4+2), Flange Mounted

FEATURES

- 4x10/100Base-TX nonblocking wire speed copper Ethernet ports per IEEE 802.3:2005
- 2x100Base-FX fiber Ethernet ports per IEEE 802.3:2005
- Electrical cable links up to 100 Meters (EIA/TIA Cat-5E)
- Fiber optic link distances up to 2.0 Kilometers per IEEE 802.3
- Operating temperature range from -40°C to +85°C
- Full duplex flow control per IEEE Std 802.3x and half duplex back pressure, symmetric and asymmetric
- Shock, vibration and immersion resistant per MIL-STD-810
- OD-CD, NI or ZN-NI plating options for enhanced corrosion resistance
- Aluminum connector shells and housing are strong, durable and light weight
- Auto sensing of half or full duplex operation

APPLICATIONS

Viking series 4+2 port Ethernet switches enable high speed network communications in harsh environments.

- Civil and military vehicle networking
- Aerospace and naval platform networks
- Unmanaged Ethernet switch applications

The MIL-DTL-38999, Series III connectors provide a sealed interface that is water-tight to Mil-Std-810 when mated.



D38999 In-Line 4+2 Port 10/100Base-TX / FX Ethernet Switch

DESCRIPTION

Viking series 10/100Base-TX/FX unmanaged Ethernet switches consist of 4x10/100Base-TX ports plus 2x100Base-FX ports in a wall or floor mounted inline MIL-DTL-38999 connector assembly.

The Viking series Ethernet switch offers two separate D38999 Ethernet connector interfaces. One interface is a D38999/19-35 with 4x10/100Base-TX Ethernet ports compliant with IEEE-802.3U:2005 plus the 28VDC interface. The other interface is a D38999/19-11 with 2x100Base-FX Ethernet fiber optic ports per IEEE-802.3U:2005.

The Viking 4+2 port Ethernet switch is a highly integrated and extremely rugged solution for vehicle and mobile networking applications. Its small size, light weight and low power requirements make it an excellent fit for next generation networks.

Viking series 4+2 port Ethernet switches are vibration isolated, environmentally hardened components designed for use in harsh environment applications.

- Sealed against liquid and solid contaminants
- Shock and vibration resistant

ORDERING INFORMATION

Application	Product Number
10/100Base-TX/FX - 28VDC	V42F-6LAU-FW

See Appendix A2 for more part number options

Six Port (4+2) Viking Series D38999,
10/100Base-TX / FX Unmanaged Ethernet Switch

ABSOLUTE MAXIMUM RATINGS

Absolute maximum limits mean that no catastrophic damage will occur if the product is subjected to these ratings for short periods, provided each limiting parameter is in isolation and all other parameters have values within the performance specification. It should not be assumed that limiting values of more than one parameter can be applied to the product at the same time.

Parameter	Symbol	Minimum	Typical	Maximum	Unit
Storage Temperature	T_s	-55		+100	°C

RECOMMENDED OPERATING CONDITIONS

Parameter	Symbol	Minimum	Typical	Maximum	Unit
Operating Temperature	T_A	-40		+85	°C
Supply Voltage	V_{CC}	+18.0	28.0	+36.0	V
Power Supply Noise (p-p)	N_p			200	mV

INTERFACE SPECIFICATIONS COMPLIANCE

Requirement	Feature	Condition	Notes
MIL-STD-883	ESD	Class II	2200V
MIL-STD-810	Vibration	3.8g ² /Hz	43G rms
MIL-STD-810	Shock	40.0g	6-9mS
MIL-STD-810	Immersion	1.0 meter	2 .0Hours
MIL-STD-1344	Flame Resistance	Method 1012	30 Seconds
MIL-STD-1344	Damp Heat	10 Cycles	24 Hours
FDA / CDRH / IEC-825-1	Eye Safety	Class 1	No Safety Interlocks Required

MATERIALS

Item	Detail	Notes
Shell and housing	Aluminum Alloy	
Plating	OD-CD, NI or ZN-NI	
Insert	Thermoplastic	
Interfacial Seal	Elastomer	
Alignment Sleeves	Composite Polymer	

Six Port (4+2) Viking Series D38999,
10/100Base-TX / FX Unmanaged Ethernet Switch

TRANSMITTERS T_A = Operating Temperature Range

Parameter	Symbol	Minimum	Typical	Maximum	Unit
Optical Output Power	P_o	-19.0		-14.0	dBm
Optical Output Wavelength	λ_{OUT}	1260	1310	1380	nM

RECEIVERS T_A = Operating Temperature Range

Parameter	Symbol	Minimum	Typical	Maximum	Unit
Optical Sensitivity	P_i	-31.5		-12.0	dBm
Optical Wavelength	λ_{IN}	1100		1590	nM

SUPPLY CURRENT T_A = Operating Temperature Range

Parameter	Symbol	Minimum	Typical	Maximum	Unit
Supply Current	I_{CCT}		250	275	mA

OPTICAL FIBER LINK DISTANCES

Application	Fiber Specification	Distance
Fast Ethernet - IEEE 802.3u	62.5/125 μ - 500MHz*Km	2.0Km
FDDI PMD ISO / IEC 9314-3	50/125 μ - 500MHz*Km	2.0Km

COPPER CABLE LINK DISTANCES

Application	Cable Specification	Distance
Fast Ethernet - IEEE 802.3u	TIA/EIA-568-B Cat 5*	100M

*for other transmission media, please consult the factory

Six Port (4+2) Viking Series D38999,
10/100Base-TX / FX Unmanaged Ethernet Switch

OUTLINE DRAWING

Dimensions are shown as: inches (mm)

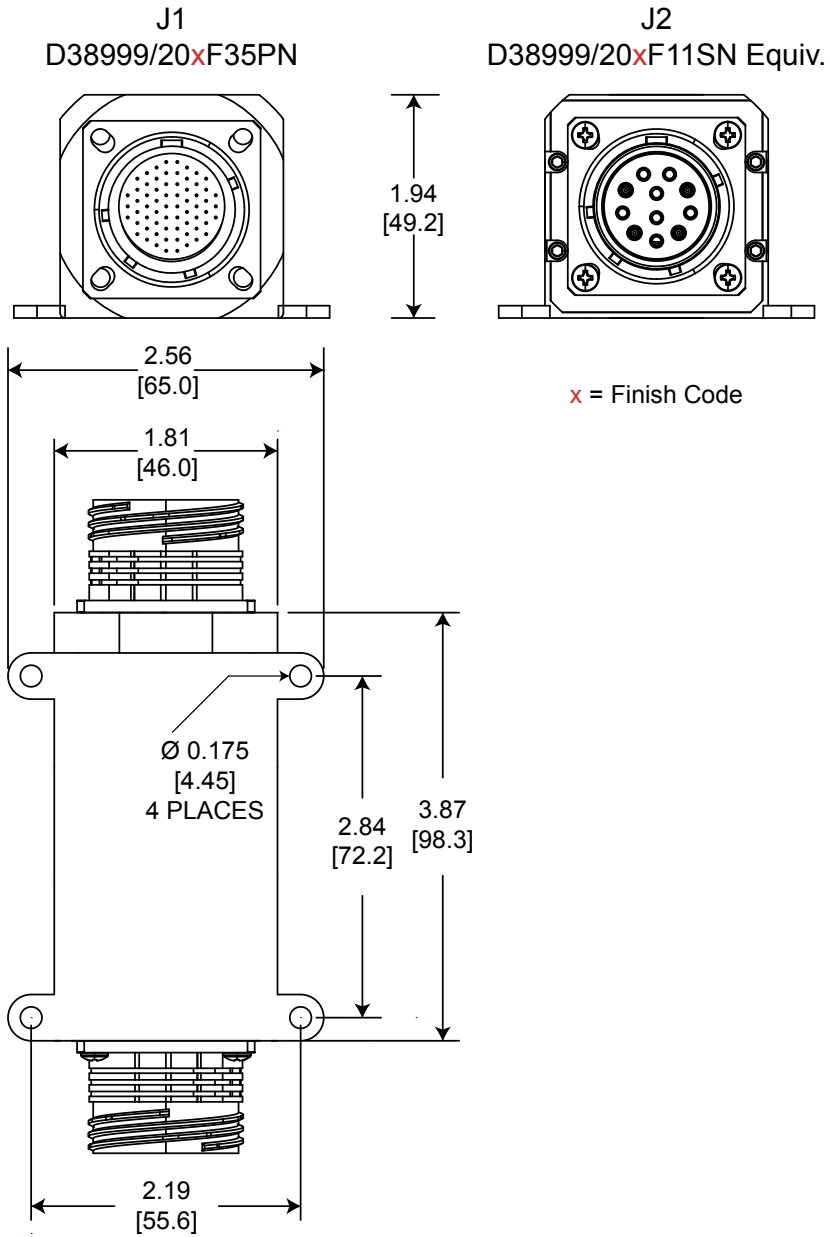

PORT / FUNCTION ASSIGNMENTS

Port #	Function
J1	4x10/100/1000Base-T + 28VDC
J2	2x1000Base-SX or 100Base-FX

Six Port (4+2) Viking Series D38999,
10/100Base-TX / FX Unmanaged Ethernet Switch

J1 PIN FUNCTIONS
ETHERNET PORT AND PIN ASSIGNMENTS

TOP

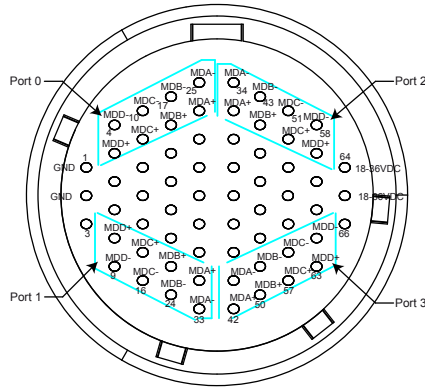

Front view of the J1 connector shown
- mating cable plug opposite - see J1 D38999 Pin
Function Chart for details

PORT #	PIN #	FUNCTION	PORT #	PIN #	FUNCTION
0	26	TXD+	2	35	TXD+
	25	TXD-		34	TXD-
	18	RXD+		44	RXD+
	17	RXD-		43	RXD-
1	32	TXD+	3	42	TXD+
	33	TXD-		41	TXD-
	23	RXD+		50	RXD+
	24	RXD-		49	RXD-

Six Port (4+2) Viking Series D38999,
10/100Base-TX / FX Unmanaged Ethernet Switch

J1 / D38999/20xF35PN ELECTRICAL PIN FUNCTIONS - Continued on next page

Pin #	Port #	Function	RJ-45 Eq. Pin #	Logic Family
1	N/A	GND	N/A	Isolated from Case GND
2	N/A	GND	N/A	Isolated from Case GND
3	N/A	N/C	N/A	Do Not Connect - Factory Use Only
4	N/A	N/C	N/A	Do Not Connect - Factory Use Only
5	N/A	N/C	N/A	Do Not Connect - Factory Use Only
6	N/A	N/C	N/A	Do Not Connect - Factory Use Only
7	N/A	N/C	N/A	Do Not Connect - Factory Use Only
8	N/A	N/C	N/A	Do Not Connect - Factory Use Only
9	N/A	N/C	N/A	Do Not Connect - Factory Use Only
10	N/A	N/C	N/A	Do Not Connect - Factory Use Only
11	N/A	N/C	N/A	Do Not Connect - Factory Use Only
12	N/A	N/C	N/A	Do Not Connect - Factory Use Only
13	N/A	N/C	N/A	Do Not Connect - Factory Use Only
14	N/A	N/C	N/A	Do Not Connect - Factory Use Only
15	N/A	N/C	N/A	Do Not Connect - Factory Use Only
16	N/A	N/C	N/A	Do Not Connect - Factory Use Only
17	0	RXD-	6	IEEE-802.3.2005 10/100Base-TX
18	0	RXD+	3	IEEE-802.3.2005 10/100Base-TX
19	N/A	N/C	N/A	Do Not Connect - Factory Use Only
20	N/A	N/C	N/A	Do Not Connect - Factory Use Only
21	N/A	N/C	N/A	Do Not Connect - Factory Use Only
22	N/A	N/C	N/A	Do Not Connect - Factory Use Only
23	1	RXD-	6	IEEE-802.3.2005 10/100Base-TX
24	1	RXD+	3	IEEE-802.3.2005 10/100Base-TX
25	0	TXD-	2	IEEE-802.3.2005 10/100Base-TX
26	0	TXD+	1	IEEE-802.3.2005 10/100Base-TX Do
27	N/A	N/C	N/A	Not Connect - Factory Use Only Do
28	N/A	N/C	N/A	Not Connect - Factory Use Only Do
29	N/A	N/C	N/A	Not Connect - Factory Use Only Do
30	N/A	N/C	N/A	Not Connect - Factory Use Only Do
31	N/A	N/C	N/A	Not Connect - Factory Use Only
32	1	TXD+	1	IEEE-802.3.2005 10/100Base-TX
33	1	TXD-	2	IEEE-802.3.2005 10/100Base-TX
34	2	TXD-	2	IEEE-802.3.2005 10/100Base-TX

Six Port (4+2) Viking Series D38999,
10/100Base-TX / FX Unmanaged Ethernet Switch

J1 / D38999/20xF35PN ELECTRICAL PIN FUNCTIONS - Continued from previous page

Pin #	Port #	Function	RJ-45 Eq. Pin #	Logic Family
35	2	TXD+	1	IEEE-802.3.2005 10/100Base-TX
36	N/A	N/C	N/A	Do Not Connect - Factory Use Only
37	N/A	N/C	N/A	Do Not Connect - Factory Use Only
38	N/A	N/C	N/A	Do Not Connect - Factory Use Only
39	N/A	N/C	N/A	Do Not Connect - Factory Use Only
40	N/A	N/C	N/A	Do Not Connect - Factory Use Only
41	3	TXD-	2	IEEE-802.3.2005 10/100Base-TX
42	3	TXD+	1	IEEE-802.3.2005 10/100Base-TX
43	2	RXD-	6	IEEE-802.3.2005 10/100Base-TX
44	2	RXD+	3	IEEE-802.3.2005 10/100Base-TX
45	N/A	N/C	N/A	Do Not Connect - Factory Use Only
46	N/A	N/C	N/A	Do Not Connect - Factory Use Only
47	N/A	N/C	N/A	Do Not Connect - Factory Use Only
48	N/A	N/C	N/A	Do Not Connect - Factory Use Only
49	3	RXD-	6	IEEE-802.3.2005 10/100Base-TX
50	3	RXD+	3	IEEE-802.3.2005 10/100Base-TX
51	N/A	N/C	N/A	Do Not Connect - Factory Use Only
52	N/A	N/C	N/A	Do Not Connect - Factory Use Only
53	N/A	N/C	N/A	Do Not Connect - Factory Use Only
54	N/A	N/C	N/A	Do Not Connect - Factory Use Only
55	N/A	N/C	N/A	Do Not Connect - Factory Use Only
56	N/A	N/C	N/A	Do Not Connect - Factory Use Only
57	N/A	N/C	N/A	Do Not Connect - Factory Use Only
58	N/A	N/C	N/A	Do Not Connect - Factory Use Only
59	N/A	N/C	N/A	Do Not Connect - Factory Use Only
60	N/A	N/C	N/A	Do Not Connect - Factory Use Only
61	N/A	N/C	N/A	Do Not Connect - Factory Use Only
62	N/A	N/C	N/A	Do Not Connect - Factory Use Only
63	N/A	N/C	N/A	Do Not Connect - Factory Use Only
64	ALL	V _{cc}	N/A	18-36VDC
65	ALL	V _{cc}	N/A	18-36VDC
66	N/A	N/C	N/A	Do Not Connect - Factory Use Only

Six Port (4+2) Viking Series D38999,
10/100Base-TX / FX Unmanaged Ethernet Switch

J2 PIN FUNCTIONS ETHERNET PORT AND PIN ASSIGNMENTS TOP

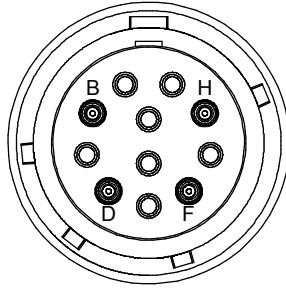

Front view of the D38999 optical
insert shown, fiber optic cable plug
opposite - see Appendix A1 for details

MIL-DTL-38999 OPTICAL INTERFACE

PORT NUMBER	TX	RX
4	H	F
5	B	D

Six Port (4+2) Viking Series D38999,
10/100Base-TX / FX Unmanaged Ethernet Switch

APPENDIX A1

MIL-DTL-38999 FIBER OPTIC CABLE PLUG / MIL-T-29504 PIN TERMINI

*See DSCC or SAE QPL for Approved Suppliers

<http://www.dscclia.mil/programs/qmlqpl/QPLdetail.asp?QPL=38999>

*D38999 PLUG - PIN INSERT

MIL-DTL-38999 CABLE PLUG

MS PLUG P/N

*D38999/26WF11PN

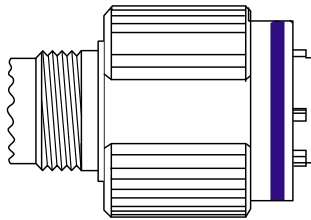

*FIBER OPTIC PIN TERMINUS

MIL-T-29504 PIN TERMINUS

MS PIN TERMINUS P/N

*M29504/04-xxxx**

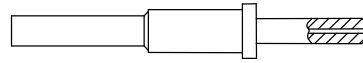

**defined by fiber optic cable configuration

*CABLE PROTECTION CAP

D38999/32 PLUG PROTECTION CAP

MS PLUG CAP P/N

*D38999/32W19N

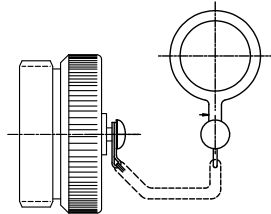

*CABLE BACKSHELL

MIL-C-85049 CABLE BACKSHELL

MS BACKSHELL P/N

*MS85049/xxxxxx**

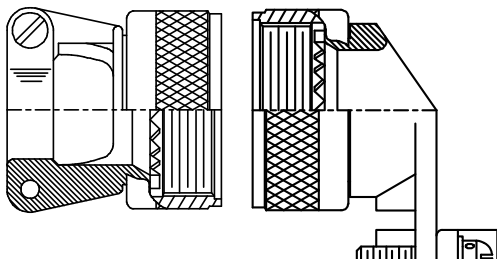

D38999 PLUG PORT FUNCTIONS

PORT NUMBER	TX	RX
4	H	F
5	B	D

TOP
Optical Cable Plug Interface

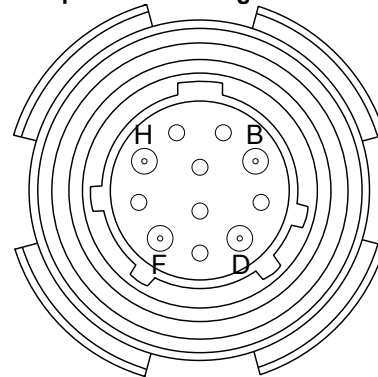

Front face of the optical cable plug pin insert shown. Transceiver insert opposite.

Pin Termini

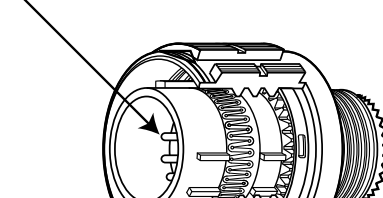

Six Port (4+2) Viking Series D38999,
10/100Base-TX / FX Unmanaged Ethernet Switch

APPENDIX A2

PART NUMBER OPTIONS

In-Line, Six (4+2) Port, 10/100Base-TX / FX, Unmanaged Ethernet Switch

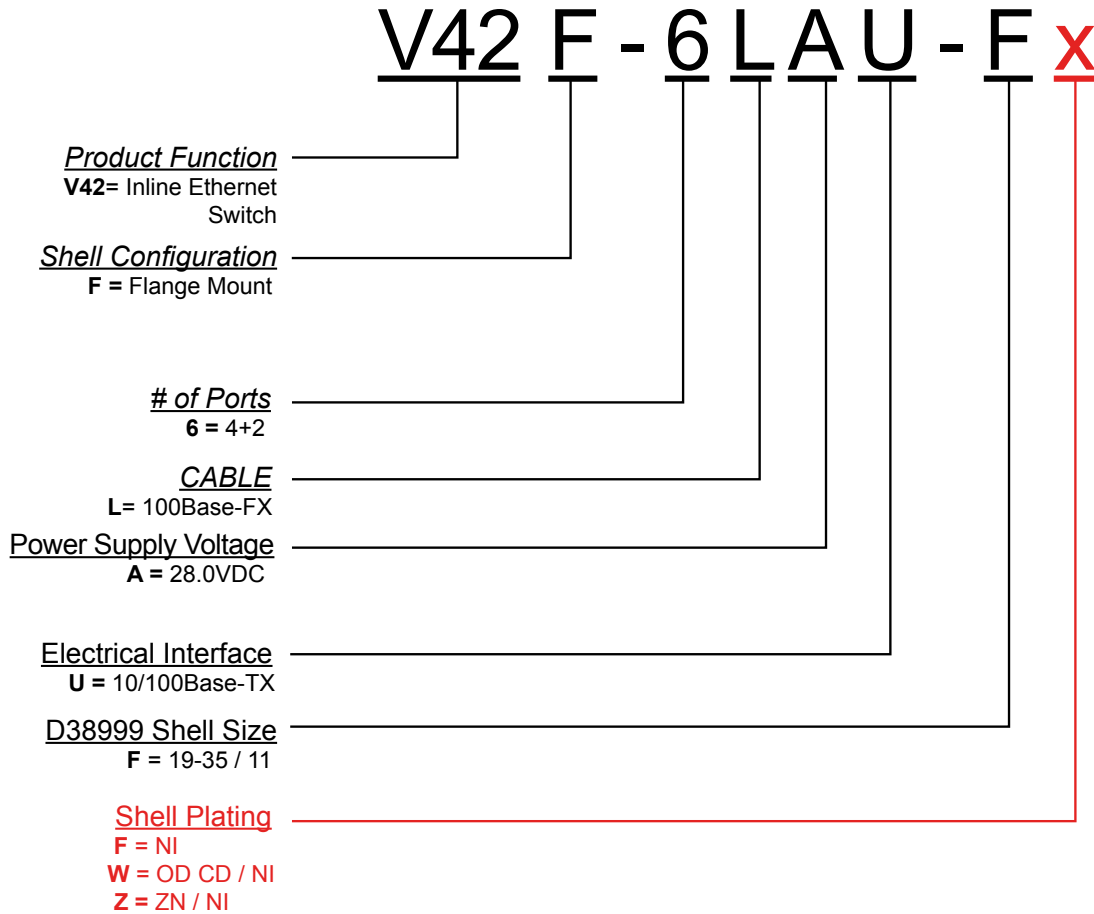

192 Bob Fitz Road, Johnson City, TN 37615
salesmp@moog.com
moogprotokraft.com

Product and company names listed are trademarks or trade names of their respective companies.

© 2019 Moog, Inc. All rights reserved.

V42F-6LAU-FW-DS - Form DS565, Rev. B
October 20, 2017 - Released