

LIGHTNING SERIES

6 TX + 2 RX, MIL-DTL-38999 OPTICAL TRANSCEIVER, FC, ETHERNET AND sFPDP APPLICATIONS, OPERATION TO 10.3125 GBPS, MULTIMODE, 850 NM VCSELS

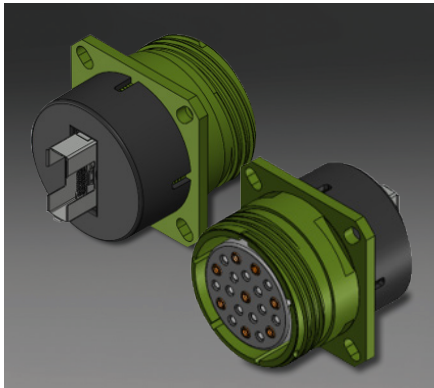

Lightning series optical fiber transceivers consist of optoelectronic transmitter and receiver functions integrated into a bulkhead mounted MIL-DTL-38999 series III receptacle connector. The optical transmitters are 850 nm VCSEL lasers. Differential CML signals drive transmitter input (TX+, TX-) lines. Dual loop, temperature compensated, VCSEL drivers convert the transmitter input signals to suitable VCSEL bias and modulation currents. The TX_Fault circuit disables the optical transmitter output when the optical output power or internal current exceeds predefined limits. A CMOS fault signal is generated on the TX_Fault line upon a transmitter optical or electrical fault condition. The fault signals are latched until reset by a toggle of TX_Dis or V_{cc} .

The optical receivers consist of PIN and preamplifier assemblies and limiting post-amplifiers. Receiver outputs (RX+ and RX- lines) are differential CML data signals with single-ended CMOS indicator functions on the Loss of Signal (LOS) lines. The receiver data lines are squelched upon LOS assertion, preventing errant data generation when an invalid incoming optical signal is presented to the transceiver. The electrical interface to the Lightning series optical transceivers is a high density ARF6 with rugged metal latching and shielding, allowing connection to a rigid or flexible PCB or ARC6 style ribbon cable.

Lightning series optical fiber transceivers are vibration isolated, environmentally hardened components ready for use in harsh environment applications.

6 TX + 2 RX LIGHTNING SERIES MIL-DTL-38999 OPTICAL TRANSCEIVER, MULTIMODE, 850 NM, VCSELs, OPERATION TO 10.3125 GBPS

Six TX and Two RX Channel Operating from 125 Mbps to 10.3125 Gbps
Quad Port, Flange or Jam Nut Receptacle

FEATURES

- Suitable for Ethernet, Fibre Channel and sFPDP applications from 125 Mbps to 10.3125 Gbps
- Optical fiber link distances up to 82 meters (50 / 125µ 500 MHz*Km MMF)
- Maximum optical channel bit error rate less than 1×10^{-12}
- Operating temperature range from -40° to +85°C
- Shock and vibration resistant per MIL-STD-810 and MIL-STD-1344
- Olive drab cadmium over electroless nickel plating meets stringent EMI / RFI performance requirements
- Aluminum alloy MIL-DTL-38999 housings are strong, durable, corrosion resistant and light weight
- MIL-T-29504 compliant optical fiber connector interface
- Connector insert configuration conforms to MIL-STD-1560

APPLICATIONS

Lightning series bulkhead mounted optical transceivers enable high speed network communications over long distances in harsh environments.

- Ethernet switches and peripherals
- Fibre Channel switches and peripherals
- sFPDP data links
- Video displays

The MIL-DTL-38999, series III shell provides a sealed optical interface that is water-tight to MIL-STD-810 / IP67 / NEMA-4x when mated.

The multimode optical fiber interface supports applications where copper cable link distance, bandwidth, weight or bulk make the use of twisted pair, twinax or quadax copper conductors unacceptable.

ORDERING INFORMATION

Application	Part Number
Operation up to 10.3125 Gbps	P38x-621H-Hx

6 TX + 2 RX LIGHTNING SERIES MIL-DTL-38999 OPTICAL TRANSCEIVER, MULTIMODE, 850 NM, VCSELs, OPERATION TO 10.3125 GBPS

ABSOLUTE MAXIMUM RATINGS

Absolute maximum limits mean that no catastrophic damage will occur if the product is subjected to these ratings for short periods, provided each limiting parameter is in isolation and all other parameters have values within the performance specification. It should not be assumed that limiting values of more than one parameter can be applied to the product at the same time.

Parameter	Symbol	Minimum	Typical	Maximum	Unit
Storage Temperature	T_s	-55		+100	°C
Supply Voltage	V_{CC}	-0.5		+4.5	V
Data Input Voltage	V_I	-0.5		$V_{CC} + 0.5$	V
Differential Input Voltage (p-p)	V_D			2.2	V
RX Output Current	I_O			50	mA

RECOMMENDED OPERATING CONDITIONS

Parameter	Symbol	Minimum	Typical	Maximum	Unit
Operating Temperature	T_A	-40		+85	°C
Supply Voltage	V_{CC}	+3.135		+3.465	V
TX Common Mode Voltage	V_{CM}		2.0		V
TX Differential Input Voltage (p-p)	V_D	0.25		2.2	V
Power Supply Noise (p-p)	N_P			200	mA

DESIGNED TO SPECIFICATION COMPLIANCE

Requirement	Description	Section
MIL-STD-461	Conducted Emissions	CE102
MIL-STD-461	Conducted Susceptibility	CS101, CS114 - 116
MIL-STD-461	Radiated Emissions	RE102
MIL-STD-461	Radiated susceptibility	RS103
MIL-STD-810	High / Low Temp Opp	M 501.6 / 502.6 P II
MIL-STD-810	High / Low Temp Storage	M 502.6 / 502.6 P I
MIL-STD-810	Altitude Opp / Non-Opp	M 500 P I, 15 k Feet
MIL-STD-810	Humidity	M 507, P II
MIL-STD-810	Acoustic Noise	M 515.7 P I
MIL-STD-810	Shock	> 100 G
MIL-STD-810	Vibration	M 514
MIL-STD-810	Sea Salt Atmosphere	M 509
MIL-STD-810	Fungus	M 508.6
MIL-STD-1686	ESD	Class 1

MATERIALS

Item	Detail	Notes
Shell	Aluminum Alloy	
Shell Plating	Olive Drab Cadmium Over Nickel	QQ-P-416, QQ-N-290
Insert	Thermoplastic	
Interfacial Seal	Elastomer	
Alignment Sleeves	Composite Polymer	
Printed Circuits	Polyimide / FR-4	MIL-P-31032 Type 4

6 TX + 2 RX LIGHTNING SERIES MIL-DTL-38999 OPTICAL TRANSCEIVER, MULTIMODE, 850 NM, VCSELs, OPERATION TO 10.3125 GBPS

OPTICAL TRANSMITTERS T_A = OPERATING TEMPERATURE RANGE, V_{CC} = 3.135 V TO 3.465 V

Parameter	Symbol	Minimum	Typical	Maximum	Unit
Optical Output Power (BER $< 10^{-12}$) P38x-621H-xx	P_o	-7.3		-1.0	dBm
Optical Output Wavelength	λ_{OUT}	830	850	850	nM
Extinction Ratio	ER	3.0	5.0		dB

OPTICAL RECEIVERS T_A = OPERATING TEMPERATURE RANGE, V_{CC} = 3.135 V TO 3.465 V

Parameter	Symbol	Minimum	Typical	Maximum	Unit
Optical Sensitivity (BER $< 10^{-12}$, ER = 5.0)	P_i	-11.1		-1.0	dBm
Optical Wavelength	λ_{IN}	770		860	nM

POWER SUPPLY CURRENT T_A = OPERATING TEMPERATURE RANGE, V_{CC} = 3.135 V TO 3.465 V

Parameter	Symbol	Minimum	Typical	Maximum	Unit
Supply Current Per Port	I_{CCT}		110	150	mA

6 TX + 2 RX LIGHTNING SERIES MIL-DTL-38999 OPTICAL TRANSCEIVER, MULTIMODE, 850 NM, VCSELs, OPERATION TO 10.3125 GBPS

OUTLINE DRAWING - FLANGE MOUNT OPTION

Dimensions are shown as: inches (mm)

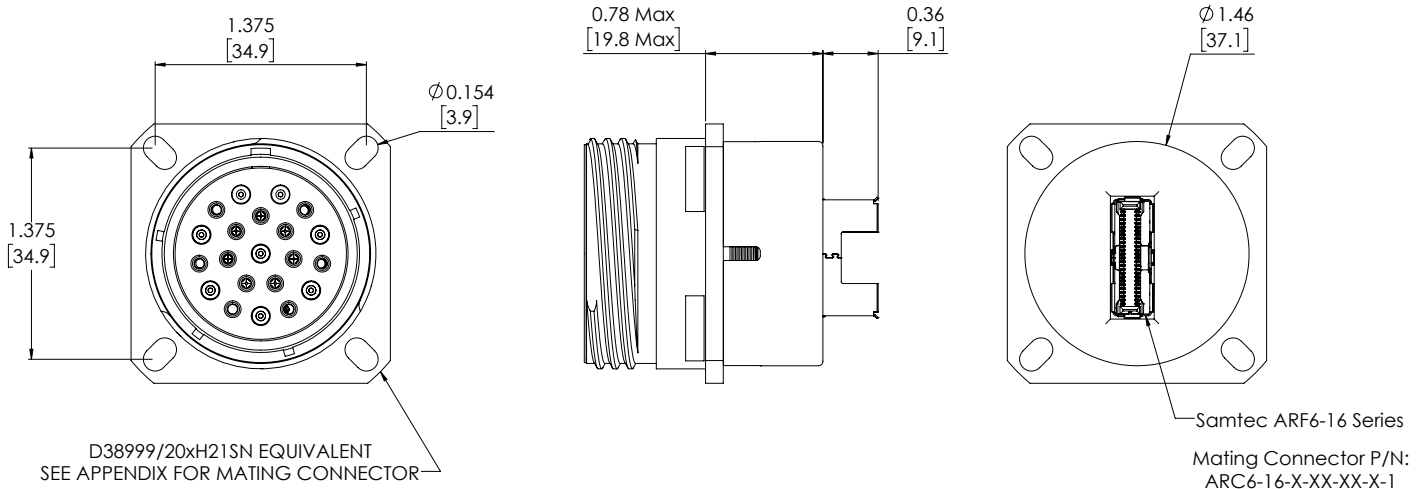

PANEL CUTOUT DIMENSIONS - FLANGE MOUNT

Shell Size Code	Shell Size	M Min.	P Holes	R Bsc
H	23	1.547 [39.29]	0.159 [4.0] / 0.149 [3.8]	1.375 [34.9]

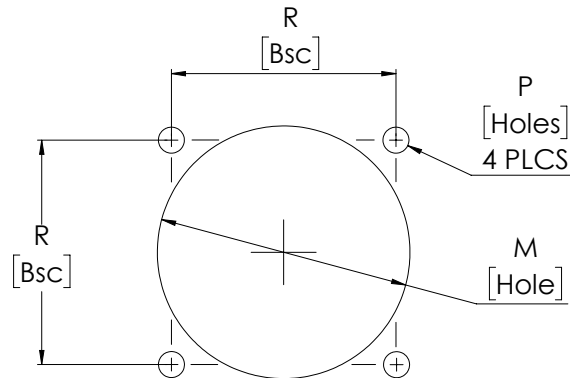

Part Number = *P38F-621H-Hxx

*See Appendix 2 for complete ordering options

6 TX + 2 RX LIGHTNING SERIES MIL-DTL-38999 OPTICAL TRANSCEIVER, MULTIMODE, 850 NM, VCSELs, OPERATION TO 10.3125 GBPS

OUTLINE DRAWING - JAM NUT OPTION

Dimensions are shown as: inches (mm)

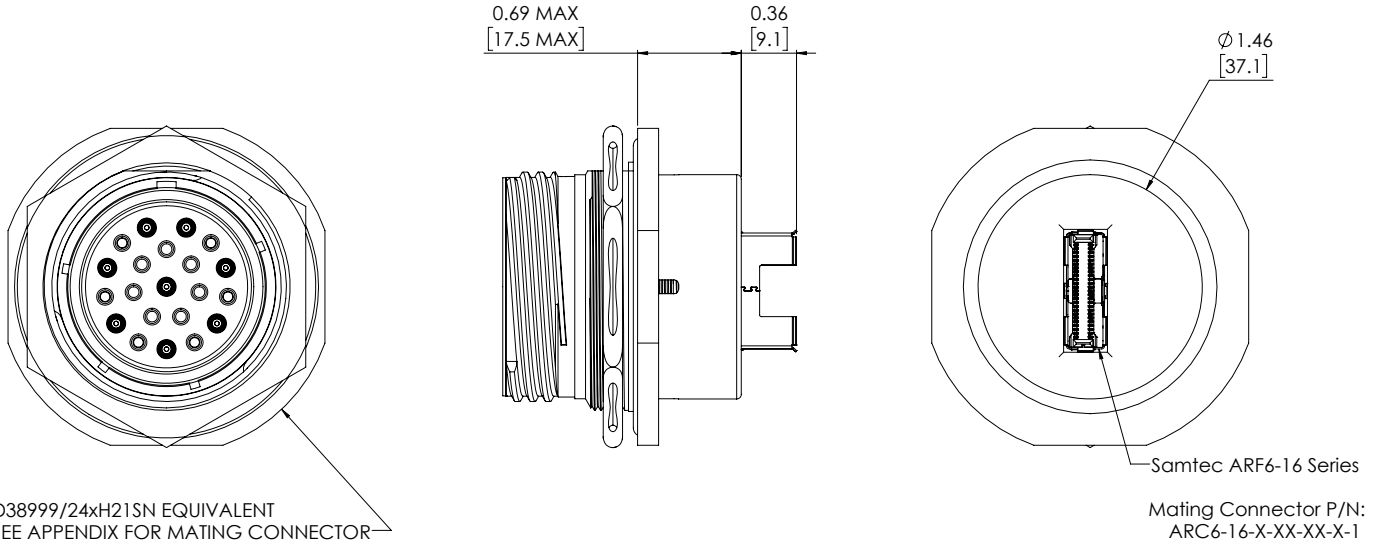

PANEL CUTOUT DIMENSIONS - FLANGE MOUNT

Shell Size Code	Shell Size	D1 Min.	D2 Min.
H	23	1.635 [41.53]	1.585 [40.26]

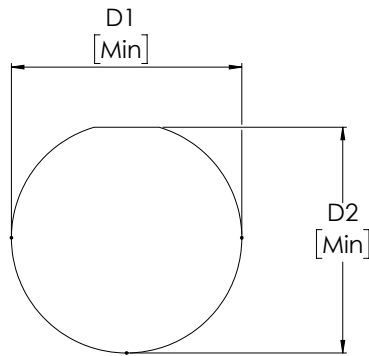

Part Number = *P38J-621H-Hxx

*See Appendix 2 for complete ordering options

6 TX + 2 RX LIGHTNING SERIES MIL-DTL-38999 OPTICAL TRANSCEIVER, MULTIMODE, 850 NM, VCSELs, OPERATION TO 10.3125 GBPS

J1 D38999 PIN AND PORT ASSIGNMENTS

TOP
Optical Interface

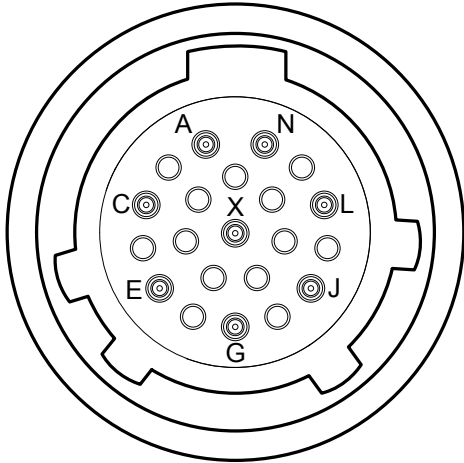

Front view of the D38999 optical insert shown, fiber optic cable plug opposite - see Appendix A1 for details.

OPTICAL TRANSCEIVER RECEPTACLE PORT ASSIGNMENTS

Function Port Number	Optical		Electrical	
	TX	RX	TX (-, +)	RX (-, +)
0	J	L	17, 15	35, 33
1	N	A	39, 41	40, 42
2	X		16, 18	
3	E		4, 6	
4	C		34, 36	
5	G		3, 5	

6 TX + 2 RX LIGHTNING SERIES MIL-DTL-38999 OPTICAL TRANSCEIVER, MULTIMODE, 850 NM, VCSELs, OPERATION TO 10.3125 GBPS

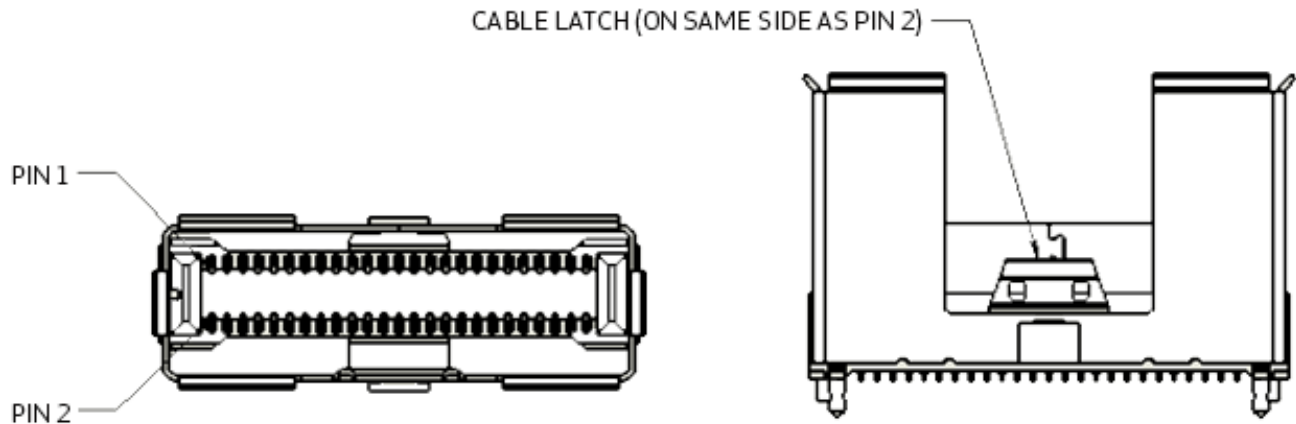

ELECTRICAL PIN ASSIGNMENTS

MIL-DTL-38999 SERIES III, SIZE 15-5

Electrical Pin	Function	Logic Family	Port Number	Optical Pin Number	Function
1	Gnd	NA	ALL	ALL	NA
2	Gnd	NA	ALL	ALL	NA
3	TX-	CML	5	G	TX
4	TX-	CML	3	E	TX
5	TX+	CML	5	G	TX
6	TX+	CML	3	E	TX
7	Gnd	NA	ALL	ALL	NA
8	Gnd	NA	ALL	ALL	NA
9	LOS	CMOS	A,L	A,L	RX
10	FLT	CMOS	C,E,G,J,N,X	C,E,G,J,N,X	TX
11	TX_DIS	CMOS	4	C	TX
12	TX_DIS	CMOS	5	G	TX
13	Gnd	NA	ALL	ALL	NA
14	Gnd	NA	ALL	ALL	NA
15	TX+	CML	0	J	TX
16	TX-	CML	2	X	TX
17	TX-	CML	0	J	TX
18	TX+	CML	2	X	TX
19	Gnd	NA	ALL	ALL	NA
20	Gnd	NA	ALL	ALL	NA
21	Vcc	NA	ALL	ALL	NA
22	Vcc	NA	ALL	ALL	NA
23	Vcc	NA	ALL	ALL	NA
24	Vcc	NA	ALL	ALL	NA
25	Gnd	NA	ALL	ALL	NA
26	Gnd	NA	ALL	ALL	NA
27	Vcc	NA	ALL	ALL	NA

6 TX + 2 RX LIGHTNING SERIES MIL-DTL-38999 OPTICAL TRANSCEIVER, MULTIMODE, 850 NM, VCSELs, OPERATION TO 10.3125 GBPS

ELECTRICAL PIN ASSIGNMENTS

MIL-DTL-38999 SERIES III, SIZE 15-5

Electrical		Port Number		Optical	
Pin	Function	Logic Family		Pin Number	Function
28	Vcc	NA	ALL	ALL	NA
29	Vcc	NA	ALL	ALL	NA
30	Vcc	NA	ALL	ALL	NA
31	Gnd	NA	ALL	ALL	NA
32	Gnd	NA	ALL	ALL	NA
33	RX+	CML	0	L	RX
34	TX-	CML	4	C	TX
35	RX-	CML	0	L	RX
36	TX+	CML	4	C	TX
37	Gnd	NA	ALL	ALL	NA
38	Gnd	NA	ALL	ALL	NA
39	TX-	CML	1	N	TX
40	RX-	CML	1	A	RX
41	TX+	CML	1	N	TX
42	RX+	CML	1	A	RX
43	Gnd	NA	ALL	ALL	NA
44	Gnd	NA	ALL	ALL	NA
45	TX_DIS	CMOS	3	E	TX
46	TX_DIS	CMOS	0	J	TX
47	TX_DIS	CMOS	2	X	TX
48	TX_DIS	CMOS	1	N	TX
49	Gnd	NA	ALL	ALL	NA
50	Gnd	NA	ALL	ALL	NA

6 TX + 2 RX LIGHTNING SERIES MIL-DTL-38999 OPTICAL TRANSCEIVER, MULTIMODE, 850 NM, VCSELs, OPERATION TO 10.3125 GBPS

APPLICATION SCHEMATIC

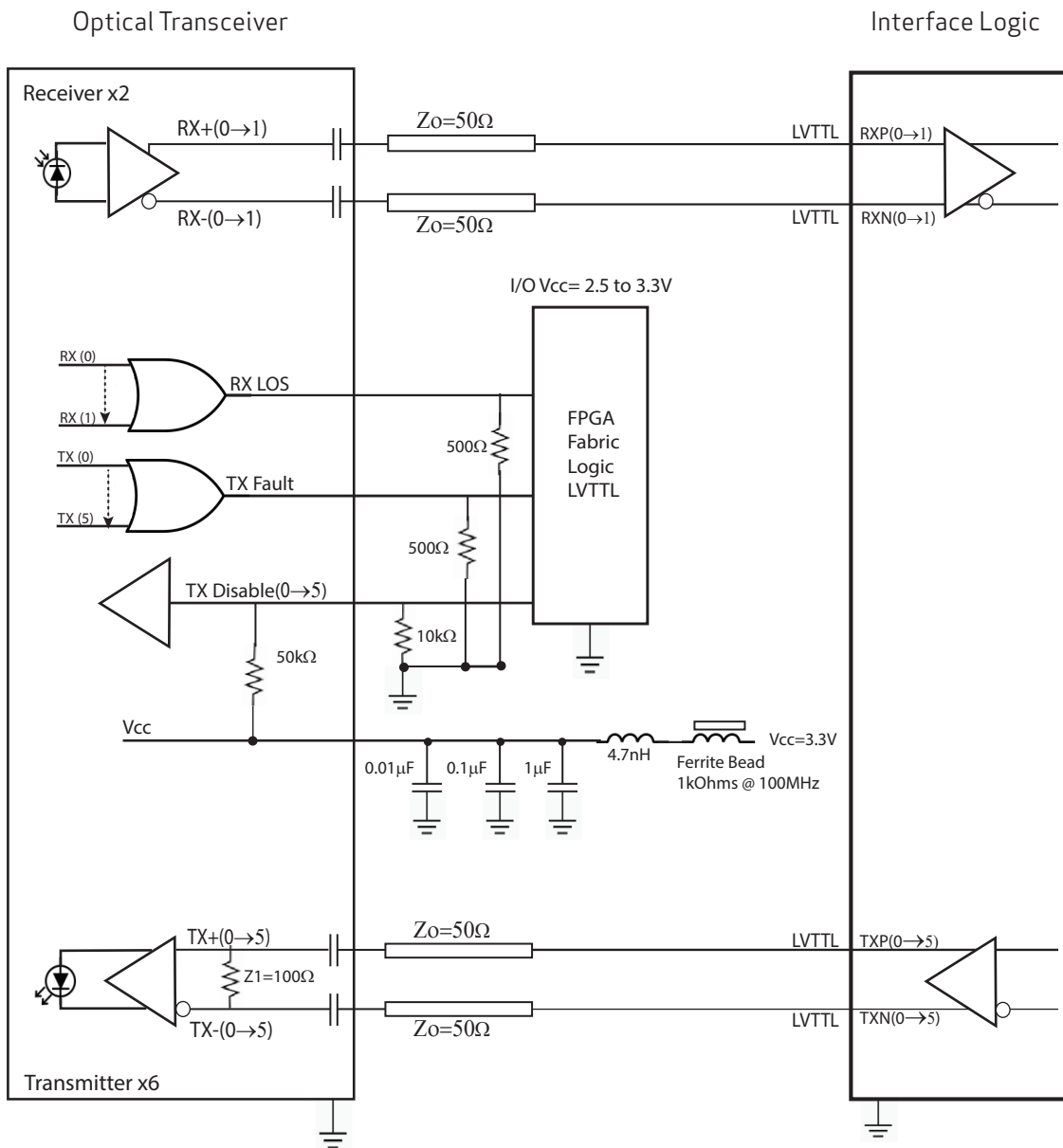

Typical application schematic shown. For alternate applications or termination techniques, please consult the factory.

Note: 50 Ohm impedance termination shown. For other impedance requirements, please consult the factory.

All Protokraft statements, technical information and recommendations related to the products herein are based upon information believed to be reliable or accurate. However, the accuracy or completeness thereof is not guaranteed, and Protokraft assumes no responsibility for any inaccuracies. The user assumes all risks and liability whatsoever in connection with the use of a product or its application. Protokraft reserves the right to change at any time, without prior or subsequent notice, the design, specifications, function, fit or form of its products described herein, including withdrawal at any time of a product offered for sale herein. Protokraft makes no representations that the products herein are free from any intellectual property claims of others. Protokraft and the Protokraft logo are trademarks of Protokraft, LLC. Other trademarks are the property of their respective holders. Contact Protokraft for prices and availability. For the most recent version of this data sheet, please go to the Protokraft website at www.protokraft.com. In case of discrepancy, the web version takes precedence over any printed literature.

6 TX + 2 RX LIGHTNING SERIES MIL-DTL-38999 OPTICAL TRANSCEIVER, MULTIMODE, 850 NM, VCSELs, OPERATION TO 10.3125 GBPS

APPENDIX A1 MIL-DTL-38999 FIBER OPTIC CABLE PLUG / MIL-T-29504 PIN TERMINI

*See DSCC or SAE QPL for Approved Suppliers
<http://www.dsccl.dla.mil/programs/qmlqpl/QPLdetail.asp?QPL=38999>

*D38999 PLUG - PIN INSERT MIL-DTL-38999 CABLE PLUG

MS Plug P/N *D38999 / 26WH21PN

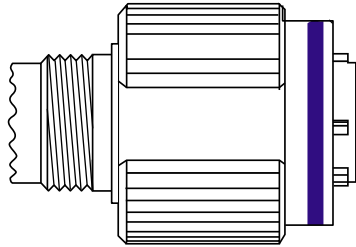

*CABLE PROTECTION CAP D38999 / 32 PLUG PROTECTION CAP

MS Plug Cap P/N *D38999 / 32W23N

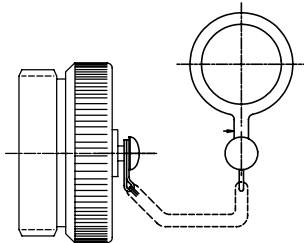

*CABLE BACKSHELL MIL-C-85049 CABLE BACKSHELL

MS Backshell P/N *MS85049 / XXXXXX**

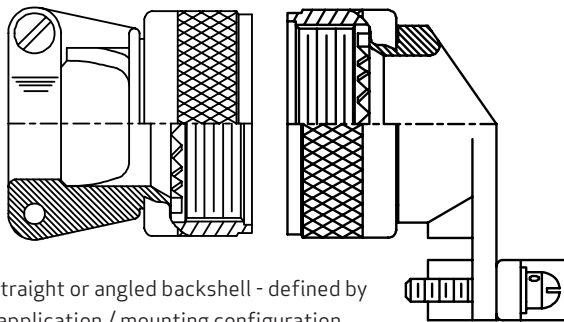

**Straight or angled backshell - defined by application / mounting configuration

*FIBER OPTIC PIN TERMINUS MIL-T-29504 PIN TERMINUS

MS Pin Terminus P/N *MS29504 / 04-xxxx**

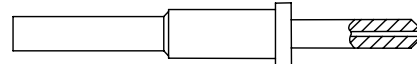

**Defined by fiber optic cable configuration

D38999 PLUG PORT FUNCTIONS

Port Number	TX	RX
0	J	L
1	N	A
2	X	
3	E	
4	C	
5	G	

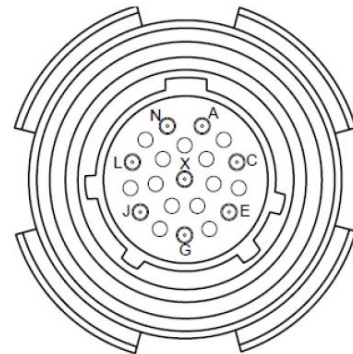

Front face of the optical cable plug pin insert shown. Transceiver insert opposite.

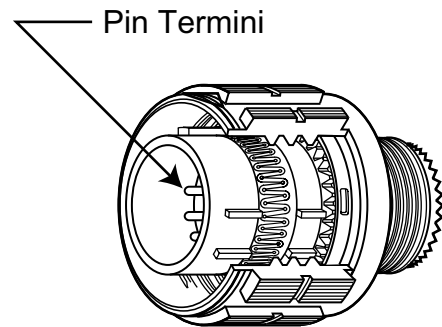

6 TX + 2 RX LIGHTNING SERIES MIL-DTL-38999 OPTICAL TRANSCEIVER, MULTIMODE, 850 NM, VCSELs, OPERATION TO 10.3125 GBPS

APPENDIX A3 PART NUMBER OPTIONS

QUAD PORT, SQUARE FLANGE AND JAM NUT, VCSEL

P38 **x** - **62** **x** **H** - **H** **x** **x**

- SHELL CONFIGURATION
P38 = 38999 Receptacle
- SHELL CONFIGURATION
F = Square Flange
J = Jam Nut
- # CHANNELS (TX + RX)
62 = 6 TX + 2 RX
- CABLE MODE
1 = Multimode
- FIBER OPTIC INTERFACE
H = 125 Mbps - 10.3125 Gbps
- SHELL SIZE CODE
H = 23 - 21
- SHELL PLATING
F = NI
W = OD CD / NI
Z = ZN / NI
- POLARIZATION
(Leave blank) **_** = N
A = A
B = B
C = C
D = D



192 Bob Fitz Road, Johnson City, TN 37615
salesmp@moog.com
moogprotokraft.com