

## DIRECT 9 SERIES

ARINC 801 COMPLIANT OPTICAL TRANSCEIVER, 100BASE-FX APPLICATIONS UP TO 200 MBPS, MULTIMODE, 1310 NM

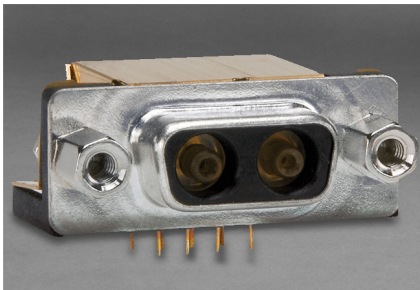

Direct 9 series D-Subminiature optical fiber transceivers consist of optoelectronic transmitter and receiver functions integrated into a printed circuit board mounted D-Subminiature / ARINC 801 compliant receptacle connector. The optical transmitters are 1310 nM light emitting diodes. The transmitter input lines are driven with differential LVPECL signals applied to the transmitter (TX+ and TX-) lines. Temperature compensated, LED drivers convert the transmitter input signals to a suitable modulation current.

The optical receivers consist of PIN and preamplifier assemblies and limiting post-amplifiers. Outputs from the receivers consist of differential LVPECL data signals on the receiver (RX+ and RX-) lines and a single ended LVPECL Signal Detect function on the SD pin.

The receiver data lines are squelched upon Signal Detect deassertion, preventing errant data generation when an invalid incoming optical signal is presented to the transceiver. The optical mating interface to the Direct 9 series D-Subminiature optical fiber transceivers is a DB-9 fiber optic cable plug with ARINC 801 contacts. The electrical interface to the Direct 9 series D-Subminiature optical transceivers is a solder pin field enabling direct substitution for existing electrical 9 position D-Subminiature connectors.

Direct 9 series D-Subminiature optical fiber transceivers are vibration isolated, environmentally hardened components designed for use in harsh environment applications.

# ARINC 801 COMPLIANT OPTICAL TRANSCEIVER, 100BASE-FX APPLICATIONS UP TO 200 MBPS, MULTIMODE, 1310 NM

Duplex Optical Transceiver Unit

## FEATURES

- Compliant with , IEEE-802.3u / 100Base-FX Fast Ethernet, applications up to 200 Mbps
- Optical fiber link distances up to 2.0 Km (62.5/125 $\mu$  500MHz\*Km MMF)
- Maximum optical channel bit error rate less than  $2.5 \times 10^{-10}$
- Operating temperature range from -40°C to +85°C
- Shock and vibration resistant per RTCA / D0-160E
- Electroless nickel plating meets stringent EMI / RFI performance specifications
- D-Subminiature housings are strong, durable, corrosion resistant and light weight
- ARINC 801 compliant optical fiber connector interface
- Threaded mating connectors provide secure interface conditions in high shock and vibration environments

## APPLICATIONS

Direct 9 series printed circuit board mounted optical transceivers enable high speed network communications over long distances in harsh environments.

- Fast Ethernet switches and peripherals
- Telecom and datacom switch / router rack-to-rack links
- Storage or computation clusters

The 9 postion D-Subminiature shell provides a ruggedoptical interface that is compliant with ARINC 801.

The multimode optical fiber interface supports applications where copper cable link distance, bandwidth, weight or bulk make the use of twisted pair, twinax or quadrax copper conductors unacceptable.

### ORDERING INFORMATION

Application	Part Number
100Base-FX Fast Ethernet	P24D-2L1C-EF
Applications up to 200 Mbps	P24D-2L1K-EF

# ARINC 801 COMPLIANT OPTICAL TRANSCEIVER, 100BASE-FX APPLICATIONS UP TO 200 MBPS, MULTIMODE, 1310 NM

## ABSOLUTE MAXIMUM RATINGS

Absolute maximum limits mean that no catastrophic damage will occur if the product is subjected to these ratings for short periods, provided each limiting parameter is in isolation and all other parameters have values within the performance specification. It should not be assumed that limiting values of more than one parameter can be applied to the product at the same time.

Parameter	Symbol	Minimum	Typical	Maximum	Unit
Storage Temperature	$T_s$	-55		+100	°C
Supply Voltage	$V_{CC}$	-0.5		+4.5	V
Data Input Voltage	$V_I$	-0.5		$V_{CC} + 0.5$	V
Differential Input Voltage (p-p)	$V_D$			2.0	V
RX Output Current	$I_o$			50	mA

## RECOMMENDED OPERATING CONDITIONS

Parameter	Symbol	Minimum	Typical	Maximum	Unit
Operating Temperature	$T_A$	-40		+85	°C
Power Supply Voltage	$V_{CC}$	+3.135		+3.465	V
TX Common Mode Voltage	$V_{CM}$		2.0		V
TX Differential Input Voltage (p-p)	$V_D$	0.35		1.25	V
Power Supply Noise (p-p)	$N_p$			200	mV

## DESIGNED TO SPECIFICATIONS COMPLIANCE

Requirement	Feature	Condition	Notes
RTCA / D0-160E	ESD	Class II	2200 V
RTCA / D0-160E	Vibration	3.8 g <sup>2</sup> /Hz	43G rms
RTCA / D0-160E	Shock	40.0 g	6-9 mS
RTCA / D0-160E	Flame Resistance	Method 1012	30 Seconds
RTCA / D0-160E	Damp Heat	10 Cycles	24 Hours
ARINC 801	Mating Durability	500 Cycles	<0.5 dB Change
FDA / CDRH / IEC-825-1	Eye Safety	Class 1	No Safety Interlocks Required

## MATERIALS

Item	Detail	Notes
D-Subminiature Shell	Nickel Plated Steel	
Solder Pins	Brass	
Solder Pin Plating	Gold over Nickel	
Insert	Composite Polymer	
Alignment Sleeves	Thermoplastic	
Printed Circuits	Polyimide / FR-4	

# ARINC 801 COMPLIANT OPTICAL TRANSCEIVER, 100BASE-FX APPLICATIONS UP TO 200 MBPS, MULTIMODE, 1310 NM

## TRANSMITTERS $T_A$ = OPERATING TEMPERATURE RANGE, $V_{CC}$ = 3.135V TO 3.465V

Parameter	Symbol	Minimum	Typical	Maximum	Unit
Optical Output Power <sup>1</sup>	$P_o$	-19		-14.0	dBm
Optical Output Wavelength	$\lambda_{OUT}$	1260	1310	1350	nM
Extinction Ratio	ER	10.0			dB

1. BER=2.5X10<sup>-10</sup>@ 125Mbps, PRBS 2<sup>7</sup>-1, NRZ,  $P_o$  = Power launched into 62.5/125 $\mu$  patch cable - 1.0 meter long

## OPTICAL RECEIVERS $T_A$ = OPERATING TEMPERATURE RANGE, $V_{CC}$ = 3.135V TO 3.465V

Parameter	Symbol	Minimum	Typical	Maximum	Unit
Optical Sensitivity <sup>1</sup>	$P_i$	-31.5		-8.0	dBm
Optical Wavelength	$\lambda_{IN}$	1100		1590	nM
Signal Detect Assert Time	$t_{SDAS}$		<10	100	$\mu$ S
Signal Detect Deassert Time	$t_{SDDA}$		<10	350	$\mu$ S
Signal Detect Threshold Decreasing Light	LSTD	-45.0		-34.5	dBm
Increasing Light	LSTI	-45.0		-34.0	
RX Data Output - Low	$V_{OL} - V_{CC}$	-1.810		-1.475	V
RX Data Output - High	$V_{OH} - V_{CC}$	-1.165		-0.880	V

1. BER=2.5X10<sup>-10</sup>@ 125Mbps, PRBS 2<sup>7</sup>-1, NRZ, Compliant with FDDI PMD ISO / IEC 9314-3 and IEEE-802.3u

## POWER SUPPLY CURRENT $T_A$ = OPERATING TEMPERATURE RANGE, $V_{CC}$ = 3.135V TO 3.465V

Parameter	Symbol	Minimum	Typical	Maximum	Unit
Supply Current	$I_{CCT}$		190	245	mA

# ARINC 801 COMPLIANT OPTICAL TRANSCEIVER, 100BASE-FX APPLICATIONS UP TO 200 MBPS, MULTIMODE, 1310 NM

## OUTLINE DRAWING

Dimensions are shown as: inches [mm]

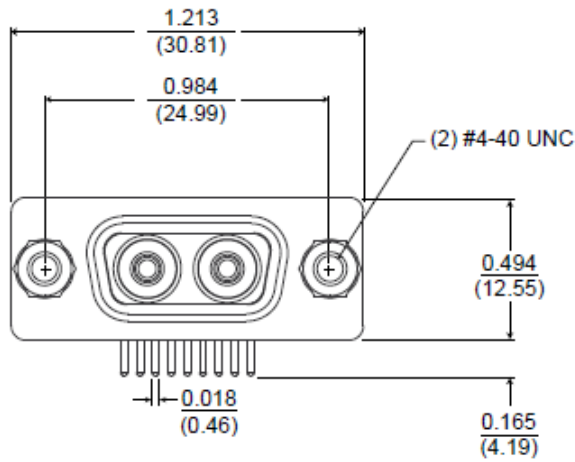

## Recommended PCB Layout Top View - Component Side

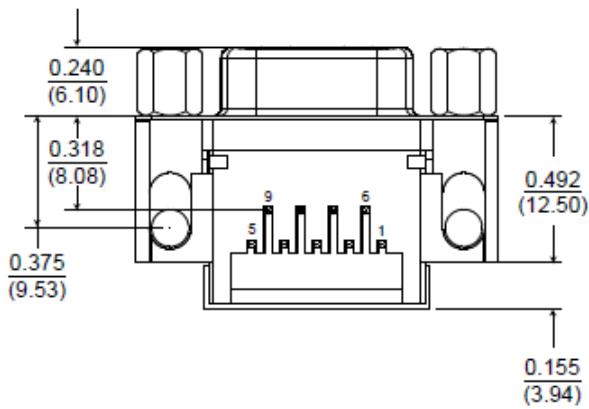
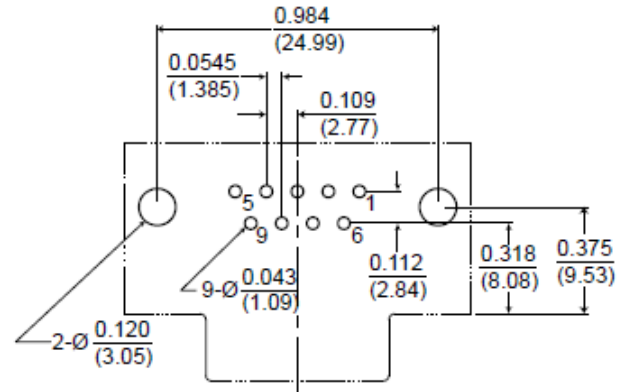

Aqueous washing is permitted with the protective covers in place. If necessary, after washing, clean the optical barrels with lint free swabs and Isopropyl alcohol. The transceivers are conformally coated but after the aqueous washing the units should be baked @ 85°C for 1.0 hour to eliminate any retained moisture.

# ARINC 801 COMPLIANT OPTICAL TRANSCEIVER, 100BASE-FX APPLICATIONS UP TO 200 MBPS, MULTIMODE, 1310 NM

## ELECTRICAL PIN ASSIGNMENTS - D-SUBMINIATURE SHELL SIZE 09

Pin Number	Symbol	Description	Logic Family
1	RX-	Receiver Data - Output	LVPECL
2	RX+	Receiver Data - Output	LVPECL
3	GND	Ground	N/A
4	TX-	Transmitter Data - Input	LVPECL Internal 100Ω differential termination
5	TX+	Transmitter Data - Input	LVPECL Internal 100Ω differential termination
6	V <sub>cc</sub>	Power Supply	N/A
7	SD	Loss of Signal Indicator - Output Satisfactory Operation: Logic "1" Output Optical Fault: Logic "0" Output	LVPECL
8	GND	Ground	N/A
9	GND	Ground	N/A

## INSERT ARRANGEMENT - D-SUBMINIATURE SHELL SIZE 09

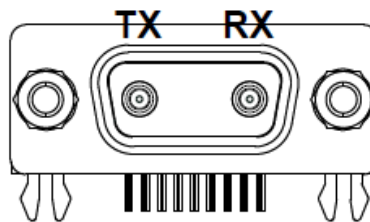

Front face of the transceiver socket insert shown!

Mating cable plug interface opposite.

# ARINC 801 COMPLIANT OPTICAL TRANSCEIVER, 100BASE-FX APPLICATIONS UP TO 200 MBPS, MULTIMODE, 1310 NM

## APPLICATION SCHEMATIC

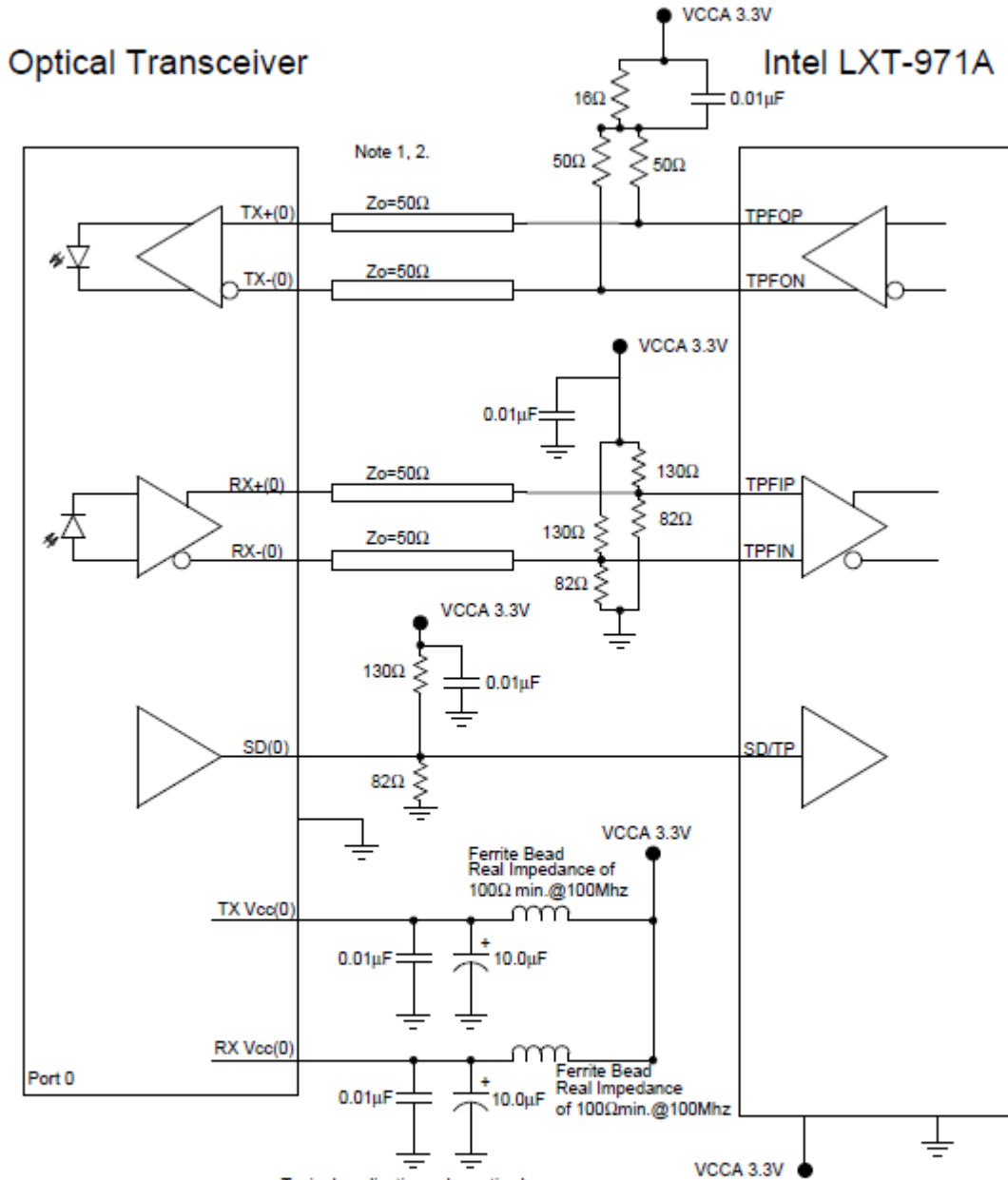

Typical application schematic shown.  
For Alternative applications or termination techniques  
Please consult the Factory

Note: 1  
When using controlled impedance cable (Coaxial cable),  
lengths of >1meter are obtainable.

Note: 2  
50 ohm impedance termination shown.  
For other impedance requirements please consult the factory

# ARINC 801 COMPLIANT OPTICAL TRANSCEIVER, 100BASE-FX APPLICATIONS UP TO 200 MBPS, MULTIMODE, 1310 NM

## APPENDIX A1 Direct 9 Fiber Optic Cable Plug / ARINC 801 Pin Termini

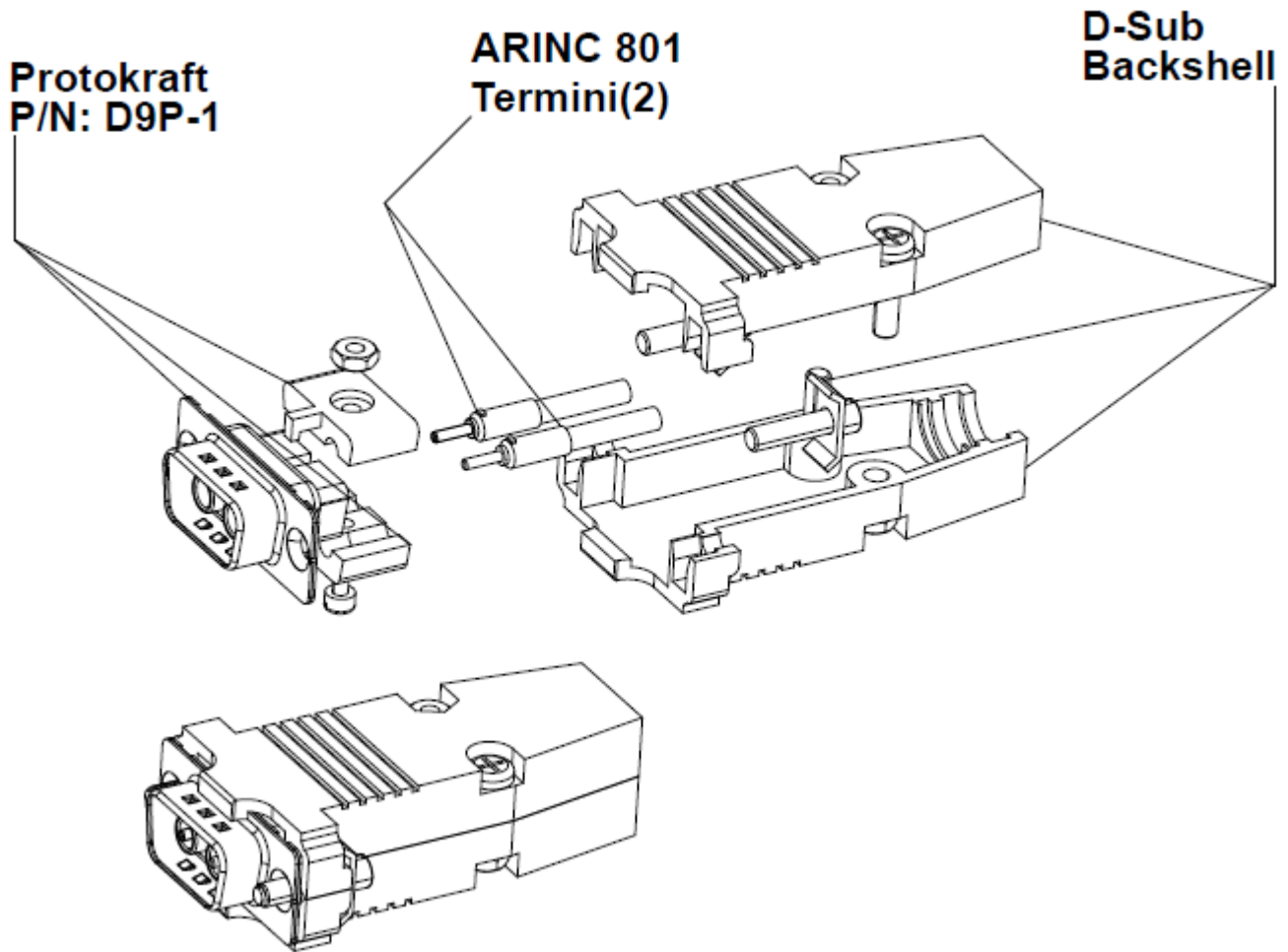

# ARINC 801 COMPLIANT OPTICAL TRANSCEIVER, 100BASE-FX APPLICATIONS UP TO 200 MBPS, MULTIMODE, 1310 NM

## APPENDIX A2 Direct 9 Fiber Optic D-Subminiature Cable Plug Insert

Dimensions are shown as: inches [mm]

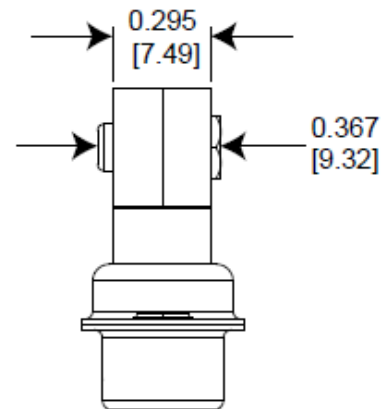
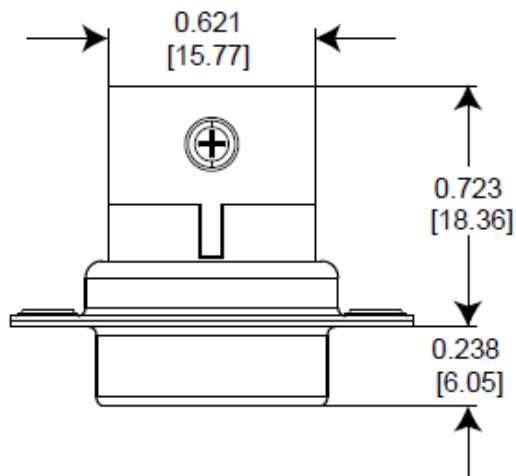
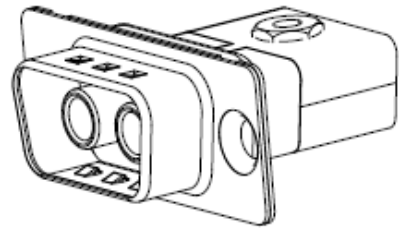
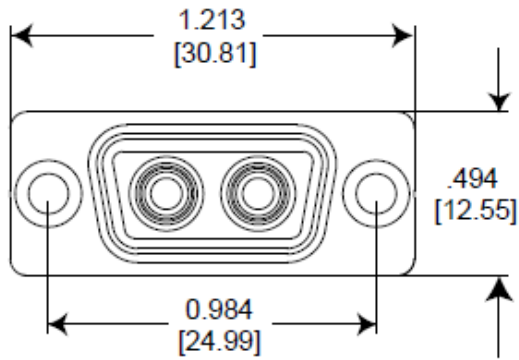

Protokraft Direct 9 Fiber Optic Cable Plug Part Number: D9P-1  
See Appendix A3 for test cable options

# ARINC 801 COMPLIANT OPTICAL TRANSCEIVER, 100BASE-FX APPLICATIONS UP TO 200 MBPS, MULTIMODE, 1310 NM

## APPENDIX A3

### DIRECT 9 FIBER OPTIC D-SUBMINIATURE TEST CABLE OPTIONS

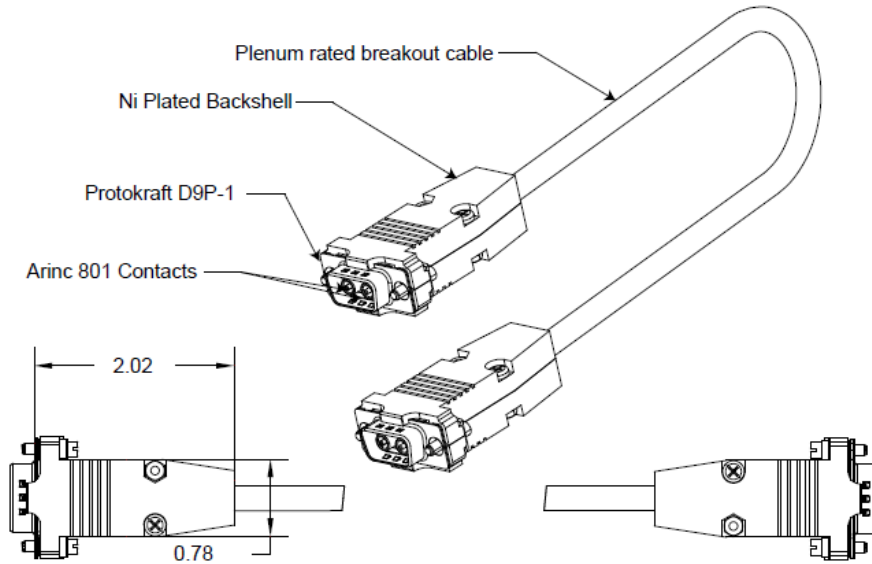

P24C-0121 -1 Shown



### PART NUMBER OPTIONS

# P24C - XX X X - X

01-99 Meters

1 = 50  $\mu\text{m}$

2 = 62.5  $\mu\text{m}$

1 = D9P-1 Straight

2 = D9P-1 Right Angle

1 = D9P-1 Straight

2 = D9P-1 Right Angle

3 = ST

4 = LC

5 = FC

# MOOG

192 Bob Fitz Road, Johnson City, TN 37615  
 salesmp@moog.com  
 www.moog.com