

EXCALIBUR SERIES

MIL-DTL-38999 OPTICAL TRANSPONDER, XAUI TO 10GBASE-SR APPLICATIONS, MULTIMODE, 850 NM VCSEL'S



Excalibur series optical fiber transponders consist of optoelectronic transmitter and receiver functions integrated into a bulkhead mounted MIL-DTL-38999, series III receptacle connector along with the 10 Gbps / XAUI SerDes functions. The optical transmitters are 850 nM VCSEL lasers.

The optical receivers consist of PIN and preamplifier assemblies and limiting post-amplifiers. The XAUI electrical interface to the Excalibur series optical fiber transponders is a Samtec controlled impedance connector enabling interface to a ribbon twinax cable or flexible printed circuit assembly.

Excalibur series optical fiber transponders are vibration isolated, environmentally hardened components designed for use in harsh environment applications.

DUAL PORT EXCALIBUR SERIES MIL-DTL-38999 OPTICAL TRANSPONDER, 10GBASE-SR / XAUI APPLICATIONS, MULTIMODE, 850 NM VCSELS

Dual Port, Jam Nut
Dual Port XAUI to 10GBase-SR Transponder

FEATURES

- Suitable for 10GBASE-SR / SRL 10G Ethernet applications @ 10.3125 Gbps
- Optical fiber link distances up to 300 meters (50 / 125µ 2,000 MHz*Km MMF)
- Maximum optical channel bit error rate less than 1×10^{-12}
- Operating temperature range from -40° to +70° C
- Shock, vibration and immersion resistant per MIL-STD-810 and MIL-STD-1344
- Aluminum alloy MIL-DTL-38999 housings are strong, durable, corrosion resistant and light weight
- MIL-T-29504 compliant optical fiber connector interface
- Connector insert configuration conforms to MIL-STD-1560

APPLICATIONS

Excalibur series bulkhead mounted optical transponders enable extremely high speed network communications over long distances in harsh environments.

- 10 Gigabit Ethernet switches and peripherals
- 10 Gigabit Fibre Channel switches and peripherals
- Serial data links
- Video displays

The MIL-DTL-38999, series III shell provides a sealed optical interface that is water-tight to MIL-STD-810 / IP67 / NEMA-4x when mated.

The multimode optical fiber interface supports applications where copper cable link distance, bandwidth, weight or bulk make the use of twisted pair, twinax or quadrax copper conductors unacceptable.

ORDERING INFORMATION

Application	Part Number
XAUI to 10GBase-SR	E38J-4SCK-EF

See Appendix A2 for more part number options.

DUAL PORT EXCALIBUR SERIES MIL-DTL-38999 OPTICAL TRANSPONDER, 10GBASE-SR / XAUI APPLICATIONS, MULTIMODE, 850 NM VCSELS

ABSOLUTE MAXIMUM RATINGS

Absolute maximum limits mean that no catastrophic damage will occur if the product is subjected to these ratings for short periods, provided each limiting parameter is in isolation and all other parameters have values within the performance specification. It should not be assumed that limiting values of more than one parameter can be applied to the product at the same time.

Parameter	Symbol	Minimum	Typical	Maximum	Unit
Storage Temperature	T_s	-55		+100	°C
Supply Voltage	V_{CC}	-0.5		+6.0	V

RECOMMENDED OPERATING CONDITIONS

Parameter	Symbol	Minimum	Typical	Maximum	Unit
Operating Temperature	T_A	-40		+70	°C
Supply Voltage	V_{CC}	+4.75		+5.25	V
TX Common Mode Voltage	V_{CM}		2.0		V
TX Differential Input Voltage (p-p)	V_D	0.25		2.2	V
Power Supply Noise (p-p)	N_p			200	mV

INTERFACE SPECIFICATIONS COMPLIANCE

Requirement	Feature	Condition	Notes
MIL-STD-883	ESD	Class II	2200 V
MIL-STD-810	Vibration	3.8 g ² / Hz	43 G rms
MIL-STD-810	Shock	40.0 g	6-9 mS
MIL-STD-810	Immersion	1.0 Meter	2.0 Hours
MIL-STD-1344	Flame Resistance	Method 1012	30 Seconds
MIL-STD-1344	Damp Heat	10 Cycles	24 Hours
MIL-STD-38999	Mating Durability	500 Cycles	< 0.5 dB Change
FDA / CDRH / IEC-825-1	Eye Safety	Class 1	No Safety Interlocks Required

MATERIALS

Item	Detail	Notes
Housing and Shell	Aluminum Alloy	
Housing and Shell Plating	Electroless Nickel	
Insert	Thermoplastic	
Interfacial Seal	Elastomer	
Optical Ferrules	Ceramic	
Printed Circuits	Polyimide / FR-4	

DUAL PORT EXCALIBUR SERIES MIL-DTL-38999 OPTICAL TRANSPONDER, 10GBASE-SR / XAUI APPLICATIONS, MULTIMODE, 850 NM VCSELS

OPTICAL TRANSMITTERS T_A = OPERATING TEMPERATURE RANGE, V_{CC} = 4.75 V TO 5.25 V

Parameter	Symbol	Minimum	Typical	Maximum	Unit
Optical Output Power (BER < 10 ⁻¹²)	P_O	-5.0		-1.0	dBm
Optical Output Wavelength	λ_{OUT}	840	850	860	nM
Spectral Width	$\Delta\lambda_{RMS}$			0.45	nM
Extinction Ratio	ER	3.0	5.5		dB

OPTICAL RECEIVERS T_A = OPERATING TEMPERATURE RANGE, V_{CC} = 4.75 V TO 5.25 V

Parameter	Symbol	Minimum	Typical	Maximum	Unit
Optical Sensitivity (BER < 10 ⁻¹²)	P_I	-11.1		0.0	dBm
Optical Wavelength	λ_{IN}	840		860	nM

ELECTRICAL AC CHARACTERISTICS T_A = OPERATING TEMPERATURE RANGE, V_{CC} = 4.75 V TO 5.25 V

Parameter	Symbol	Minimum	Typical	Maximum	Unit
XAUI Input / Output Baud Rate - TXLANE[0..3] and RXLANE[0..3]	$R_{XAUI IN / OUT}$		3.125		Gbit/s
Baud Rate Variation	$R_{XAUI IN / OUT}$	-100		100	ppm
Differential Input / Output Impedance	$Z_{XAUI IN / OUT}$	80	100	120	Ω
Input Differential Skew	$t_{SKEW IN}$			75	ps
Output Differential Skew	$t_{SKEW OUT}$			15	ps

POWER SUPPLY CURRENT T_A = OPERATING TEMPERATURE RANGE, V_{CC} = 4.75 V TO 5.25 V

Parameter	Symbol	Minimum	Typical	Maximum	Unit
Supply Current Per Port	I_{OCT}		380	450	mA

OPTICAL LINK DISTANCES

Cable Type	62.5 / 125 μ 160 MHz*Km	62.5 / 125 μ 200 MHz*Km	50 / 125 μ 400 MHz*Km	50 / 125 μ 500 MHz*Km	50 / 125 μ 2000 MHz*Km
Maximum Supported Link Distance - Meters	26	33	66	82	300

DUAL PORT EXCALIBUR SERIES MIL-DTL-38999 OPTICAL TRANSPONDER, 10GBASE-SR / XAUI APPLICATIONS, MULTIMODE, 850 NM VCSELS

OUTLINE DRAWING - JAM NUT OPTION

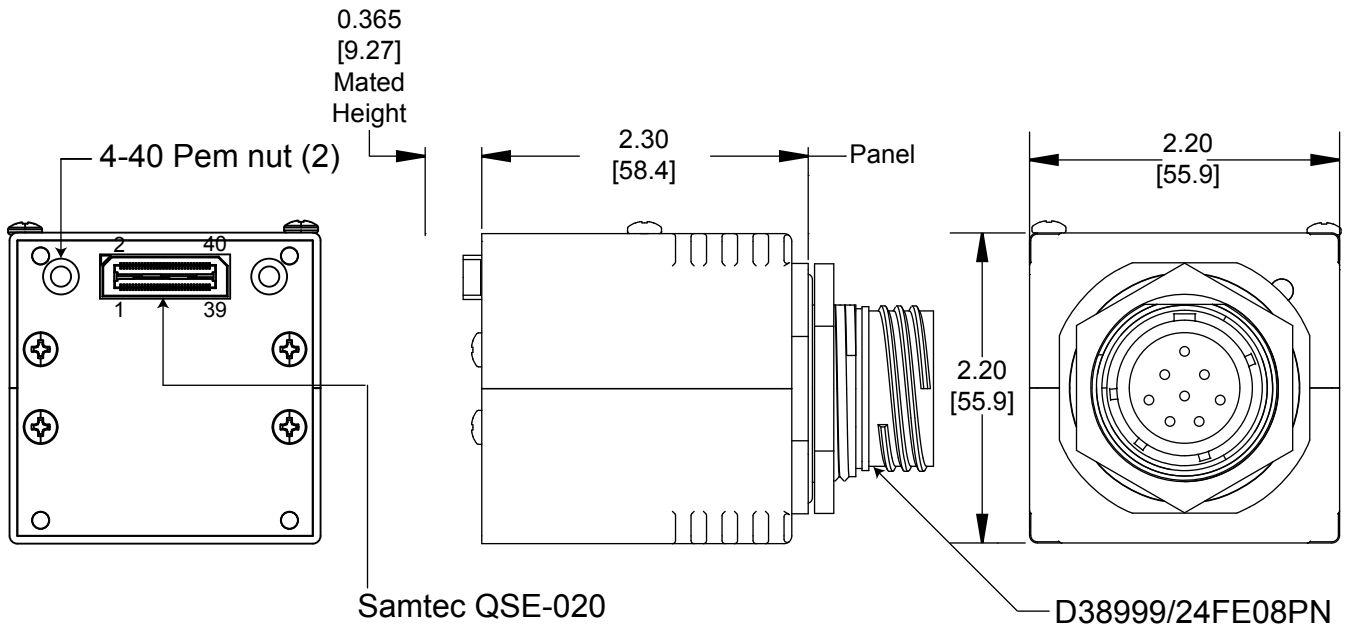

Dimensions are shown as: inches [mm]

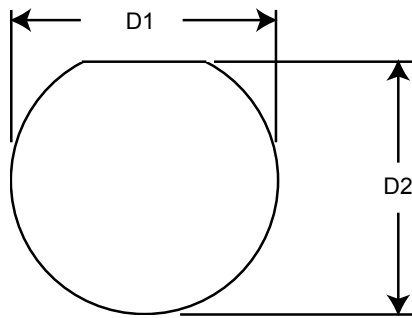

PANEL CUTOUT DIMENSIONS

Shell Size Code	Shell Size	D1 Min.	D2 Min.
E	17	1.260 (32.01)	1.210 (30.73)

DUAL PORT EXCALIBUR SERIES MIL-DTL-38999 OPTICAL TRANSPONDER, 10GBASE-SR / XAUI APPLICATIONS, MULTIMODE, 850 NM VCSELS

OPTICAL TRANSCEIVER INSERT ARRANGEMENT

TOP
Optical Interface

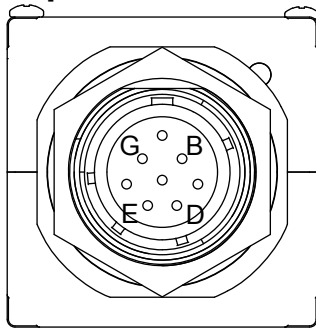

Front face of the optical transponder insert shown, fiber optic cable plug opposite - see Appendix A1 for details.

TOP
Electrical Interface

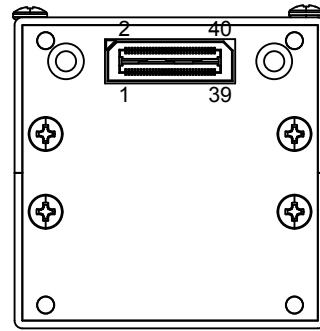

Back face of the optical transponder insert shown, see Electrical Pin Assignment pages for details.

OPTICAL TRANSPONDER PORT ASSIGNMENTS

Port Number	TX	RX
0	G	E
1	B	D

DUAL PORT EXCALIBUR SERIES MIL-DTL-38999 OPTICAL TRANSPONDER, 10GBASE-SR / XAUI APPLICATIONS, MULTIMODE, 850 NM VCSELS

ELECTRICAL PIN ASSIGNMENTS

Pin	Symbol	Port	Lane	I/O	+/-	Description	Logic Family
1	XAUI(0)_IN(0)_P	0	0	I	+	XAUI TX Lane 0 +	AC-Coupled, Internally Biased Differential XAUI
2	XAUI(0)_OUT(0)_P	0	0	O	+	XAUI TX Lane 0 +	AC-Coupled, Internally Biased Differential XAUI
3	XAUI(0)_IN(0)_N	0	0	I	-	XAUI TX Lane 0 -	AC-Coupled, Internally Biased Differential XAUI
4	XAUI(0)_OUT(0)_N	0	0	O	-	XAUI TX Lane 0 -	AC-Coupled, Internally Biased Differential XAUI
5	XAUI(0)_IN(1)_P	0	1	I	+	XAUI TX Lane 1 +	AC-Coupled, Internally Biased Differential XAUI
6	XAUI(0)_OUT(1)_P	0	1	O	+	XAUI TX Lane 1 +	AC-Coupled, Internally Biased Differential XAUI
7	XAUI(0)_IN(1)_N	0	1	I	-	XAUI TX Lane 1 -	AC-Coupled, Internally Biased Differential XAUI
8	XAUI(0)_OUT(1)_N	0	1	O	-	XAUI TX Lane 1 -	AC-Coupled, Internally Biased Differential XAUI
9	XAUI(0)_IN(2)_P	0	2	I	+	XAUI TX Lane 2 +	AC-Coupled, Internally Biased Differential XAUI
10	XAUI(0)_OUT(2)_P	0	2	O	+	XAUI TX Lane 2 +	AC-Coupled, Internally Biased Differential XAUI
11	XAUI(0)_IN(2)_N	0	2	I	-	XAUI TX Lane 2 -	AC-Coupled, Internally Biased Differential XAUI
12	XAUI(0)_OUT(2)_N	0	2	O	-	XAUI TX Lane 2 -	AC-Coupled, Internally Biased Differential XAUI
13	XAUI(0)_IN(3)_P	0	3	I	+	XAUI TX Lane 3 +	AC-Coupled, Internally Biased Differential XAUI
14	XAUI(0)_OUT(3)_P	0	3	O	+	XAUI TX Lane 3 +	AC-Coupled, Internally Biased Differential XAUI
15	XAUI(0)_IN(3)_N	0	3	I	-	XAUI TX Lane 3 -	AC-Coupled, Internally Biased Differential XAUI
16	XAUI(0)_OUT(3)_N	0	3	O	-	XAUI TX Lane 3 -	AC-Coupled, Internally Biased Differential XAUI
17	GND	N/A	N/A	N/A	N/A	Isolated Signal Ground	N/A
18	VPX_5VDC	N/A	N/A	I	+	+4.75 to +5.25 VDC	N/A
19	GND	N/A	N/A	N/A	N/A	Isolated Signal Ground	N/A
20	VPX_5 VDC	N/A	N/A	I	+	+4.75 to +5.25 VDC	N/A
21	GND	N/A	N/A	N/A	N/A	Vendor Use Only, Tie to GND	N/A
22	TX_DIS	0	N/A	I	+	TX_Dis Port 0	*Open Drain CMOS, 3.3 VDC = TX_OFF / Low=TX_ON
23	GND	N/A	N/A	N/A	N/A	Vendor Use Only, Tie to GND	N/A
24	TX_DIS	1	N/A	I	+	TX_Dis Port 1	*Open Drain CMOS, 3.3 VDC = TX_OFF / Low=TX_ON
25	XAUI(0)_IN(0)_P	1	0	I	+	XAUI TX Lane 0 +	AC-Coupled, Internally Biased Differential XAUI
26	XAUI(0)_OUT(0)_P	1	0	O	+	XAUI RX Lane 0 +	AC-Coupled, Internally Biased Differential XAUI
27	XAUI(0)_IN(0)_N	1	0	I	-	XAUI TX Lane 0 -	AC-Coupled, Internally Biased Differential XAUI
28	XAUI(0)_OUT(0)_N	1	0	O	-	XAUI TX Lane 0 -	AC-Coupled, Internally Biased Differential XAUI
29	XAUI(0)_IN(1)_P	1	1	I	+	XAUI TX Lane 1 +	AC-Coupled, Internally Biased Differential XAUI
30	XAUI(0)_OUT(1)_P	1	1	O	+	XAUI TX Lane 1 +	AC-Coupled, Internally Biased Differential XAUI
31	XAUI(0)_IN(1)_N	1	1	I	-	XAUI TX Lane 1 -	AC-Coupled, Internally Biased Differential XAUI
32	XAUI(0)_OUT(1)_N	1	1	O	-	XAUI TX Lane 1 -	AC-Coupled, Internally Biased Differential XAUI
33	XAUI(0)_IN(2)_P	1	2	I	+	XAUI TX Lane 2 +	AC-Coupled, Internally Biased Differential XAUI
34	XAUI(0)_OUT(2)_P	1	2	O	+	XAUI TX Lane 2 +	AC-Coupled, Internally Biased Differential XAUI
35	XAUI(0)_IN(2)_N	1	2	I	-	XAUI TX Lane 2 -	AC-Coupled, Internally Biased Differential XAUI
36	XAUI(0)_OUT(2)_N	1	2	O	-	XAUI TX Lane 2 -	AC-Coupled, Internally Biased Differential XAUI
37	XAUI(0)_IN(3)_P	1	3	I	+	XAUI TX Lane 3 +	AC-Coupled, Internally Biased Differential XAUI
38	XAUI(0)_OUT(3)_P	1	3	O	+	XAUI TX Lane 3 +	AC-Coupled, Internally Biased Differential XAUI
39	XAUI(0)_IN(3)_N	1	3	I	-	XAUI TX Lane 3 -	AC-Coupled, Internally Biased Differential XAUI
40	XAUI(0)_OUT(3)_N	1	3	O	-	XAUI TX Lane 3 -	AC-Coupled, Internally Biased Differential XAUI

*Note: Internal pullup is factory default

DUAL PORT EXCALIBUR SERIES MIL-DTL-38999 OPTICAL TRANSPONDER, 10GBASE-SR / XAUI APPLICATIONS, MULTIMODE, 850 NM VCSELS

APPENDIX A1 MIL-DTL-38999 FIBER OPTIC CABLE PLUG / MIL-T-29504 RECEPTACLE TERMINI

*See DSCC or SAE QPL for Approved Suppliers
<http://www.dsccl.dla.mil/programs/qmlqpl/QPLdetail.asp?QPL=38999>

*D38999 PLUG - RECEPTACLE INSERT MIL-DTL-38999 CABLE PLUG

MS Plug P/N *D38999 / 26WE085N

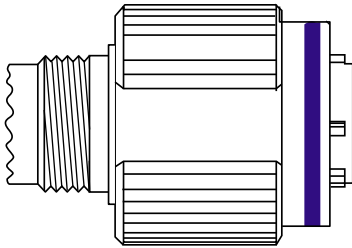

*CABLE PROTECTION CAP D38999 / 32 PLUG PROTECTION CAP

MS Plug Cap P/N *D38999 / 32W17N

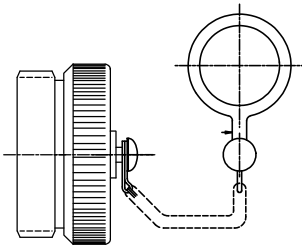

*CABLE BACKSHELL MIL-C-85049 CABLE BACKSHELL

MS Backshell P/N *MS85049 / XXXXXX**

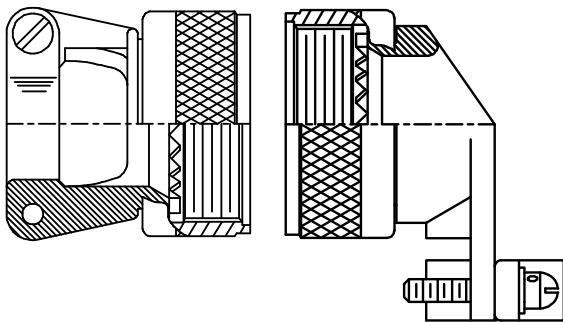

**Straight or angled backshell - defined by application / mounting configuration

*FIBER OPTIC TERMINUS M29504 RECEPTACLE TERMINUS

Receptacle *M29504 / 05-xxxx**



**Defined by fiber optic cable configuration

D38999 PLUG PORT FUNCTIONS

Port Number	TX	RX
0	G	E
1	B	D

DUAL PORT EXCALIBUR SERIES MIL-DTL-38999 OPTICAL TRANSPONDER, 10GBASE-SR / XAUI APPLICATIONS, MULTIMODE, 850 NM VCSELS

APPENDIX A2 PART NUMBER OPTIONS

SINGLE PORT, SQUARE FLANGE, VCSEL

E38 J - 4 S C K - E x x

PRODUCT CONFIGURATION

E38 = Excalibur Series

SHELL CONFIGURATION

J = Jam Nut

CHANNELS (TX + RX)

4 = 2 TX + 2 RX

WAVELENGTH

S = 850 nM

POWER SUPPLY

C = +5 VDC

FIBER OPTIC INTERFACE

K = 10 Gbps

SHELL SIZE CODE

E = 17-08

SHELL PLATING

F = NI

W = OD CD / NI

Z = ZN / NI

POLARIZATION

(Leave blank) = N

A = A

B = B

C = C

D = D

Other wavelength, mounting and port count options are available.

Please consult the Protokraft website for alternate configurations.



192 Bob Fitz Road, Johnson City, TN 37615

salesmp@moog.com

www.moog.com