

## MUSTANG SERIES

FAST ETHERNET, TFOCA II®, 100BASE-TX / FX MEDIA CONVERTER, MULTIMODE, 1310 NM

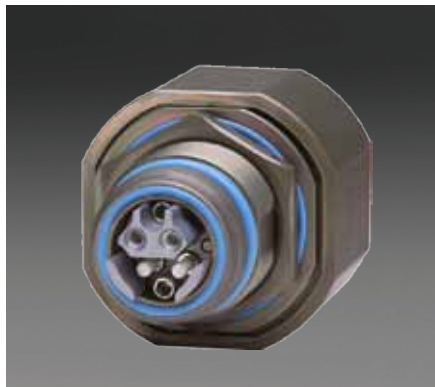

Mustang series Fast Ethernet media converters consist of optoelectronic transmitter and receiver functions integrated along with the 100Base-TX electrical to 100Base-FX optical media conversion circuitry into a jam-nut TFOCA II® fiber optic connector assembly.

The optical transmitters are high output 1310 nM devices. The optical receivers consist of InGaAs PIN and preamplifier assemblies and limiting post-amplifiers.

The electrical interface to the Mustang series optical media converters is a MIL-DTL-83513 Micro D-Subminiature pin connector enabling interconnection to a customer supplied flexible circuit or cable assembly.

Mustang series Fast Ethernet media converters are vibration isolated, environmentally hardened components designed for use in harsh environment applications.

- Sealed against liquid and solid contaminants
- Shock and vibration resistant

# DUAL PORT \*TFOCA II® CONNECTOR, 100BASE-TX TO 100BASE-FX MEDIA CONVERTER, MULTIMODE, 1310 NM

Dual Port, Jam Nut  
TFOCA II® to M83513 / Optical to Electrical Media Converter

## FEATURES

- Compliant with IEEE-802.3:2005 Fast Ethernet 100Base-TX and 100Base-FX
- Optical fiber link distances up to 2.0 kilometers
- Copper link distances up to 100 meters (EIA / TIA Cat-5E)
- Operating temperature range from -40° to +85° C
- Shock, vibration and immersion resistant per MIL-STD-810
- Zinc nickel plating meets stringent EMI / RFI and corrosion resistance performance specifications
- Aluminum housings are strong, durable and light weight
- TFOCA II® compliant optical fiber connector interface
- MIL-DTL-83513 electrical interface with #2 - 56 jacksockets

## APPLICATIONS

Mustang series bulkhead mounted Fast Ethernet media converters enable high speed network communications over long distances in harsh environments.

- Fast Ethernet switches and peripherals
- Telecom and datacom switch / router rack-to-rack links
- Storage or computation clusters

The TFOCA II® shell provides a sealed optical interface that is water-tight to MIL-STD-810 when mated.

The multimode optical fiber interface supports applications where copper cable link distance, bandwidth, weight or bulk make the use of twisted pair, twinax or quadrx copper conductors unacceptable.

*\*TFOCA-II® is a registered trademark of Amphenol Fiber Systems International*

### ORDERING INFORMATION

Application	Part Number
Dual Port 100Base-TX / FX - 28 VDC	P51J-4LAU-FZ-M

For additional product options see Appendix A2.

# DUAL PORT \*TFOCA II® CONNECTOR, 100BASE-TX TO 100BASE-FX MEDIA CONVERTER, MULTIMODE, 1310 NM

## ABSOLUTE MAXIMUM RATINGS

Absolute maximum limits mean that no catastrophic damage will occur if the product is subjected to these ratings for short periods, provided each limiting parameter is in isolation and all other parameters have values within the performance specification. It should not be assumed that limiting values of more than one parameter can be applied to the product at the same time.

Parameter	Symbol	Minimum	Typical	Maximum	Unit
Storage Temperature	T <sub>S</sub>	-55		+100	°C
Supply Voltage	V <sub>CC</sub>	-0.5		45.0	V
Data Input Voltage	V <sub>I</sub>	-0.5		V <sub>CC</sub>	V

## RECOMMENDED OPERATING CONDITIONS

Parameter	Symbol	Minimum	Typical	Maximum	Unit
Operating Temperature	T <sub>A</sub>	-40		+85	°C
Supply Voltage	V <sub>CC</sub>	+18.0	+28.0	+36.0	VDC
Power Supply Noise (p-p)	N <sub>P</sub>			200	mV

## INTERFACE SPECIFICATIONS COMPLIANCE

Requirement	Feature	Condition	Notes
MIL-STD-883	ESD	Class II	2200 V
MIL-STD-810	Vibration	3.8 g <sup>2</sup> / Hz	43 G rms
MIL-STD-810	Shock	40.0 g	6-9 mS
MIL-STD-1344	Flame Resistance	Method 1012	30 Seconds
MIL-STD-1344	Damp Heat	10 Cycles	24 Hours
TFOCA II	Mating Durability	2000 Cycles	EIA / TIA-455-21
FDA / CDRH / IEC-825-1	Eye Safety	Class 1	No Safety Interlocks Required

## MATERIALS

Item	Detail	Notes
Shells	Aluminum	
Shell Plating	Zinc Nickel / Nickel	
Insert	Thermoplastic	
Interfacial Seal	Elastomer	
Alignment Sleeves	Zirconia	
Printed Circuits	Polyimide / FR-4	MIL-P-31032 Type 4
Housing	Aluminum	

# DUAL PORT \*TFOCA II® CONNECTOR, 100BASE-TX TO 100BASE-FX MEDIA CONVERTER, MULTIMODE, 1310 NM

## TRANSMITTERS $T_A$ = OPERATING TEMPERATURE RANGE

Parameter	Symbol	Minimum	Typical	Maximum	Unit
Optical Output Power	$P_o$	-15.0		-3.0	dBm
Optical Output Wavelength	$\lambda_{OUT}$	1260	1380	860	nM

## RECEIVERS $T_A$ = OPERATING TEMPERATURE RANGE

Parameter	Symbol	Minimum	Typical	Maximum	Unit
Optical Sensitivity	$P_i$	-31.5		-6.0	dBm
Optical Wavelength	$\lambda_{IN}$	1100		1590	nM

## SUPPLY CURRENT $T_A$ = OPERATING TEMPERATURE RANGE

Parameter	Symbol	Minimum	Typical	Maximum	Unit
Supply Current per Port	$I_{CCT}$		100	150	mA

## OPTICAL FIBER LINK DISTANCES

Application	Fiber Specification	Distance
Fast Ethernet - IEEE 802.3u FDDI PMD ISO / IEC 9314-3	62.5 / 125 $\mu$ - 500 MMF	2.0 Km
	50 / 125 $\mu$ - 500 MMF	2.0 Km

# DUAL PORT \*TFOCA II® CONNECTOR, 100BASE-TX TO 100BASE-FX MEDIA CONVERTER, MULTIMODE, 1310 NM

## OUTLINE DRAWING

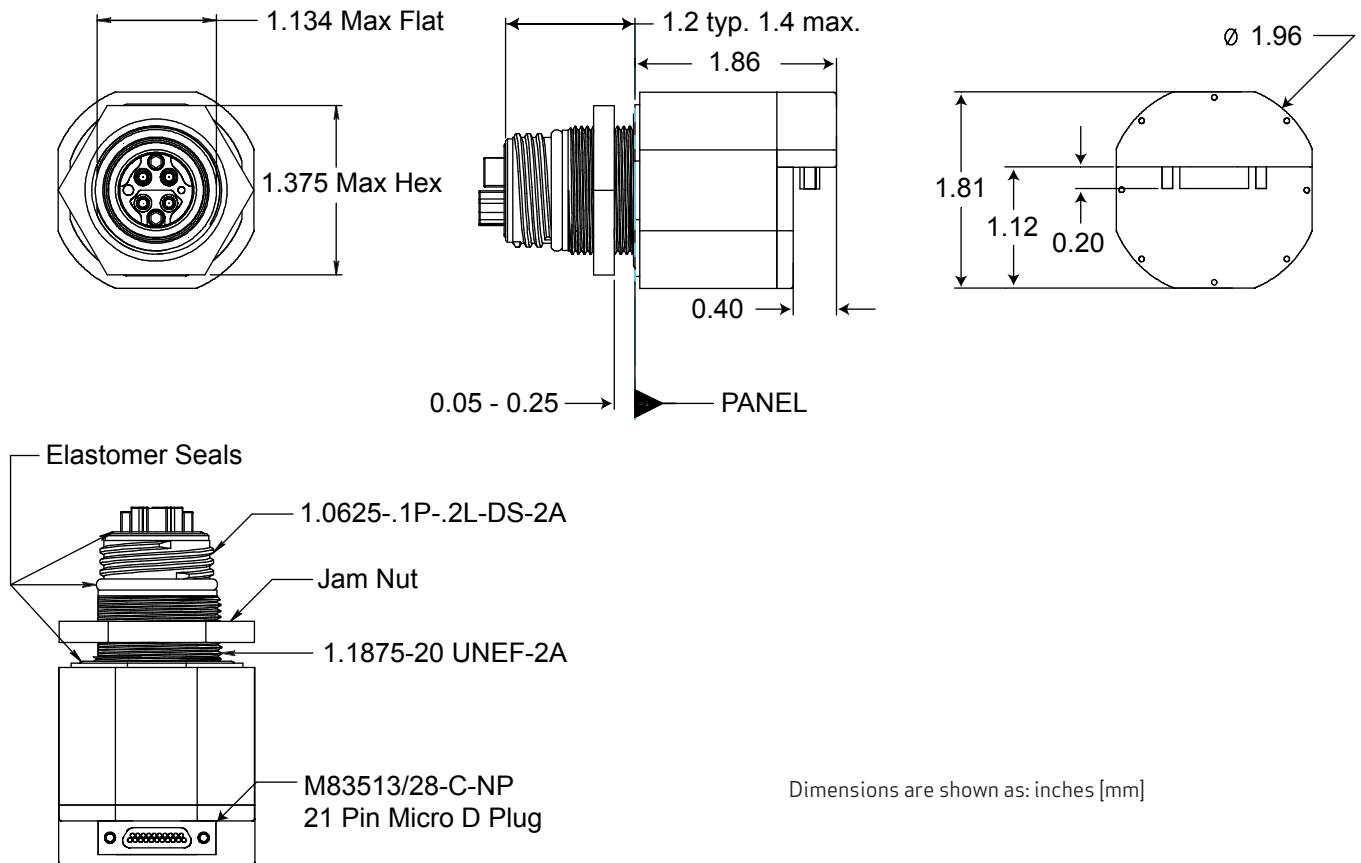

## PANEL CUTOUT DIMENSIONS

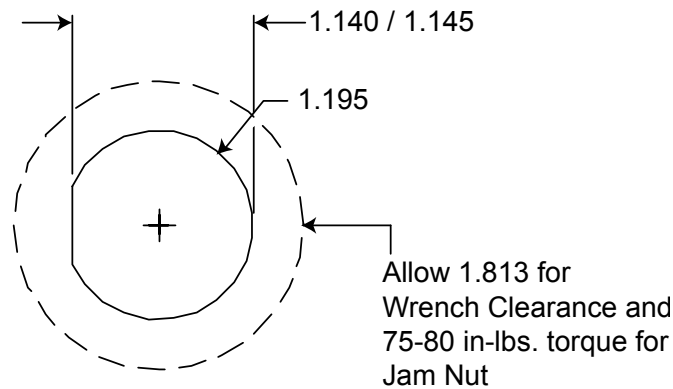

Dimensions are shown as: inches [mm]

# DUAL PORT \*TFOCA II® CONNECTOR, 100BASE-TX TO 100BASE-FX MEDIA CONVERTER, MULTIMODE, 1310 NM

## MEDIA CONVERTER OPTICAL INSERT AND ELECTRICAL PIN ARRANGEMENT

TOP  
Optical Interface

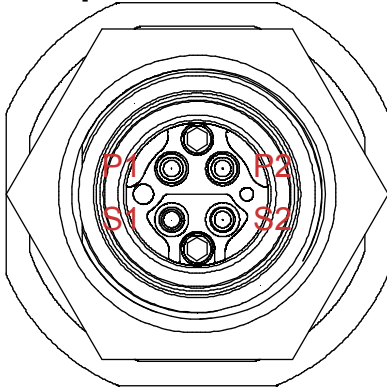

Front view of the TFOCA II media converter optical insert shown - fiber optic cable plug opposite - see Appendix A1 for details.

### OPTICAL PORT ASSIGNMENTS TFOCA II OPTICAL INTERFACE

Port Number	RX	TX
0	P2	S2
1	P1	S1

TOP  
Electrical Interface

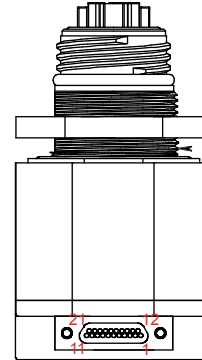

Back view of the media converter shown - see Electrical Pin Function Chart for more details.

### ELECTRICAL PIN ASSIGNMENTS MICRO-D ELECTRICAL INTERFACE

Pin Number	Port Number	Function	Pin Number	Port Number	Function
1	0	TX_D1+	12	1	TX_D1+
2	0	TX_D1-	13	1	TX_D1-
3	0	RX_D2+	14	1	RX_D2+
4	0	RX_D2-	15	1	RX_D2-

# DUAL PORT \*TFOCA II® CONNECTOR, 100BASE-TX TO 100BASE-FX MEDIA CONVERTER, MULTIMODE, 1310 NM

## SAMTEC EQCD PIN ASSIGNMENTS

Pin Number	Port Number	Function	Input / Output	Logic Family
1	0	TX_D1+	Input / Output	IEEE-802.3:2005 100Base-T
2	0	TX_D1-	Input / Output	IEEE-802.3:2005 100Base-T
3	0	RX_D2+	Input / Output	IEEE-802.3:2005 100Base-T
4	0	RX_D2-	Input / Output	IEEE-802.3:2005 100Base-T
5	N/A	NC	N/A	N/A
6	N/A	NC	N/A	N/A
7	N/A	NC	N/A	N/A
8	N/A	NC	N/A	N/A
9	N/A	NC	N/A	N/A
10	N/A	NC	N/A	N/A
11	N/A	NC	N/A	N/A
12	1	TX_D1+	Input	IEEE-802.3:2005 100Base-T
13	1	TX_D1-	Input	IEEE-802.3:2005 100Base-T
14	1	RX_D2+	Output	IEEE-802.3:2005 100Base-T
15	1	RX_D2-	Output	IEEE-802.3:2005 100Base-T
16	N/A	NC	N/A	N/A
17	N/A	NC	N/A	N/A
18	N/A	NC	N/A	N/A
19	N/A	NC	N/A	Do Not Connect - Factory Use Only
20	0 / 1	GND	N/A	N/A
21	0 / 1	V <sub>CC</sub>	Input	N/A

# DUAL PORT \*TFOCA II® CONNECTOR, 100BASE-TX TO 100BASE-FX MEDIA CONVERTER, MULTIMODE, 1310 NM

## APPLICATION SCHEMATIC

For Dual Port 10/100Base-TX to 100Base-FX Media Converter Applications

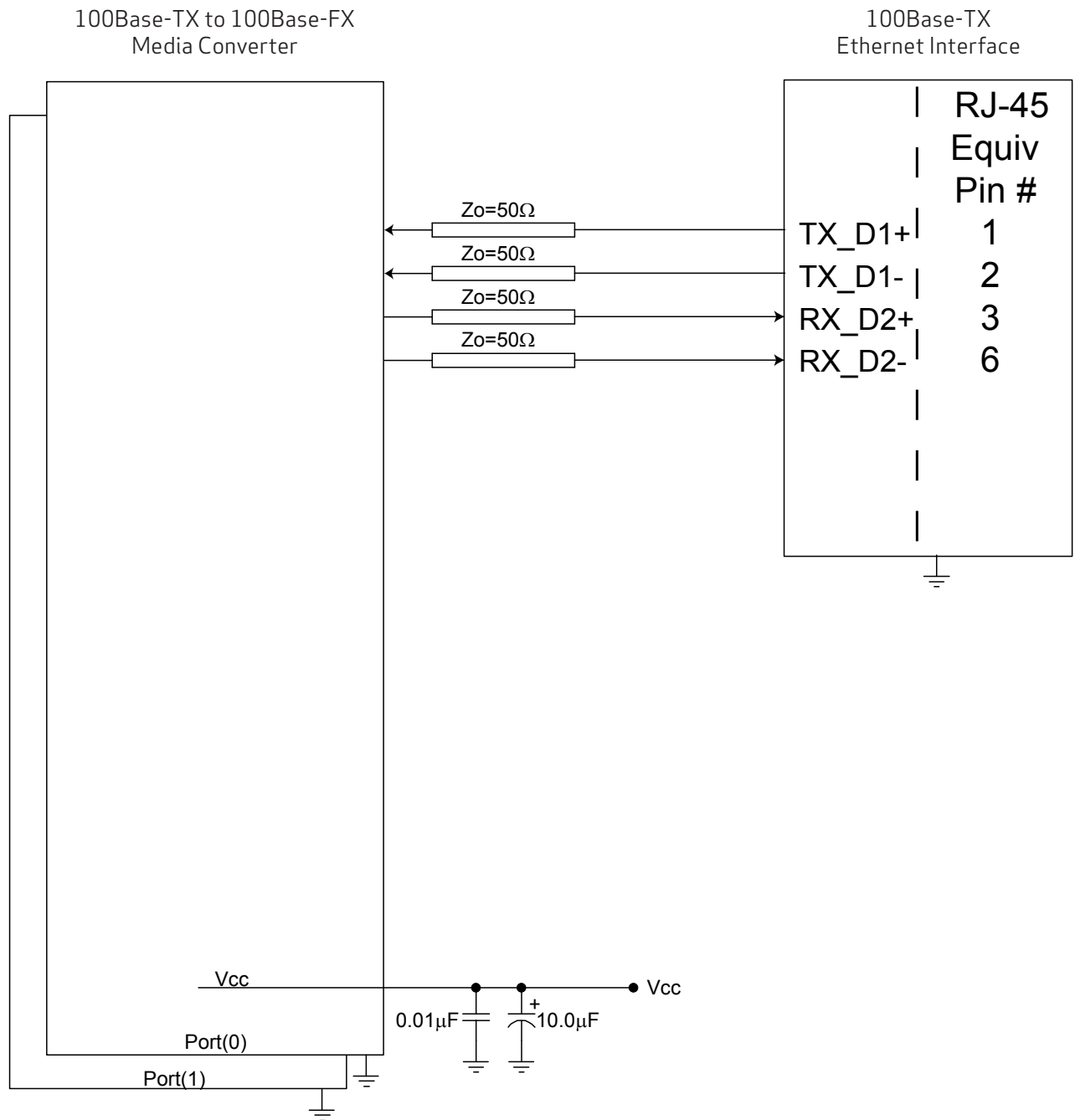

All Protokraft statements, technical information and recommendations related to the products herein are based upon information believed to be reliable or accurate. However, the accuracy or completeness thereof is not guaranteed, and Protokraft assumes no responsibility for any inaccuracies. The user assumes all risks and liability whatsoever in connection with the use of a product or its application. Protokraft reserves the right to change at any time, without prior or subsequent notice, the design, specifications, function, fit or form of its products described herein, including withdrawal at any time of a product offered for sale herein. Protokraft makes no representations that the products herein are free from any intellectual property claims of others. Protokraft and the Protokraft logo are trademarks of Protokraft, LLC. Other trademarks are the property of their respective holders. Contact Protokraft for prices and availability. For the most recent version of this data sheet, please go to the Protokraft website at <http://www.protokraft.com>. In case of discrepancy, the web version takes precedence over any printed literature. ©2004 Protokraft, LLC. All rights reserved.

# DUAL PORT \*TFOCA II® CONNECTOR, 100BASE-TX TO 100BASE-FX MEDIA CONVERTER, MULTIMODE, 1310 NM

## APPENDIX A1 - TFOCA-II® 4 CHANNEL FIBER OPTIC CABLE PLUG

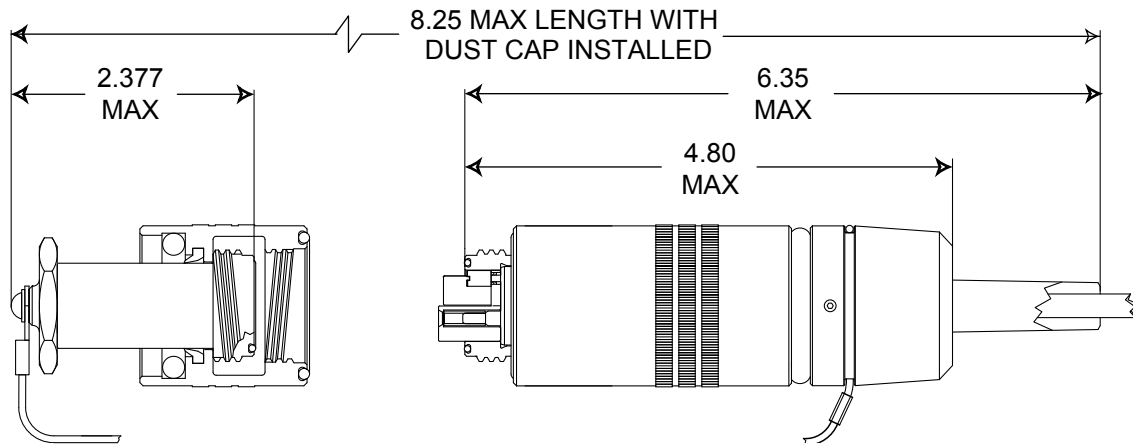

**Amphenol Fiber Systems International®**  
**TFOCA-II® 4-Channel Connector Part Numbers\***

\*Contact Amphenol Fiber Systems International for more information

## TFOCA II® RECEPTACLE PROTECTION CAPS

RECEPTACLE CAP P/N CONTACT AMPHENOL FIBER SYSTEMS INTERNATIONAL

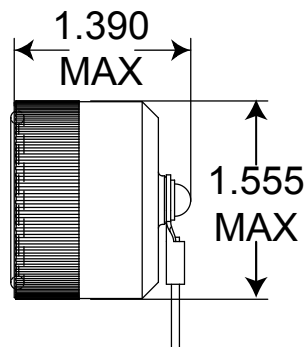

# DUAL PORT \*TFOCA II® CONNECTOR, 100BASE-TX TO 100BASE-FX MEDIA CONVERTER, MULTIMODE, 1310 NM

## APPENDIX A2 - CABLE ASSEMBLY CONSTRUCTION OPTIONS

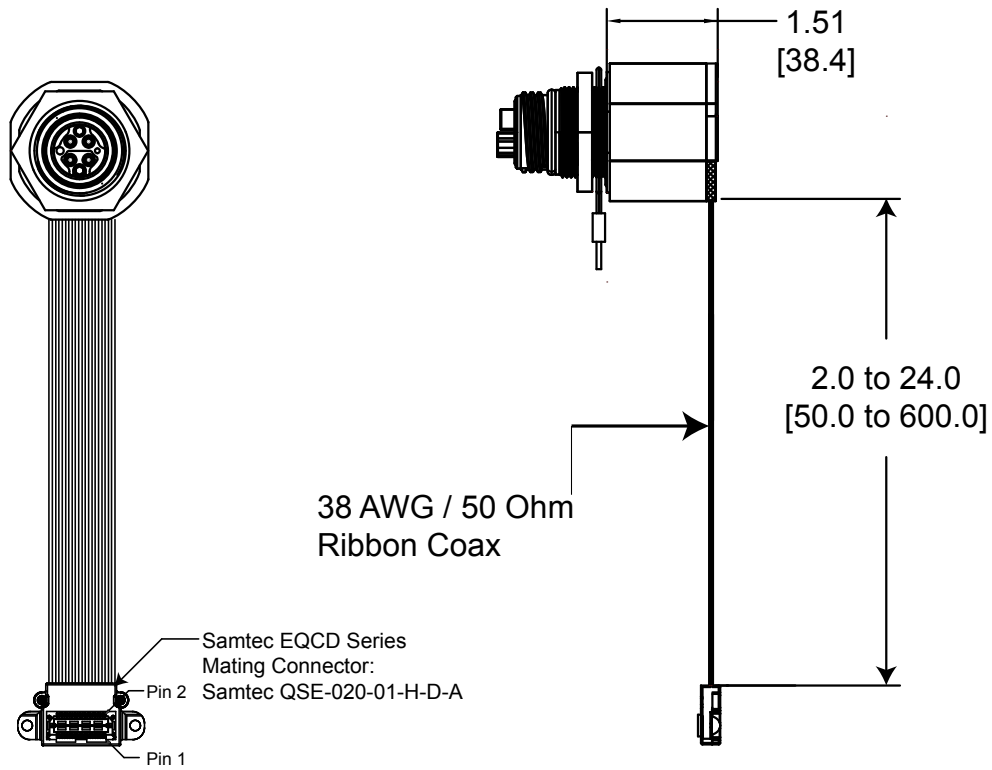

Dimensions are shown as: inches [mm]

**Part Numbers = P51J-xxxx-xx-Lxxx\***  
\*See page 11 for standard length options.

# DUAL PORT \*TFOCA II® CONNECTOR, 100BASE-TX TO 100BASE-FX MEDIA CONVERTER, MULTIMODE, 1310 NM

## OUTLINE DRAWING - CABLE LENGTH OPTIONS

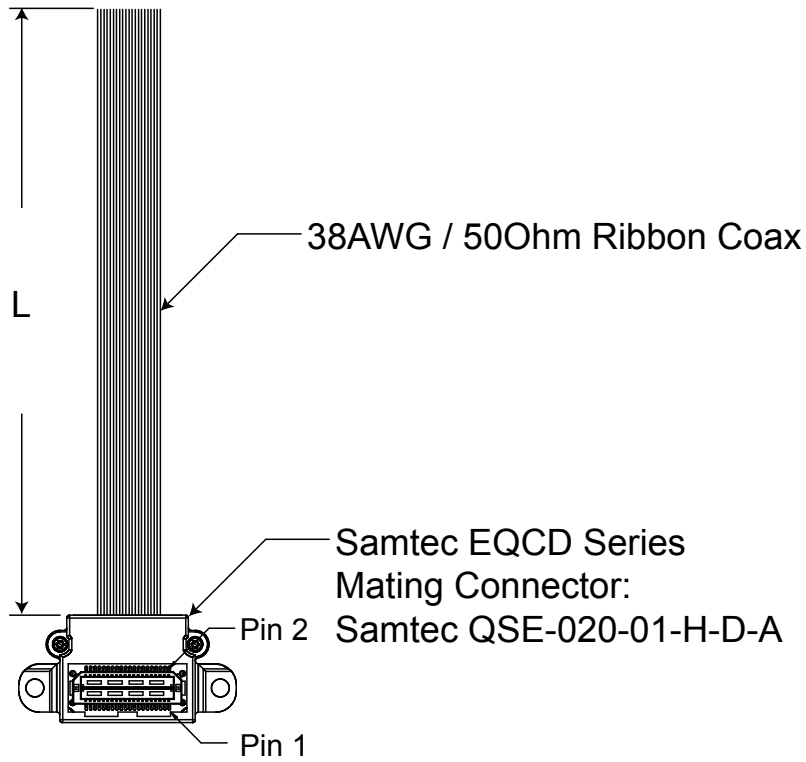

### RIBBON COAX CABLE LENGTH OPTIONS

L (mm) +/- 6.0	ITEM #
50	xxx-xxx-xx-L050
100	xxx-xxx-xx-L100
150	xxx-xxx-xx-L150
200	xxx-xxx-xx-L200
250	xxx-xxx-xx-L250

# DUAL PORT \*TFOCA II® CONNECTOR, 100BASE-TX TO 100BASE-FX MEDIA CONVERTER, MULTIMODE, 1310 NM

## PRINTED CIRCUIT BOARD FOOTPRINT

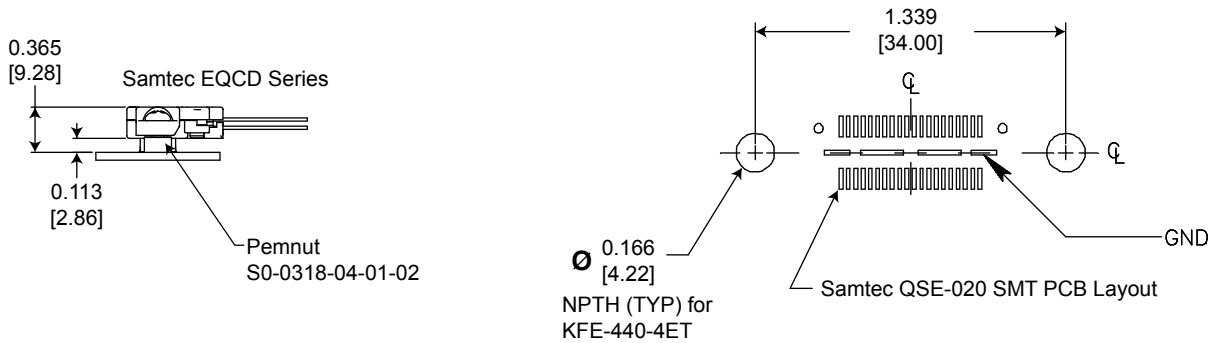

### SAMTEC EQCD PIN ASSIGNMENTS

Pin Number	Port Number	Function	Input / Output	Logic Family
1	0	TX_D1+	Output	IEEE-802.3:2005 100Base-TX
2	1	TX_D1+	Output	IEEE-802.3:2005 100Base-TX
3	0	TX_D1-	Output	IEEE-802.3:2005 100Base-TX
4	1	TX_D1-	Output	IEEE-802.3:2005 100Base-TX
5	0	RX_D2+	Input	IEEE-802.3:2005 100Base-TX
6	1	RX_D2+	Input	IEEE-802.3:2005 100Base-TX
7	0	RX_D2-	Input	IEEE-802.3:2005 100Base-TX
8	1	RX_D2-	Input	IEEE-802.3:2005 100Base-TX
19	0 - 1	V <sub>CC</sub>	Input	N/A
20	0 - 1	V <sub>CC</sub>	Input	N/A
21	0 - 1	V <sub>CC</sub>	Input	N/A
22	0 - 1	V <sub>CC</sub>	Input	N/A

\*Reset Function: Logic "0" Input = Restart, registers initialized; Logic "1", Open or High Z Input = Normal Operation, center slug is isolated GND, all other pins are N/C



192 Bob Fitz Road, Johnson City, TN 37615  
 salesmp@moog.com  
 moogprotokraft.com