

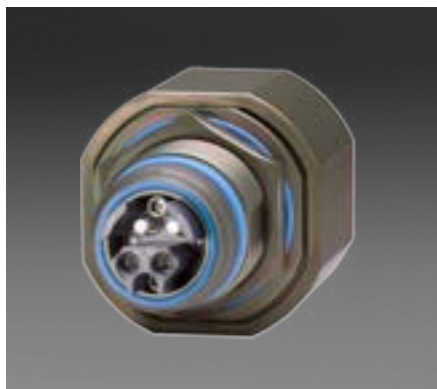

MUSTANG SERIES

GIGABIT ETHERNET, TFOCA II[®], 100BASE-T / FX AND 1000BASE-T / SX
MEDIA CONVERTER, MULTIMODE, 850 NM, 28 VDC



Mustang series Gigabit Ethernet media converters consist of optoelectronic transmitter and receiver functions integrated along with the 100/1000Base-TX electrical to 100Base-FX and 1000 Base-SX optical media conversion circuitry into a jam-nut TFOCA II[®] fiber optic connector assembly.

The optical transmitters are high output 850 nM devices. The optical receivers consist of GaAs PIN and preamplifier assemblies and limiting post-amplifiers.

The electrical interface to the Mustang series optical media converters is a MIL-DTL-38999 cylindrical connector enabling interconnection to a customer supplied cable assembly for 28 VDC power and Ethernet signal sources.

Mustang series Gigabit Ethernet media converters are vibration isolated, environmentally hardened components designed for use in harsh environment applications.

- Sealed against liquid and solid contaminants
- Shock and vibration resistant

DUAL PORT *TFOCA II® CONNECTOR, 100/1000BASE-T TO 100BASE-FX AND 1000BASE-SX MEDIA CONVERTER, MULTIMODE, 850 NM, 28 VDC

Dual Port, Jam Nut
TFOCA® II to D38999 / Optical to Electrical Media Converter

FEATURES

- Port 0 compliant with IEEE-802.3:2005 Fast Ethernet 100Base-T and 100Base-FX
- Port 1 Compliant with IEEE-802.3:2005 Gigabit Ethernet 1000Base-T and 1000Base-SX
- Optical fiber link distances up to 550 meters for GbE and 2.0 Km for Fast Ethernet
- Copper link distances up to 100 meters (EIA/TIA Cat-5E)
- Operating temperature range from -40° to +85° C
- Shock, vibration and immersion resistant per MIL-STD-810
- OD-CD plating meets stringent corrosion resistance specifications
- Aluminum housings are strong, durable and light weight
- TFOCA II® compliant optical fiber connector interface
- MIL-DTL-38999 electrical interface for power and signals

APPLICATIONS

Mustang series bulkhead mounted Gigabit Ethernet media converters enable high speed network communications over long distances in harsh environments.

- Fast and Gigabit Ethernet switches and peripherals
- Telecom and datacom switch / router rack-to-rack links
- Storage or computation clusters

The TFOCA II® shell provides a sealed optical interface that is water-tight to MIL-STD-810 when mated.

The multimode optical fiber interface supports applications where copper cable link distance, bandwidth, weight or bulk make the use of twisted pair, twinax or quadrx copper conductors unacceptable.

**TFOCA-II® is a registered trademark of Amphenol Fiber Systems International*

ORDERING INFORMATION

Application	Part Number
Dual Port 100Base-T / FX and 1000Base-T / SX	P51J-4SAS-FZ-V

DUAL PORT *TFOCA II® CONNECTOR, 100/1000BASE-T TO 100BASE-FX AND 1000BASE-SX MEDIA CONVERTER, MULTIMODE, 850 NM, 28 VDC

ABSOLUTE MAXIMUM RATINGS

Absolute maximum limits mean that no catastrophic damage will occur if the product is subjected to these ratings for short periods, provided each limiting parameter is in isolation and all other parameters have values within the performance specification. It should not be assumed that limiting values of more than one parameter can be applied to the product at the same time.

Parameter	Symbol	Minimum	Typical	Maximum	Unit
Storage Temperature	T _S	-55		+100	°C
Supply Voltage	V _{CC}	-0.5		45.0	V
Data Input Voltage	V _I	-0.5		V _{CC}	V

RECOMMENDED OPERATING CONDITIONS

Parameter	Symbol	Minimum	Typical	Maximum	Unit
Operating Temperature	T _A	-40		+85	°C
Supply Voltage	V _{CC}	+18.0	+28.0	+36.0	VDC
Power Supply Noise (p-p)	N _p			200	mV

INTERFACE SPECIFICATIONS COMPLIANCE

Requirement	Feature	Condition	Notes
MIL-STD-883	ESD	Class II	2200 V
MIL-STD-810	Vibration	3.8 g ² / Hz	43 G rms
MIL-STD-810	Shock	40.0 g	6-9 mS
MIL-STD-1344	Flame Resistance	Method 1012	30 Seconds
MIL-STD-1344	Damp Heat	10 Cycles	24 Hours
TFOCA II	Mating Durability	2000 Cycles	EIA / TIA-455-21
FDA / CDRH / IEC-825-1	Eye Safety	Class 1	No Safety Interlocks Required

MATERIALS

Item	Detail	Notes
D38999 and TFOCA II Cylindrical Shells	Aluminum	
D38999 and TFOCA II Finish	ZN-NI, OD-CD or NI	
D38999 Inserts	Thermoplastic	
Interfacial Seals	Elastomer	
Optical Ferrules	Zirconia	
Printed Circuits	FR-4	
Housing	Aluminum	

DUAL PORT *TFOCA II® CONNECTOR, 100/1000BASE-T TO 100BASE-FX AND 1000BASE-SX MEDIA CONVERTER, MULTIMODE, 850 NM, 28 VDC

TRANSMITTERS T_A = OPERATING TEMPERATURE, V_{CC} = OPERATING VOLTAGE RANGE

Parameter	Symbol	Minimum	Typical	Maximum	Unit
Optical Output Power	P_o	-9.5		-3.0	dBm
Optical Output Wavelength	λ_{OUT}	830	850	860	nM

RECEIVERS T_A = OPERATING TEMPERATURE RANGE, V_{CC} = OPERATING VOLTAGE RANGE

Parameter	Symbol	Minimum	Typical	Maximum	Unit
Optical Sensitivity	P_i	-19.0		0.0	dBm
Optical Wavelength	λ_{IN}	700		900	nM

SUPPLY CURRENT T_A = OPERATING TEMPERATURE RANGE, V_{CC} = OPERATING VOLTAGE RANGE

Parameter	Symbol	Minimum	Typical	Maximum	Unit
Supply Current per Port	I_{CCT}		150	200	mA

OPTICAL FIBER LINK DISTANCES

Application	Fiber Specification	Distance
Fast Ethernet - 100Base-FX	62.5 / 125 μ - 500 MMF	2.0 KM
	50 / 125 μ - 500 MMF	2.0 KM
Gigabit Ethernet - 1000Base-SX IEEE 802.3:2005	62.5 / 125 μ - 500 MMF	275 M
	50 / 125 μ - 500 MMF	550 M

DUAL PORT *TFOCA II® CONNECTOR, 100/1000BASE-T TO 100BASE-FX AND 1000BASE-SX MEDIA CONVERTER, MULTIMODE, 850 NM, 28 VDC

OUTLINE DRAWING

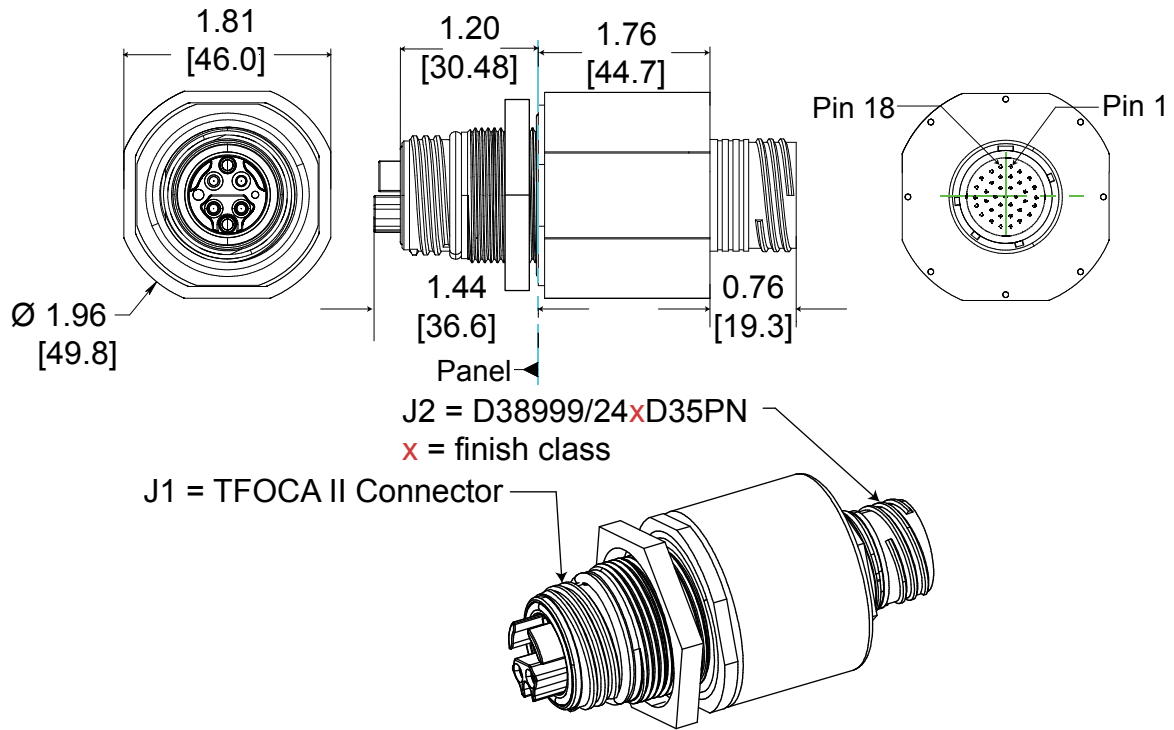

Dimensions are shown as: inches [mm]

PORT / FUNCTION ASSIGNMENTS

Port Number	Function
J1	1x100Base-FX and 1x1000Base-SX
J2	2x100/1000Base-T + 28 VDC

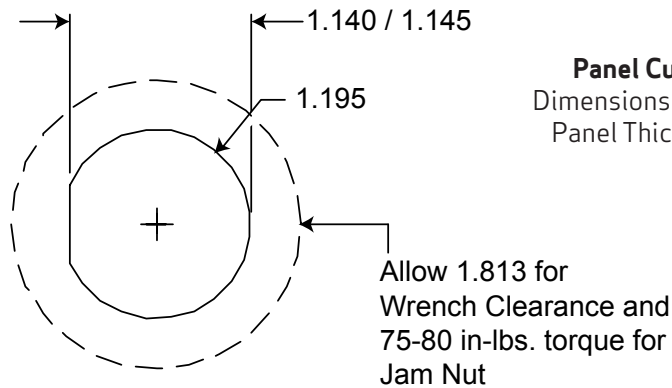

Panel Cutout Dimensions
 Dimensions are shown as: inches
 Panel Thickness: 0.12 to 0.26

DUAL PORT *TFOCA II® CONNECTOR, 100/1000BASE-T TO 100BASE-FX AND 1000BASE-SX MEDIA CONVERTER, MULTIMODE, 850 NM, 28 VDC

J1 OPTICAL INSERT PIN FUNCTIONS - ETHERNET PORT AND PIN ASSIGNMENTS

TOP

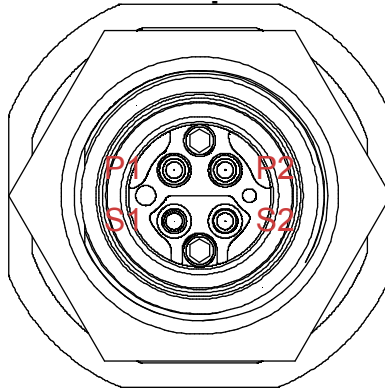

Front view of the TFOCA II media converter optical insert shown - fiber optic cable plug opposite

OPTICAL PIN / PORT ASSIGNMENTS		
Port Number	RX	TX
0	P2	S2
1	P1	S1

DUAL PORT *TFOCA II® CONNECTOR, 100/1000BASE-T TO 100BASE-FX AND 1000BASE-SX MEDIA CONVERTER, MULTIMODE, 850 NM, 28 VDC

J2 / D38999 / 24WD35PN ELECTRICAL PIN FUNCTIONS

TOP

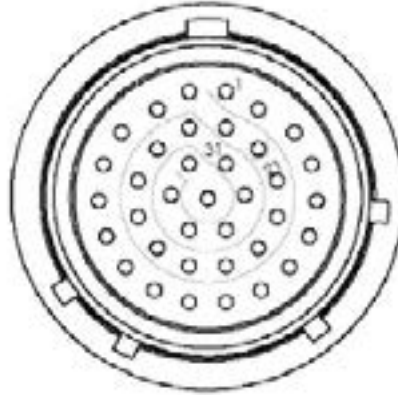

FRONT VIEW OF THE J2 CONNECTOR SHOWN - MATING CABLE PLUG OPPOSITE

Pin Number	Port	Function	RJ-45 Pin Number	Logic Family
1	0	NC	4	N/A
2	0	NC	5	N/A
3	0	NC	7	N/A
4	0	NC	8	N/A
5	0 - 1	28 VDC Rtn	N/A	N/A
6	1	MDD-	8	IEEE-802.3:2005 1000Base-T
7	1	MDD+	7	IEEE-802.3:2005 1000Base-T
8	1	MDC-	5	IEEE-802.3:2005 1000Base-T
9	1	MDC+	4	IEEE-802.3:2005 1000Base-T
10	1	MDB-	6	IEEE-802.3:2005 1000Base-T
11	1	MDB+	3	IEEE-802.3:2005 1000Base-T
12	1	MDA-	2	IEEE-802.3:2005 1000Base-T
13	1	MDA+	1	IEEE-802.3:2005 1000Base-T
14	0 - 1	28 VDC	N/A	N/A
15	0	MDA+	1	IEEE-802.3:2005 1000Base-T
16	0	MDA-	2	IEEE-802.3:2005 1000Base-T
17	0	MDB+	3	IEEE-802.3:2005 1000Base-T
18	0	MDB-	6	IEEE-802.3:2005 1000Base-T

All other pins are NC.

DUAL PORT *TFOCA II® CONNECTOR, 100/1000BASE-T TO 100BASE-FX AND 1000BASE-SX MEDIA CONVERTER, MULTIMODE, 850 NM, 28 VDC

APPENDIX A1 PART NUMBER OPTIONS

TFOCA II Media Converter, Dual Port, Gigabit Ethernet / Multimode / 850 nM

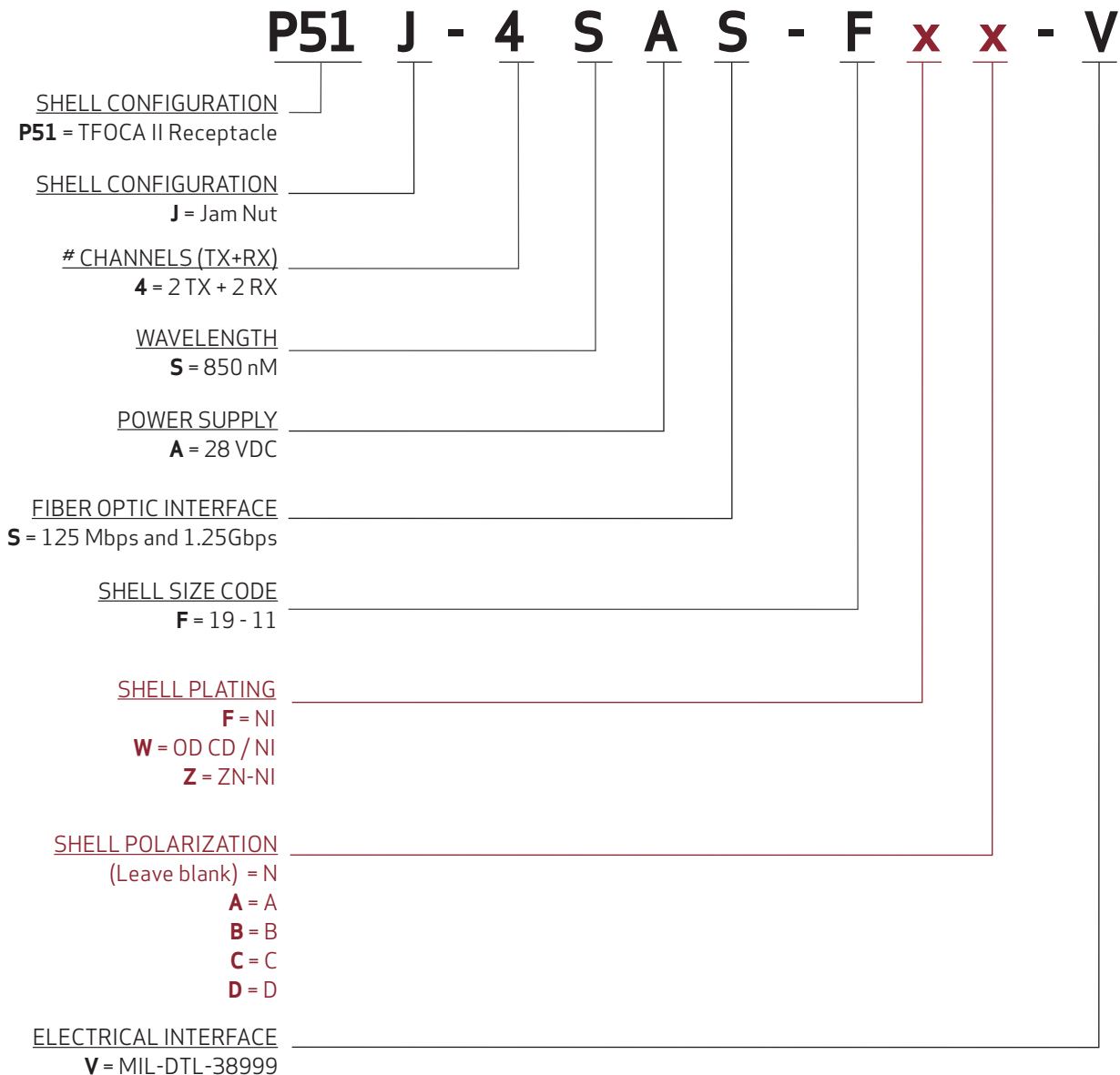

Other wavelength, mounting and port count options are available.
Please consult the Protokraft website for alternate configurations.



192 Bob Fitz Road, Johnson City, TN 37615
salesmp@moog.com
moogprotokraft.com