



MODEL 290 LINEAR SERVO ACTUATOR



The Model 290 is one of the highest performance linear servo actuators available on the market. We offer this actuator with a digital communications interface. It provides 1,500 lbf at 0.26 inches / second for up to 7.75 inch strokes. It has a homing sequence that determines end of travel on startup, thus, ensuring proper positioning along its stroke. These features allow our customer flexibility to have a drop-in servo actuator for their system.

TYPICAL APPLICATIONS

- Unmanned air vehicles — tactical, medium altitude, long endurance (MALE), and high altitude long endurance (HALE) vehicles
 - Flight control surface actuation
- Optionally piloted air vehicles (OPV)
- Utility actuation — throttle control, doors, spoilers
- Electric aircraft, eVTOL, eSTOL, air taxis and urban air mobility vehicles — propeller pitch control, tilting mechanism, flight control, landing gear



MODEL 290 LINEAR SERVO ACTUATOR

FEATURES

- Integrated position servo loop control utilizing Moog RS-485 digital communications protocol
- Non-jamming mechanical stops
- Stainless steel gear train
- Precision ball screw and nut assembly
- Brush-type permanent magnet motor design with integrated holding brake
- Electrical stops software controlled
- High resolution magnetic encoder
- Telemetry is composed of position, temperature, voltage and current
- Low latency
- Custom tunable performance parameters

BENEFITS

- Robust structural design
- Mechanical stops
- Low weight to power performance
- Customizable

ELECTRONICS DESIGN AND CONSTRUCTION

- IPC-6012, Class 3
- J-STD-001B, Class 3
- IPC-A-610, Class 3

*ENVIRONMENTAL SPECIFICATIONS

RTCA DO-160G Test

Description	Details
Operating Temperature	-40° to +71° C
Altitude	Up to 38,000 ft
Temperature and Altitude	Section 4, Category B1
Temperature Variation	Section 5, Category A
Humidity	Section 6, Up to 100% condensing
Power Input	Section 16, Category B, 28 VDC
Voltage Spike	Section 17
Waterproofness	Section 10, Category Y
Sand and Dust	Section 12, Category S
Random Vibration (Helicopter)	Section 8, Category U2
Operating Shock	Section 7, Category A
Salt Fog	Section 14
Induced Signal Susceptibility	Section 19
Radio Frequency Susceptibility	Section 20
Electrostatic Discharge (ESD)	Section 25, ≥ 2 kV pulse discharge

*Designed to meet these environmental specifications, testing not completed.

MODEL 290 LINEAR SERVO ACTUATOR

INPUT VOLTAGE / POWER DATA SPECIFICATIONS

Specification	Model 29000000-01
Operating Voltage	18 to 32 VDC
Weight	6.0 lb nom
Motor Type	24 VDC permanent magnet brush-type
Brake Type	24 VDC permanent magnet static
Output Shaft	Ball screw 0.2 inches / turn
Free Play	0.012 inches (0.3 mm) with 50 lbf
Mechanical Stroke	8.0 inches
Electrical Stroke	7.75 inches
No Load Current	800 mA
No Load Current with Brake	1.1 A
No Load Speed @ 28 VDC	0.6 inches / sec
Rated Current	5.75 A
Rated Torque and Speed	1,500 lbf (6,670 N) @ 0.26 inches / sec with a 10% duty cycle
Maximum Static Load	2,500 lbf (11,120 N)
Electrical Command Interface	Isolated half duplex RS-485 ²

Notes:

¹With ± 10 in-lbf reversing load applied to shaft.

²Contact Moog sales to receive detailed protocol information.

CONNECTOR PIN ASSIGNMENT

Pin Number	RS-485 Half Duplex Model 29000000-01	*Pin Diagram
1	RS-485A / interface I	<p>Shell size E (9 position)</p>
2	RS-485B / interface I	
3	RS-485 signal RTN	
4	+ 28 VDC	
5	Case Ground	
6	+ 28 VDC	
7	Power return	
8	Power return	
9	Spare	

*For reference only, Amphenol® catalog pin arrangement.

MODEL 290 LINEAR SERVO ACTUATOR

MECHANICAL DIMENSIONS (INCHES)

Note: 29000000-01 series shown

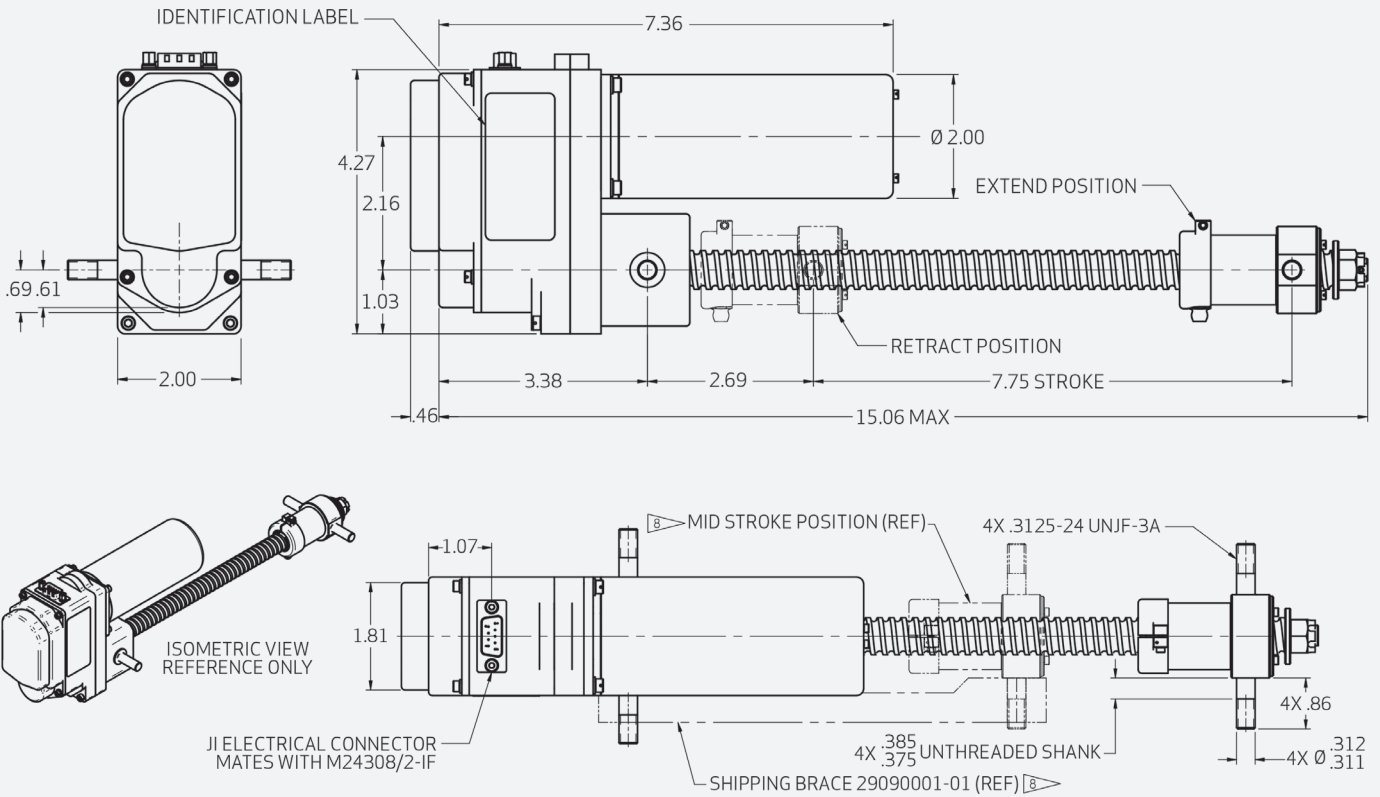

MOOG | Shaping the way our world moves™

poweranddata@moog.com
www.moog.com



Moog Space and Defense



Moog Inc.



@Moog_Inc



@Moog.Inc

Equipment described herein falls under the jurisdiction of the ITAR and requires US Government. Authorization for export purposes. Diversion contrary to US law is prohibited.

© 2026 a Moog company. All rights reserved.
Specifications and information are subject to change without prior notice.
Product and company names listed are trademarks or trade names of their respective companies.

Form 500-1297 051226