



MODEL AC7332 GIMBAL STAGE

ROTARY SINGLE-AXIS GIMBAL



Moog has taken their expertise in high-performance motion control components and elevated it in offering assemblies that combine many components into an integrated assembly. The single-axis gimbal stage combines our Matrix™ DC brushless direct drive motor and slip ring solutions with encoder, precision bearings and structure. Moog's gimbal stage is designed to support most payloads without the need for an external bearing system, thus

reducing set-up time, minimizing system space and weight, and simplifying the installation process. Install the rotary gimbal stage to your payload, connect a servo amplifier and source power, tune the stage per the instructions provided with the servo amplifier, and operate. Moog can recommend a source for servo amplifiers or provide a servo amplifier as an option. Stabilization options also available when purchased with Moog servo drive.

The gimbal stage's physical configuration includes a bore. This allows for the installation of either a RF rotary joint, fiber optic rotary joint, optics pass, air channel or other device for operation in various systems. Also the bore allows Moog to upgrade a fielded gimbal stage to pass multiple high-speed data channels as dictated by future system requirements without major redesign. For example, Moog can install a fiber optic rotary joint in the bore and provide data converters, media converters and/or multiplexers as a complete solution. This allows for easy and inexpensive upgrades, thus minimizing life cycle costs.

This gimbal stage is designed to be customized for unique applications without requiring major development expense. Moog has systems and components engineers in place to support your needs.



MODEL AC7332 ROTARY GIMBAL STAGE

FEATURES

- All rotary components are integrated into one assembly
- Moog's direct drive brushless DC motor provides excellent torque, heat transfer and life characteristics
- Use of Moog's drum style slip ring technology assure proper transfer of electrical power and data signals
- Rugged precision encoder that is well proven in many environments
- Bearing system and structure are designed to support typical customer payloads and vibration profiles
- Designed for harsh environments
- Wide dynamic performance range
- Bore allows for integration of fiber optic rotary joint, RF rotary joint, optics, additional slip ring or air channel pass
- Excellent slew to queue and slow tracking performance
- Standard with flying leads. Options include cable with connectors or connector assembly
- Shaft and face seals are included but optional to not install
- Position/velocity servo drive and stabilization options available

APPLICATIONS

- Electro-optical/infrared sensor suites
- Radar and lidar pedestals
- Active countermeasures systems
- Specialized assembly and automation
- Airborne, vehicular and stationary platforms
- Vision systems

BENEFITS

- Self-contained: easy installation
- Supports many payloads without the need for an external bearing set
- Reliable and maintainable
- Excellent performance in small size and light weight
- Adaptable for use with high data rate sensors via installation of a fiber optic rotary joint or second slip ring without the need to replace the rotary gimbal stage assembly

MODEL AC7332 ROTARY GIMBAL STAGE

SPECIFICATIONS

Parameter	Units	A	F	G	Notes
Motor Parameters					
Operational Temperature Range	°C	-54 to +71°C			Encoder screened to -54°C
Relative Humidity	Up to 95% noncondensing				
Peak Stall Torque	N-m (lb-ft)	10.3 (7.60)	21.9 (16.2)	10.3 (7.60)	
Continuous Stall Torque	N-m (lb-ft)	1.3 (0.959)	5.3 (3.91)	1.3 (0.959)	@ 71°C and mounted to customer's heat sink
Travel	360° continuous rotation				
Maximum Axial Load (Z-axis)*	N (lb)	1,112 (250)	1,112 (250)	1,112 (250)	
Maximum Radial Load (X and Y axis)	N (lb)	1,112N (250)	1,112 (250)	1,112N (250)	
Maximum Moment (X and Y axis)	N-m (lb-ft)	54 (40)	54 (40)	54 (40)	
Stage Mass	Kg (lb)	5.25 (11.5)	6.25 (13.75)	5.25 (11.5)	Not including payload
Stage Rotational Inertia	Kg-m ² (ft-lb-s ²)	.007 (.005)	.008 (.006)	.007 (.005)	
OD (Body)	mm (in)	172 (6.75)	172 (6.75)	172 (6.75)	
OD (Flange)	mm (in)	203.2 (8.000)	203.2 (8.000)	203.2 (8.000)	Alternate mounting configurations available, contact factory
ID	mm (in)	35.6 (1.4)	35.6 (1.4)	35.6 (1.4)	
Axial Length	mm (in)	76.2 (3.00)	89 (3.5)	76.2 (3.00)	
Motor Type	Direct drive 3-phase brushless DC				
Stall Voltage	VDC	22	30	22	3 Φ brushless to stage
Peak Current	ADC	20	20	20	3 Φ brushless to stage
Continuous Current (71°C)	ADC	5	5.3	5	3 Φ brushless to stage
Number of Poles		32	32	32	
DC Resistance	Ohms	1.10	1.50	1.10	\pm 10%
Torque Sensitivity***	lb.ft / amp	.439	0.875	0.439	\pm 10%
Back EMF Constant***	V per rad / s	.595	1.19	0.595	\pm 10%
Inductance	mH	1.0	2.2	1.0	
Approx. Seal and Bearing Torque	in-lb				
Encoder Parameters					
Type	Rotary optical absolute, BiSS-C 26-bit				Contact factory for other data formats
Accuracy	Static pointing accuracy at 25°C of 0.01 degrees				Contact factory for higher accuracy
Resolution	26-bit (67,108,864 counts per revolution)				18 and 32 bit also available contact factory for other resolutions
Slip Ring Parameters					
Passes (Number of Rings)		17 signal rings	17 signal rings and 2 power rings**	5 signal rings and 2 power rings	Total for power and data
Maximum Current	ADC	Signal rings: 2 amps	Power rings: 20 amps**	Power rings: 20 amps	Maximum continuous
Maximum Voltage	VDC	50	Power rings: 2 amps**	Power rings: 2 amps	
Data	Twisted pair leads and ring diameter supports high speed digital data such as gigabit Ethernet**				

Notes:

Performance parameters are based on numeric modeling and are subject to change. Tolerances will be provided once the configuration is finalized.

* Maximum axial load, maximum radial load in one direction and maximum moment applied simultaneously would result in a calculated L10 bearing life of 2×10^7 revolutions (-5,000 hours at 60 rpm).

** Example of F stage with 19 passes (rings):

- 2 power rings 20 A per ring
- 8 signal rings 1000BaseT Ethernet
- 4 signal rings RS-422
- 5 discrete / spare signal rings

***For frameless motor only: does not take into account friction torques of the assembly and seals.

Other options available:

1. Alternative input voltages are available by providing a motor with a different winding configuration than shown, as follows:

- Model A: Input stall voltages up to 96 volts, 3 Φ brushless
- Model F: Input stall voltages up to 144 volts, 3 Φ brushless
- Model G: Input stall voltages up to 96 volts, 3 Φ brushless

2. Slip ring variations are available within the number of passes shown, see ** above.
3. Output plate configurations to accept various payloads.
4. Bus voltage can exceed stall voltage provided it is less than 200 V and current limits are enforced.

MODEL AC7332 ROTARY GIMBAL STAGE

DIMENSIONS (INCHES)

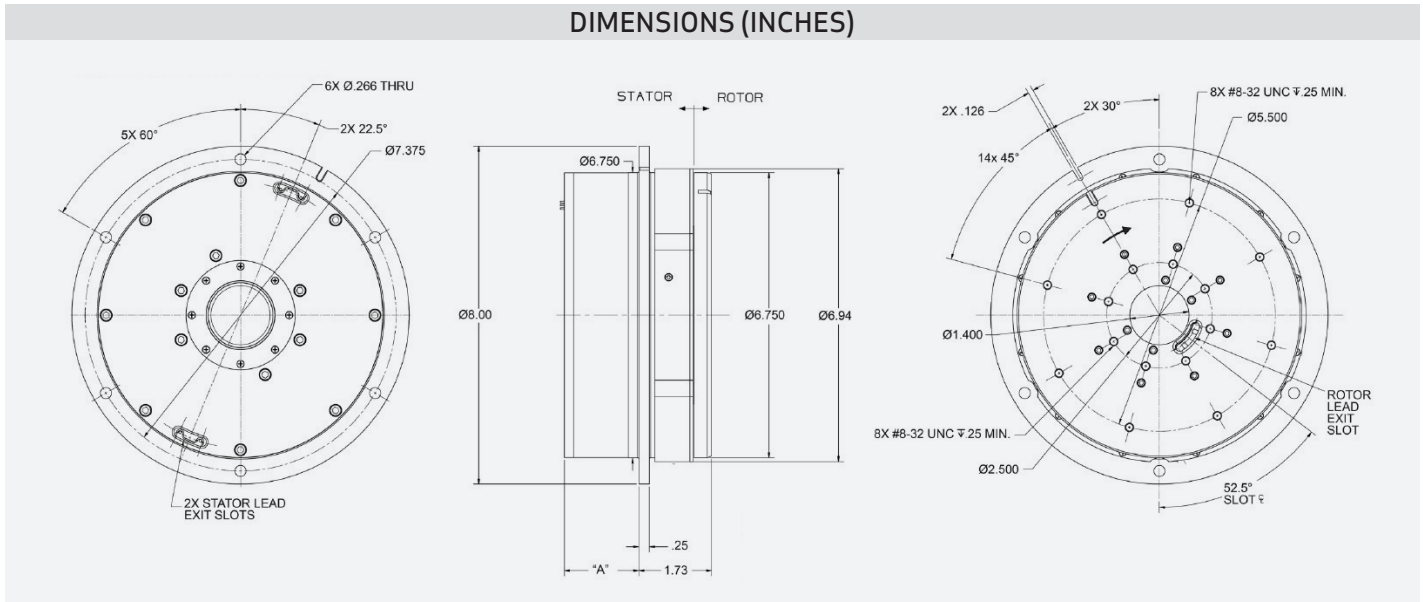

Stage Model	Dimension "A"
A	1.27 inches
F	1.77 inches
G	1.27 inches

STEPPING SEQUENCE

Step	Green	Orange	White
1	+		-
2	+	-	
3		-	+
4	-		+
5	-	+	
6		+	-

Notes:

- When the rotor and stator slots are aligned as shown the encoder output is approximately in the zero position.
- CW rotation of rotor as shown results in increasing encoder count.
- Motor stepping sequence results in CW rotation as shown

WIRING DIAGRAM (F STACK GIMBAL STAGE)

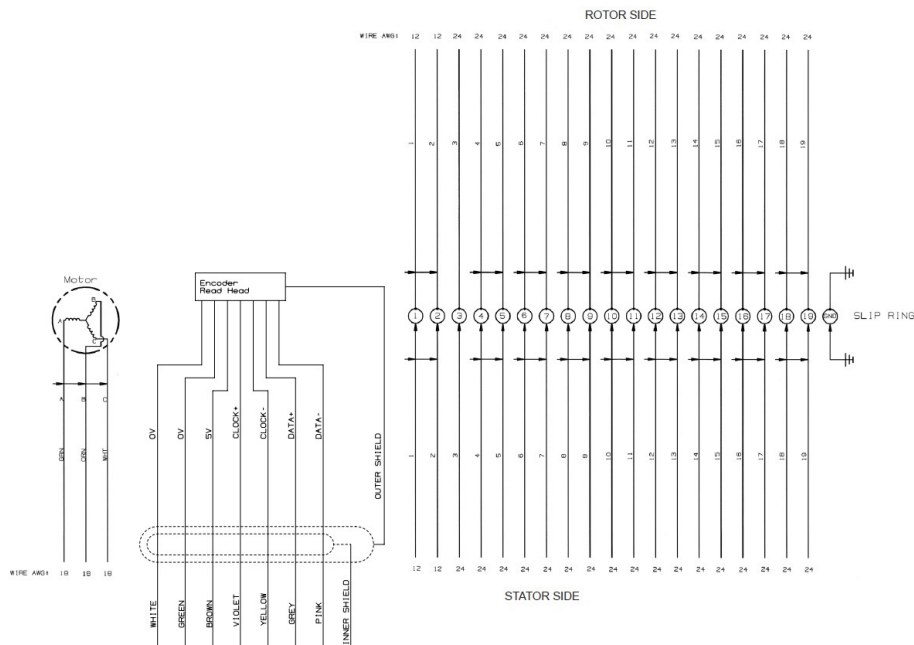

Notes:

- Ground inhibit (P3-6) to encoder OV (WHT, P2-8) to disable encoder and heater. Leave inhibit floating to enable.
- Encoder: ready (Brown lead P2-2) high indicates the encoder is powered on and ready. At temperatures below -40°C, the encoder will be heated for up to five minutes maximum before 5 V power is applied to the encoder. Heater power and encoder power are stepped down from 20 - 48 V raw bus power that is externally supplied.

MODEL AC7332 ROTARY GIMBAL STAGE

MODEL F, PERFORMANCE CURVES (@36 AND @71°C)

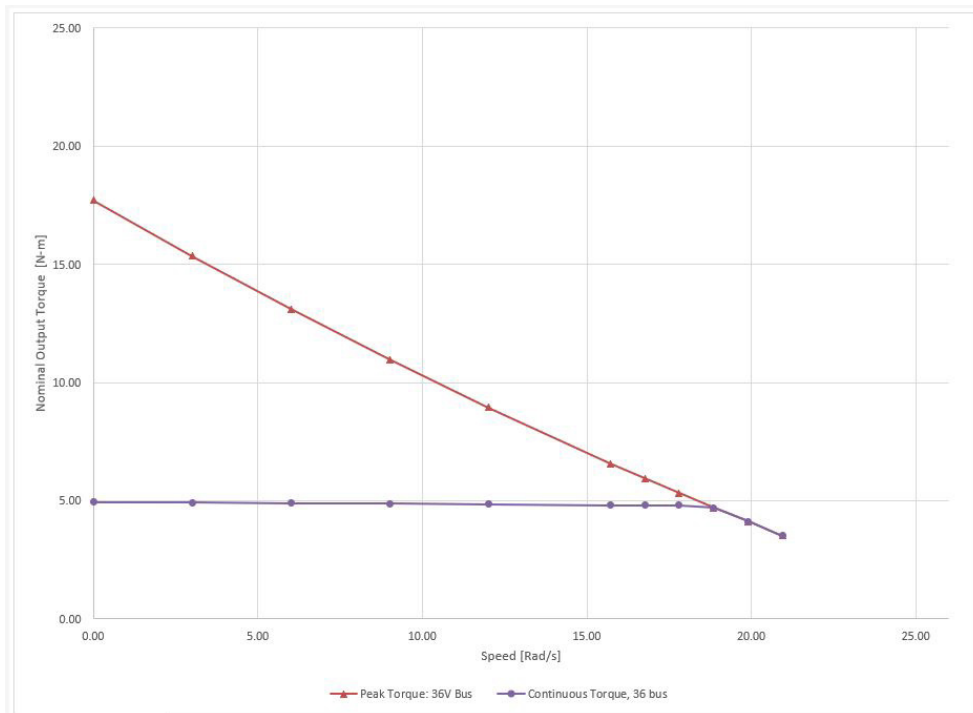

Notes:

1. Maximum current of 20 A. Continuous current of 6 A.
2. Payload assumption. Gimbal stage oriented with axis of rotation vertical and payload directly above or below stage.
3. Payload is equivalent to a 20 lb aluminum flywheel that is 9 inches in diameter and 3.25 inches thick with a mass moment of inertia of .06 kg-m².
4. Center of gravity (CG) is considered to be a maximum of 0.1 inches for the noted payload mass unless otherwise stated. Higher offset is allowable with a smaller payload mass.
5. Performance curves are based on numerical modeling and subject to change. Contact Moog to determine exact performance in your system.

MODEL F, STEP INPUT PERFORMANCE CURVES

20 lb typical payload, no external disturbances:

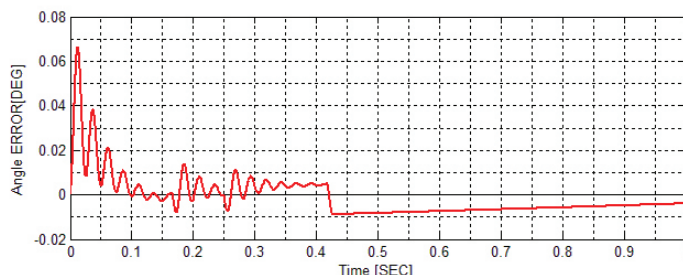
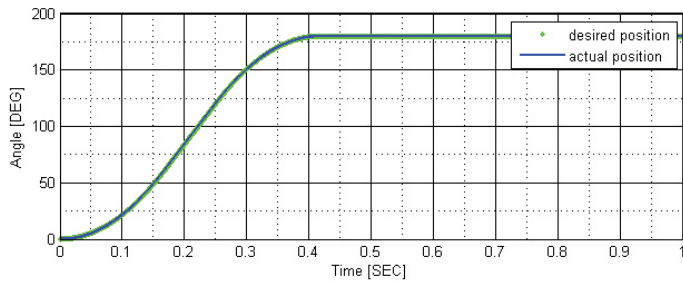

Maximum CG offset of 0.1 inches

20 lb typical payload, full helicopter disturbance:

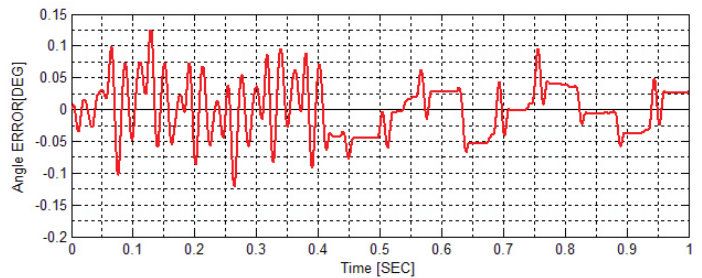
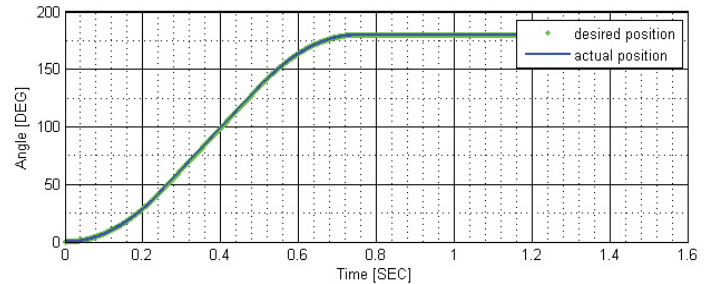

Maximum CG offset of 0.1 inches
.02 g²/Hz vibrate levels plus sine tones from a helicopter rotor

MODEL AC7332 ROTARY GIMBAL STAGE

MODEL A AND G, PERFORMANCE CURVES (@36 VDC AND @71°C)

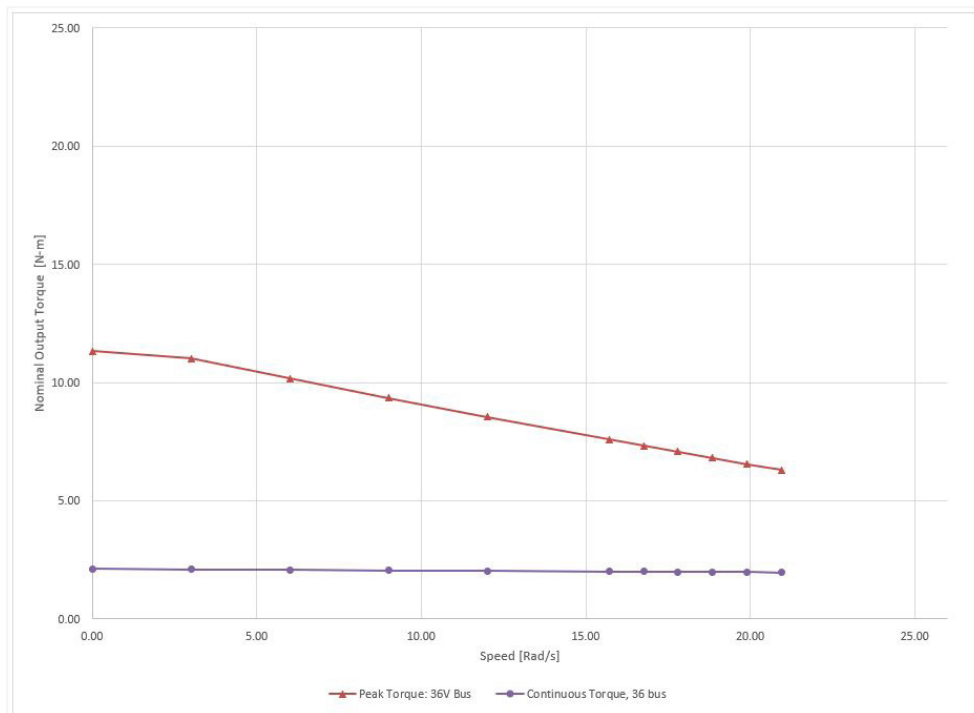

Notes:

1. Maximum current of 20 A. Continuous current of 5 A. Payload assumption. Gimbal stage oriented with axis of rotation vertical and payload directly above or below stage.
2. Payload is equivalent to a 20 lb aluminum flywheel that is 9 inches in diameter and 3.25 inches thick with a mass moment of inertia of .06 kg-m².
3. Center of gravity (CG) is considered to be a maximum of 0.1 inches for the noted payload mass unless otherwise stated. Higher offset is allowable with a smaller payload mass.
4. Performance curves are based on numerical modeling and subject to change. Contact Moog to determine exact performance in your system.

MODEL G, STEP INPUT PERFORMANCE CURVES

5 lb typical payload, no external disturbances:

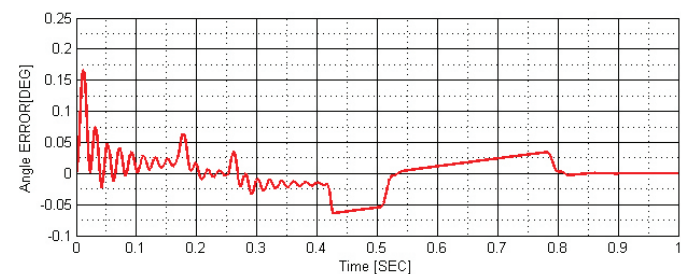
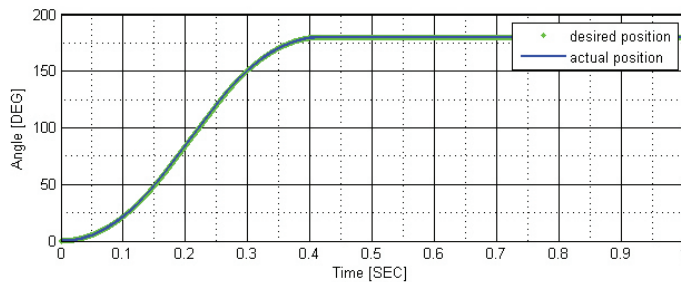

Maximum CG offset of 0.1 inches

20 lb typical payload, half helicopter disturbance:

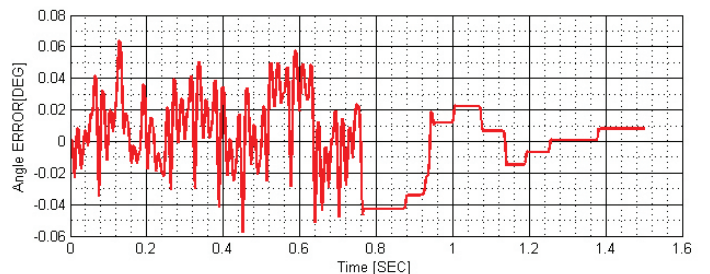
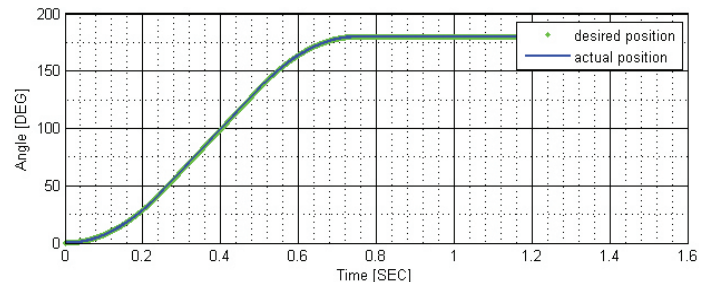

Maximum CG offset of 0.1 inches
.02 g²/Hz vibe levels plus sine tones from a helicopter rotor

MOOG | Shaping the way our world moves™

poweranddata@moog.com
www.moog.com



Moog Space and Defense



Moog Inc.



@Moog_Inc



@Moog.Inc

Products listed herein are subject to U.S. Export Regulations and may require export licensing. Contact Moog to obtain specific export control requirements.

© 2026 a Moog company. All rights reserved.
Specifications and information are subject to change without prior notice.
Product and company names listed are trademarks or trade names of their respective companies.