

HIGH TORQUE MOTORS

Delivering an integrated system based on a qualified architecture for high servo press productivity

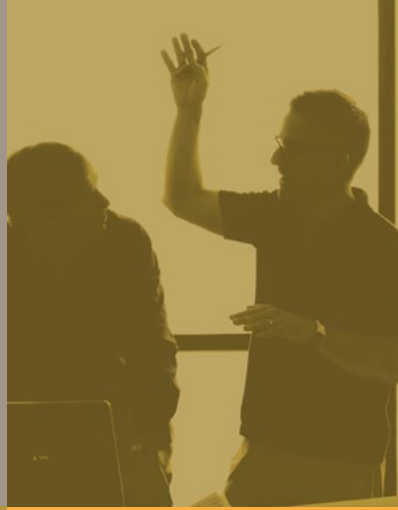

Customers seeking high throughput for next generation machines often experience challenges finding a qualified electro-mechanical solution with high dynamics, high torque and reliable operation. To help these customers, Moog is offering a new primary motion system for servo control from 139 kW to 1 MW with the highest dynamics in the industry, and an integrated system architecture that provides cost-saving energy management and higher productivity.

The result is a robust servo solution to help machine builders deliver high performance servo presses for 300 T and larger machines, with the advantages customers are seeking. Our design is based on our proven hardware and you can count on this qualified solution to operate reliably with minimal downtime.

Our integrated system consists of high power servo motors, servo drives, controllers, an energy management system, power supplies and software to transform electrical energy into motion. To minimize the time required to bring your new machine to market, our offering includes collaborative engineering support to help you simplify integration challenges and tools to facilitate quicker machine design and commissioning.

We know machine builders require flexibility so our system is customizable at both the product and system level. For example, our system architecture scales from 139 kW to 1 MW and we offer convection, fan-cooled and water-cooled options. You can count on our best-in-class products with high power and high dynamic performance to help you improve productivity, minimize downtime and bring your new machine to market faster.

ADVANTAGES

- High power and high dynamic servo motors provide high machine productivity
- Scalable system architecture, customizable hardware and collaborative engineering support reduce machine development time and increase flexibility
- Integrated system incorporates the latest energy management and motion control knowhow to provide your customers with world-class performance
- Collaborative global support from design to commissioning to aftermarket services includes tools (e.g., sizing, example design) and training to help your teams
- Qualified motion system with a supply chain able to meet your delivery time frames and uptime expectations

KEY APPLICATION MARKETS

- Servo press for automotive and industrial markets
- Marine deck machinery
- Industrial machinery
- Oil and gas exploration



Sizes 630 and 1,000 High Torque Motors for 300 T and Larger Servo Presses

SPECIFICATIONS

HTM 630 MOTOR - TECHNICAL DATA

Motor Length	G87	B010H (S)	B030H (S)	B011H (M)	B031H (M)	B012H (L)	B032H (L)
Cooling	---	Forced Air	Liquid	Forced Air	Liquid	Forced Air	Liquid
Peak Torque (M_{max})	Nm (lb-ft)	8,300 (6,122)		11,950 (8,814)		20,000 (14,752)	
Peak Power (P_{max})	kW (hp)	347 (465)	565 (757)	532 (712)	876 (1,173)	890 (1,192)	1,413 (1,894)
Peak Current (I_{max})	A_{rms}	781	1,250	1,250	2,080	2,140	3,200
Nominal Torque (M_{rat})	Nm (lb-ft)	2,130 (1,571)	2,815 (2,076)	3,350 (2,471)	4,475 (3,301)	5,615 (4,142)	7,910 (5,834)
Nominal Speed (n_N)	rpm	530	800	550	800	550	800
Nominal Current (I_N)	A_{rms}	200	425	340	760	585	1,180
Nominal Power (P_N)	kW (hp)	118 (158)	236 (316)	193 (258)	375 (502)	323 (433)	662 (887)
Continuous Stall Torque (M_{CS})	Nm (lb-ft)	2,940 (2,169)	3,965 (2,925)	4,625 (3,411)	6,200 (4,573)	7,350 (5,421)	10,475 (7,726)
Continuous Stall Current (I_{CS})	A_{rms}	275	600	470	1,060	770	1,660
Maximum Mech Speed (n_{mech})	rpm	1,200					
Voltage Constant (k_e)	Vrms/100rpm	73.1	45.7	67.6	40.6	65.8	43.8
Motor Weight	kg (lbs)	1,375 (3,031)	1,300 (2,866)	1,650 (3,638)	1,575 (3,472)	2,150 (4,740)	2,050 (4,520)
Inertia (J)	kg-m ² (lb-ft ²)	4.0 (95)		5.8 (138)		8.9 (211)	

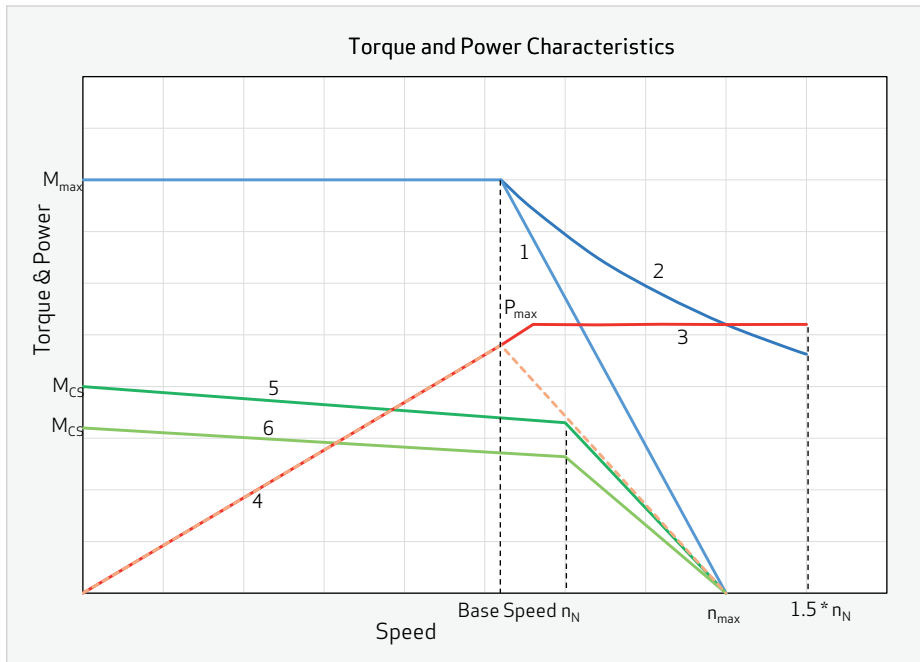

Notes:

- I. Performances are declared at 700VDC bus voltage.
- II. Contact Moog for different Lower and Higher Speed options.
- III. Performances are declared without Field weakening. Contact Moog for Field weakening performance.
- IV. Liquid cooled motor performances are declared at 25°C (77°F) water inlet temperature and 25 Liters/minute flow rate.
- V. Fan cooled motors performances are declared at 25°C (77°F) ambient temperature.

1. S2 Duty - NT Curve without Field Weakening (FW)
2. S2 Duty - NT Curve with FW
3. NP Curve with FW
4. NP Curve without FW
5. S1 Duty - Liquid Cooled
6. S1 Duty - Fan Cooled

DIMENSIONAL DETAILS

HTM 630 FAN COOLED

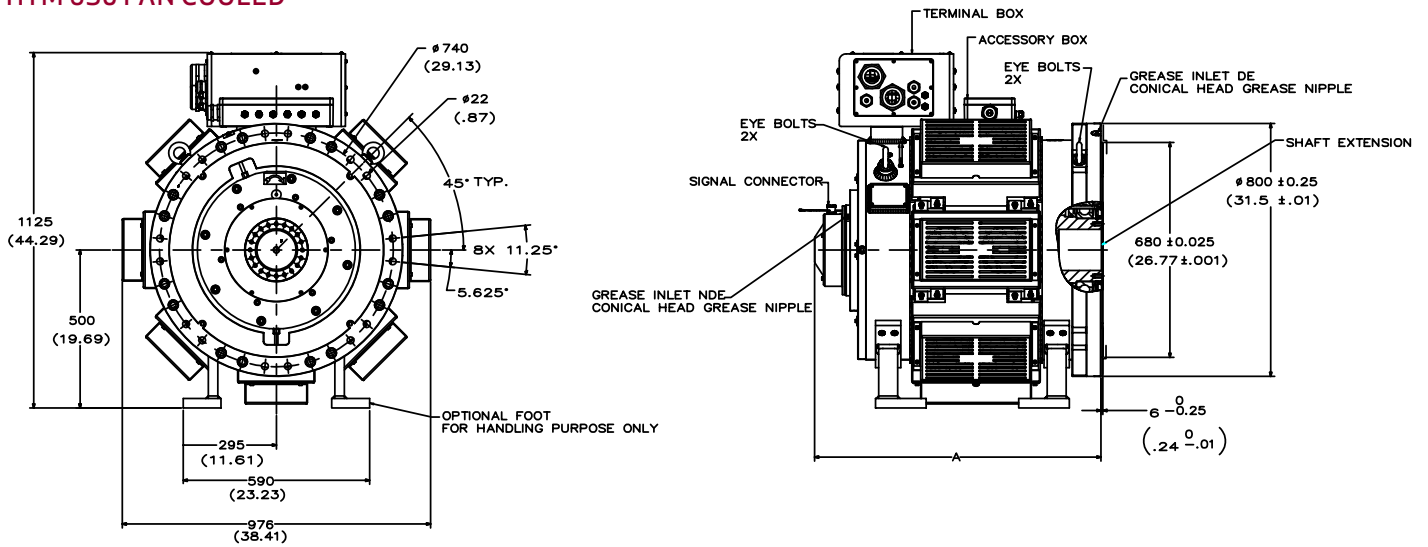

MODEL	A (mm (in))	SHAFT EXTENSION TYPES *
G87-B010H-XXX	792 (31.2)	Slot and Key, Plug On Shaft, Spline, Blind Hollow Shaft
G87-B011H-XXX	912 (35.9)	Slot and Key, Plug On Shaft, Spline, Blind Hollow Shaft
G87-B012H-XXX	1,142 (45.0)	Spline, Blind Hollow Shaft

* Contact Moog for more information on dimensional details

HTM 630 LIQUID COOLED

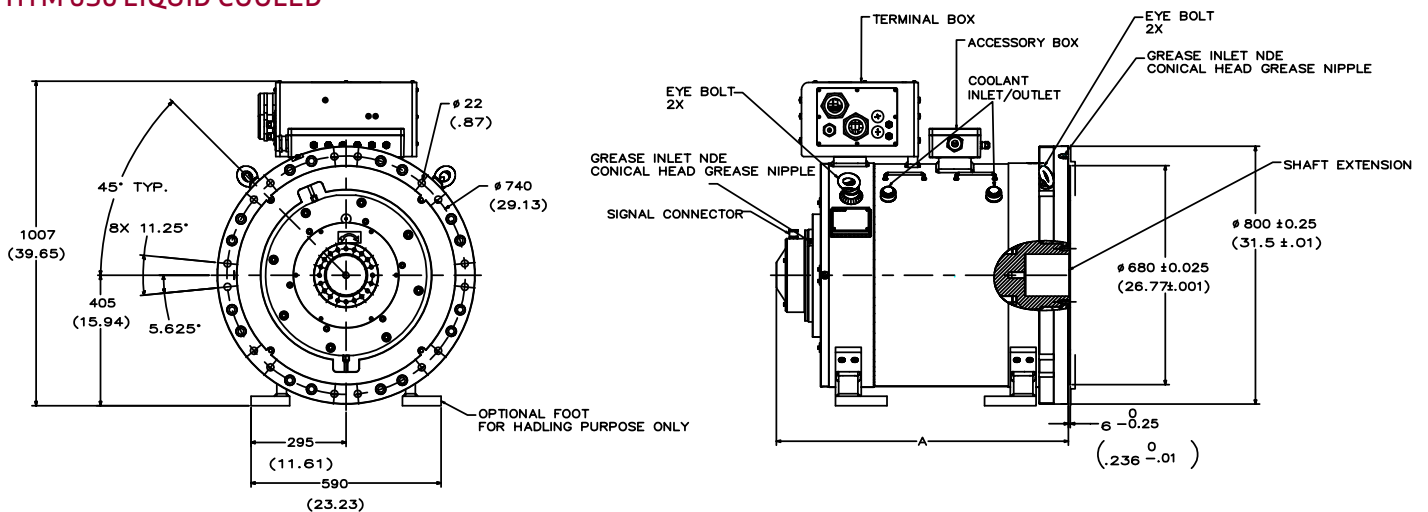

MODEL	A (mm (in))	SHAFT EXTENSION TYPES *
G87-B030H-XXX	792 (31.2)	Slot and Key, Plug On Shaft, Spline, Blind Hollow Shaft
G87-B031H-XXX	912 (35.9)	Slot and Key, Plug On Shaft, Spline, Blind Hollow Shaft
G87-B032H-XXX	1,142 (45.0)	Blind Hollow Shaft

* Contact Moog for more information on dimensional details

SPECIFICATIONS

HTM 1000 MOTOR - TECHNICAL DATA

Motor Length	G87-	C010H (S)	C030H (S)	C011H (M)	C031H (M)	C012H (L)	C032H (L)
Cooling	---	Forced Air	Liquid	Forced Air	Liquid	Forced Air	Liquid
Peak Torque (M_{max})	Nm (lb-ft)	28,000 (20,653)		50,000 (36,880)		70,250 (51,816)	
Peak Power (P_{max})	kW (hp)	821 (1,100)	1,085 (1,454)	1,440 (1,930)	1,728 (2,316)	2,097 (2,810)	2,796 (3,747)
Peak Current (I_{max})	A_{rms}	1,860	2,325	3,100	3,720	4,650	6,200
Nominal Torque (M_{rat})	Nm (lb-ft)	7,550 (5,569)	9,500 (7,007)	14,850 (10,953)	17,950 (13,240)	20,425 (15,065)	24,580 (18,130)
Nominal Speed (n_N)	rpm	360	450	340	425	360	450
Nominal Current (I_N)	A_{rms}	475	750	890	1,300	1,280	2,075
Nominal Power (P_N)	kW (hp)	285 (381)	448 (600)	529 (709)	799 (1,071)	770 (1,032)	1,158 (1,553)
Continuous Stall Torque (M_{CS})	Nm (lb-ft)	10,775 (7,431)	13,000 (9,589)	20,250 (14,936)	24,440 (18,027)	28,500 (21,021)	34,075 (25,133)
Continuous Stall Current (I_{CS})	A_{rms}	635	1,035	1,190	1,740	1,800	2,900
Maximum Mech Speed (n_{mech})	rpm	1,000					
Voltage Constant (k_E)	Vrms/100rpm	109.4	87.6	120	95.8	109.5	82.1
Motor Weight	kg (lbs)	3,330 (7,341)	3,230 (7,121)	4,400 (9,700)	4,300 (9,480)	5,475 (12,070)	5,375 (11,850)
Inertia (J)	kg-m ² (lb-ft ²)	26.4 (626)		43.4 (1,030)		60.6 (1,438)	

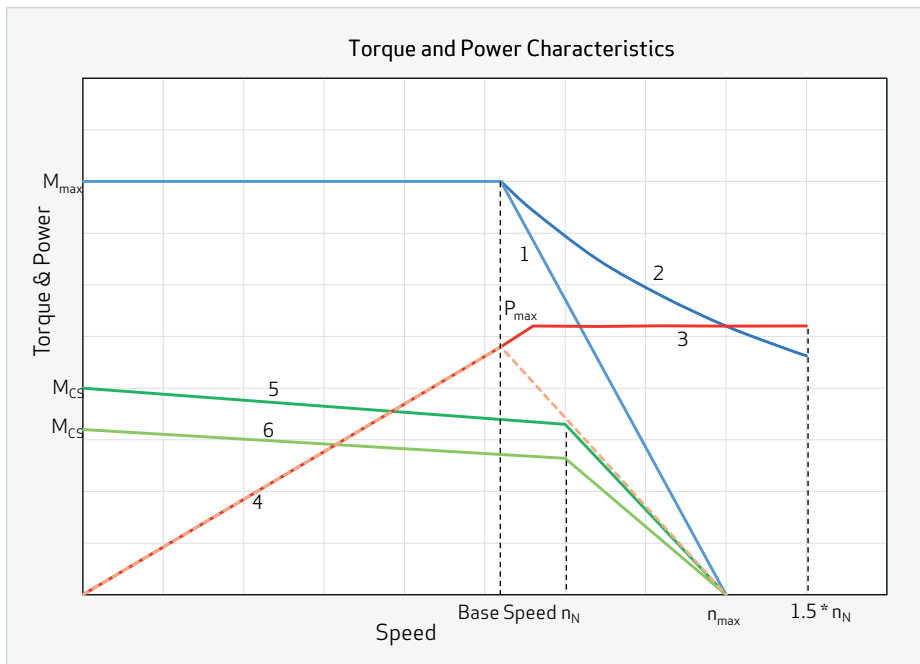

Notes:

- VI. Performances are declared at 700VDC bus voltage.
- VII. Contact Moog for different Lower and Higher Speed options.
- VIII. Performance are declared without Field weakening. Contact Moog for Field weakening performance.
- IX. Liquid cooled motor performances are declared at 25°C (77°F) water inlet temperature and 50 Liters/minute flow rate.
- IX. Fan cooled motors performances are declared at 25°C (77°F) ambient temperature.

- 1) S2 Duty - NT curve without Field Weakening (FW)
- 2) S2 Duty - NT curve with FW
- 3) NP curve with FW
- 4) NP curve without FW
- 5) S1 Duty - Liquid cooled
- 6) S1 Duty - Fan cooled

DIMENSIONAL DETAILS

HTM 1000 FAN COOLED

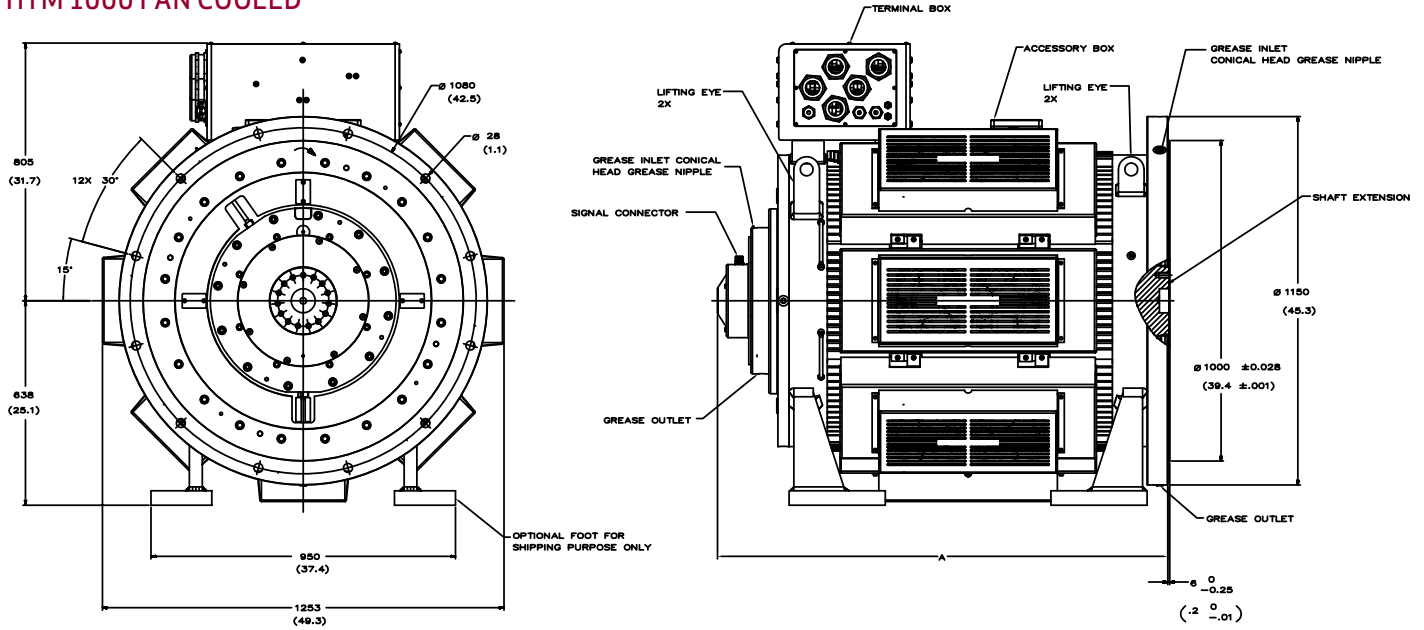

MODEL	A (mm (in))	SHAFT EXTENSION TYPES*
G87-C010H-XXX	1,115 (43.9)	Slot and Key, Plug On Shaft, Spline, Blind Hollow Shaft
G87-C011H-XXX	1,415 (55.7)	Slot and Key, Plug On Shaft, Spline, Blind Hollow Shaft
G87-C012H-XXX	1,715 (67.5)	Spline, Blind Hollow Shaft

* Contact Moog for more information on dimensional details

HTM 1000 LIQUID COOLED

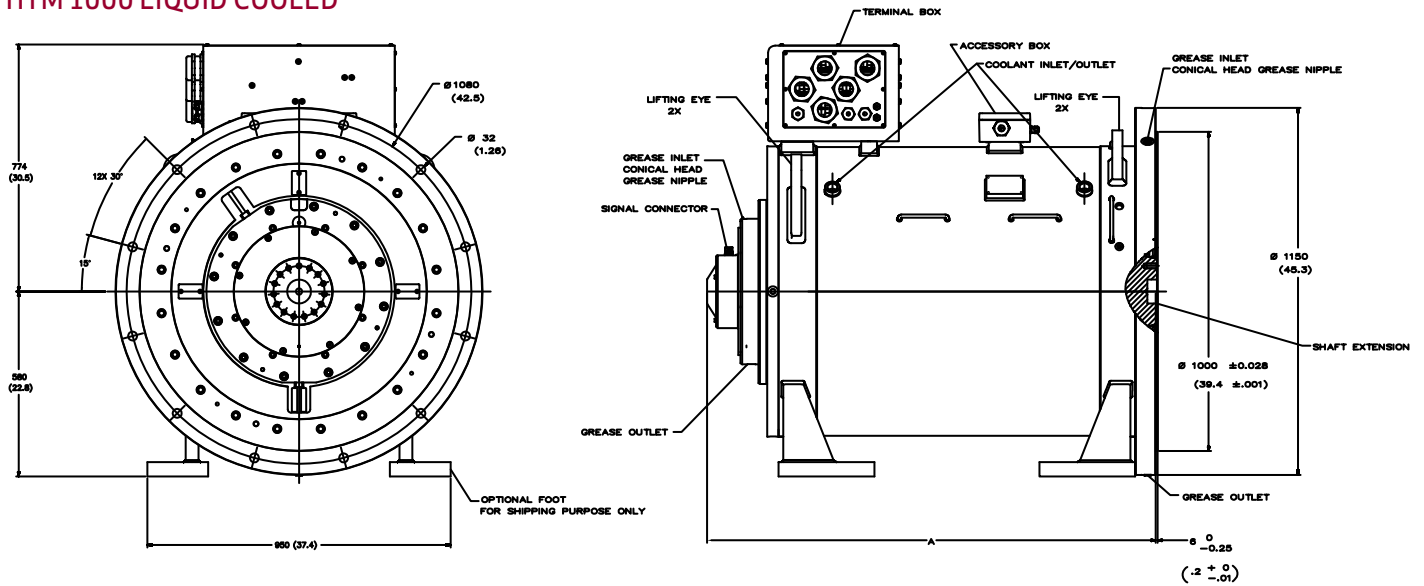

MODEL	A (mm (in))	SHAFT EXTENSION TYPES*
G87-C030H-XXX	1,115 (43.9)	Slot and Key, Plug On Shaft, Spline, Blind Hollow Shaft
G87-C031H-XXX	1,415 (55.7)	Slot and Key, Plug On Shaft, Spline, Blind Hollow Shaft
G87-C032H-XXX	1,715 (67.5)	Spline, Blind Hollow Shaft

* Contact Moog for more information on dimensional details

TURNKEY MOTION SYSTEM OPTIONS

The Moog Motion System is a proven turnkey, complete cabinet solution that enables flexible configurations to meet your exact needs. Robust liquid and forced air-cooled options are available as components or as separate slide out modules in integrated cabinet compartments.

A modular design approach offers flexibility in system configuration:

- Supports integration into hybrid systems with energy storage techniques to the DC-Link or AC-Grid.
- Servo drives with high peak and continuous current capabilities allowing peak current and high power to be achieved from standardised components in a single drive or in master/follower approach
- 16 fieldbus technologies are supported as modules, built in or mountable in the field for greater flexibility and ease of installation
- Tested and verified supply sections support active (AFE) and non-active (NFE) topologies with paralleling support within IUS cabinet sections
- Advanced safety functions implemented in accordance with the standard EN IEC 61800-5-2 with an optional board to handle safe I/O and the monitoring of active safety functions across the entire hardware base

In addition, Moog's simulation suite and digital commissioning techniques help you achieve predictable and optimized system performance.



System Components Ranges	Air Cooled	Liquid Cooled
Servo Drive Range	1kW to 1,200kW	11kW to 5,150kW
Active front End Range	45kW to 3,300kW	129kW to 1,762kW
Brake Chopper Range	6kW to 2,300kW	37kW to 833kW

Standard Component Ratings		
Input Voltage U _{in} , Output Voltage	400 to 500 VAC (-10% to +10%) 465 to 800 VDC (-0% to +0%)	0 to U _{in}
Input Frequency, Output Frequency	45 to 66 Hz	0 to 320 Hz
Control Method - Servo Drive	Frequency control U/f Open loop speed & torque control Closed loop speed and torque control	
Vibration EN50178/EN60068-2-6	5 to 150 Hz Displacement amplitude 0,25 mm (peak) at 5 to 15.8 Hz Max acceleration amplitude 1 G at 15.8 to 150 Hz	
Shock EN50178 EN60068-2-27	UPS Drop Test (for applicable UPS weights) Storage and shipping: max. 15 G, 11ms (in package)	
Enclosure class	IP 00 standard	
Immunity, Emissions	Fulfil all EMC standards	
Safety	EN 50178, EN 60204-1, IEC 61800-5-1, CE, UL, CUL	
Functional Safety	Safety integrity level (SIL) (IEC 61508) up to SIL3 Profisafe communication over Profibus	
	<ul style="list-style-type: none"> • Safe Torque Off (STO) • Safe Stop 1 (SS1) • Safe Stop 2 (SS2) • Safe Operating Stop (SOS) 	<ul style="list-style-type: none"> • Safe Brake Control (SBC) • Safe Limited Speed (SLS) • Safe Speed Range (SSR) • Safe Speed Monitor (SSM)
Analogue input voltage	0 to +10V, R _i = 200k Ω , (-10V to +10V joystick control) Resolution 0.1%, accuracy \pm 1%	
Analogue output	0(4) to 20mA, R _L max. 500 Ω , Resolution 10bit, Accuracy \pm 2%	
Digital inputs (6), Digital outputs	Positive or negative logic, 18 to 30VDC	Open collector output, 50mA/48V
Overvoltage Trip limit	911Vdc	
Relay Outputs	2 programmable change-over relay outputs Switching capacity 24VDC/8A, 250VAC/8A, 125VDC/0.4A Min. switching load: 5V/10mA	
Protections	Overvoltage, undervoltage, earth fault, mains supervision, motor phase supervision, overcurrent, unit overtemperature, motor overload, motor stall, motor underload, short-circuit of +24 V and +10 V reference voltages	

MOOG GLOBAL SUPPORT

Moog Global Support is our promise to use a dynamic and collaborative approach to help you solve your machine challenges. Whether you are developing a new generation machine or need ideas and support for an existing design, it reflects our commitment to keeping your motion control products and systems running at peak performance by providing responsive support. Around the globe in 25 countries, local teams of trained Moog technicians are on standby with the services you need from express repairs to exchange programs, and on-site technical support.

The range of services we offer is extensive to match your needs, your industry and the technology of your product. Our commitment to you goes beyond the initial collaboration and involves a thorough understanding of your application, your technical needs and your overall objectives. Global Support is as reliable and flexible as our products.

Moog provides tools to support the design and commissioning of your machines and by working together we minimize the time to bring new machines to market.

- Our global onsite commissioning support teams will be there when you need them
- We will ensure your engineers have the knowledge to apply large power servo systems through our specialized training
- Global presence with support available in person and through our online portals
- Local sales and applications engineering teams are trained to apply HTM and are ready to work with you

Visit www.moogglobalsupport.com to find a service center near you.



WORKING TOGETHER FOR MAXIMUM PRODUCTIVITY

A Korean manufacturer of mechanical metal forming presses ranging from 100 T to 1,200 T was seeking to develop its first electric Servo Press. The driver was the introduction of high strength steels and alloys into the auto industry, requiring the use of servo control technology in mechanical presses to prevent fatigue initiation sites in the formed parts.

The Request

Develop an electrical solution that provides full servo motion control of the Servo Press while delivering 1,200 T of force at 30 strokes per minute. The system must manage energy transfer from the power grid and store energy to deliver peak power.

The Solution

Moog leveraged its scalable motion control architecture and high power servo motors to deliver a



solution to the customer that manages up to 2 MW of instantaneous power, and provides full motion control of the Servo Press. Our engineers worked closely with the customer during the design phase of the machine, sharing electrical schematics and power management strategies with the customer's engineering team.

Moog's high power Servo Motors have the highest dynamic response in the industry, enabling the machine productivity to be maximized and achieve the target of 30 strokes per minute.

The Result

By closely collaborating with our customers from design through commissioning, the development time for the machine was reduced and the customer was able to introduce a new range of Servo Press Machines with minimal commercial risk.

ENERGY MANAGEMENT STRUCTURE

ENERGY MANAGEMENT STRUCTURE TO REDUCE THE COST OF ENERGY IN YOUR MACHINE

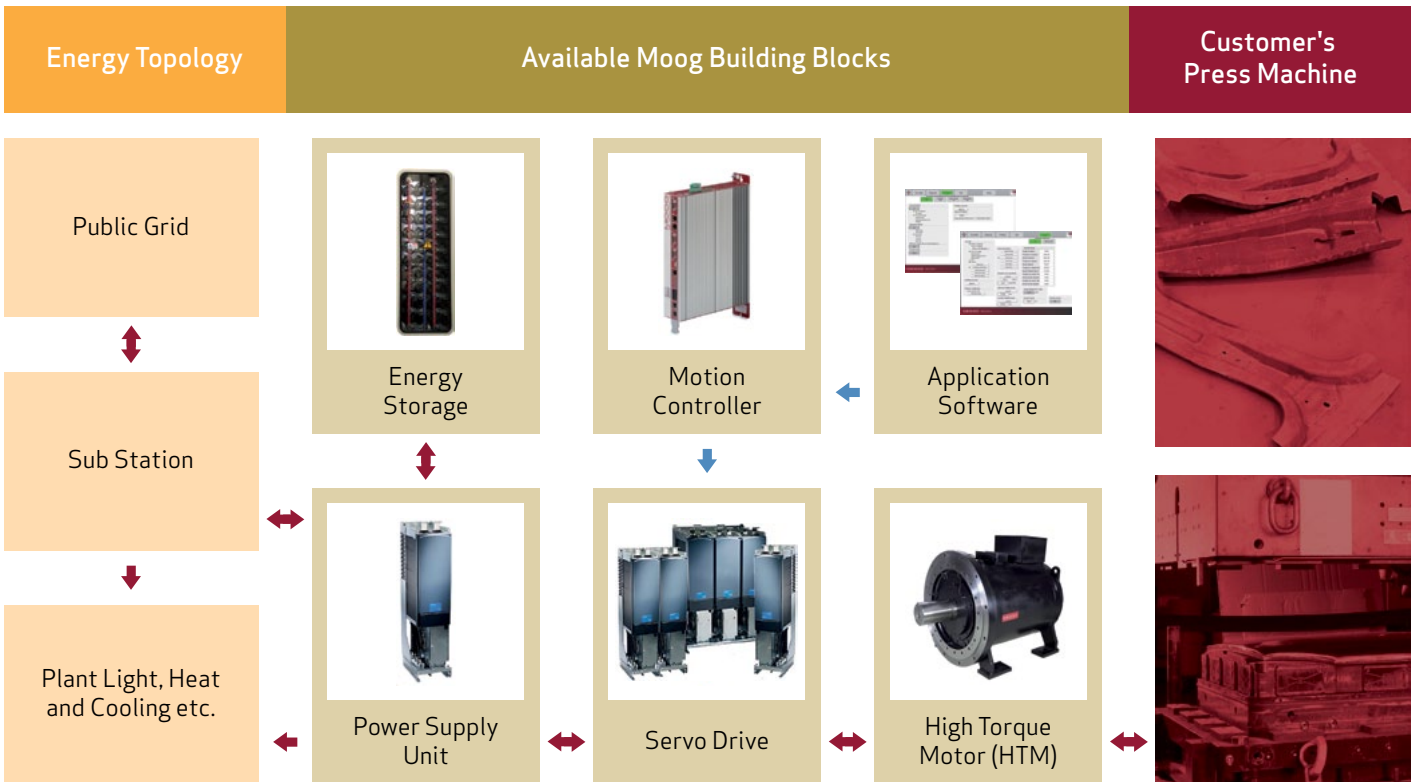

- Flow of Energy and Regenerative Energy
- Flow of Control Signal

The local energy management system that Moog has designed for the High Torque Motor has two primary benefits for customers:

- Minimizes the energy requirements from the public network to save energy costs
- Provides the highest dynamic performance for higher productivity and smooth operation for better finished part quality

The advanced regenerative power supply designed by Moog engineers meets the energy requirements of a modern servo press and enables customers to recover energy from the system. The recovered energy can be used in other parts of the facility or returned to the public network (Grid), providing significant energy cost savings.

Moog's dedicated servo press application software has 13 motion types and six operation modes with motion derived from position, speed and time. An integrated jerk control strategy guarantees smooth operation throughout the movement of the servo press. The application software in combination with the motion controller and servo drive provide the optimum use of energy with the highest performance possible.

Find out how our motion control expertise and world class products, solutions and services can help solve your machine challenges.

Moog has offices around the world. For more information or the office nearest you, contact us online.

info@moog.com

For product information, visit

moog.com/industrial

For service information, visit

moogglobalsupport.com

Moog is a registered trademark of Moog Inc. and its subsidiaries. All trademarks as indicated herein are the property of Moog Inc. and its subsidiaries. ©2019 Moog Inc. All rights reserved. All changes are reserved.

HTM Series Servo Motor
Laasner/Rev. D, October 2019 CDL49471-en

This technical data is based on current available information and is subject to change at any time. Specifications for specific systems or applications may vary.

MOOG