

mda.mil



U.S. Navy



U.S. Army photo by
Spc. Hubert D. Delany III

TYPE 30 NOZZLE-FLAPPER FLOW CONTROL SERVO VALVES

CATALOG

TYPE 30

NOZZLE-FLAPPER SERVO VALVES

- Flow Control
- Two Stage
- Double Nozzle
- Mechanical Feedback

Five Basic Sizes

		PORT CIRCLE DIAMETER		MAX RATED FLOW		VALVE WEIGHT	
		in	mm	gpm at 3000 psi	liters/min at 210 bars	lbs	kg
TYPE 30 SERVO VALVES	Series 30	0.480	12.19	3.1	12	0.42	0.19
	Series 31	0.625	15.88	6.8	26	0.81	0.37
	Series 32	0.780	19.81	14.0	54	0.81	0.37
	Series 34	0.780	19.81	19.0	73	1.10	0.50
	Series 35	1.000	25.40	44.0	170	2.13	0.97

This Catalog Contains

- General information on Type 30 servo valves
- Information on standard valve designs

Standard Designs

- Are assembled from standard parts
- Offer choice of
 - rated flow
 - rated pressure
 - rated current (coil resistance)
 - internal coil connection
 - electrical connector or cable
 - connector or cable location
 - seal compound
- give standard performance (per Moog specification)
- eliminate non-recurring start-up costs

Position Servo -

The Usual Application of Flow Control Servo valves

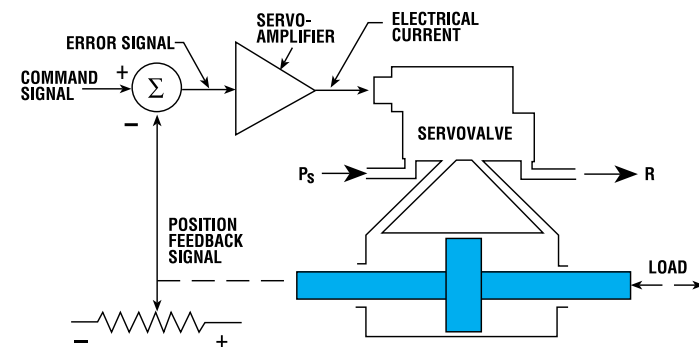

- Servo valve supplied with constant pressure P_s (e.g., 3000 psi or 210 bars)
- Servo valve controls flow to and from piston end chambers in response to electrical signal
- Piston drives load
- Position feedback signal obtained from pot, LVDT, DCDT, etc.
- Difference between position **command signal** and position **feedback signal** is **error signal**
- Error signal is amplified to drive servo valve
- Load moves to reduce error to near zero

DESIGN FEATURES

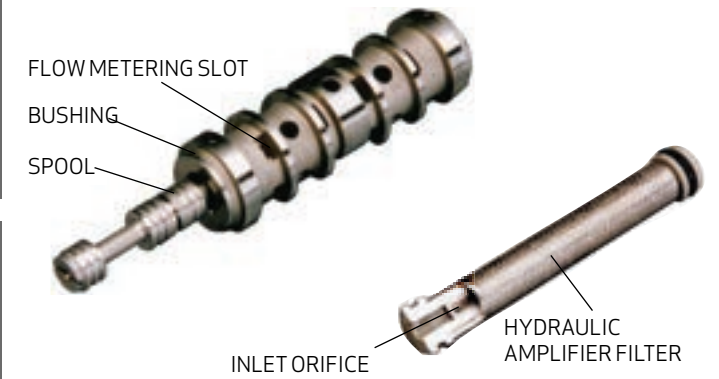
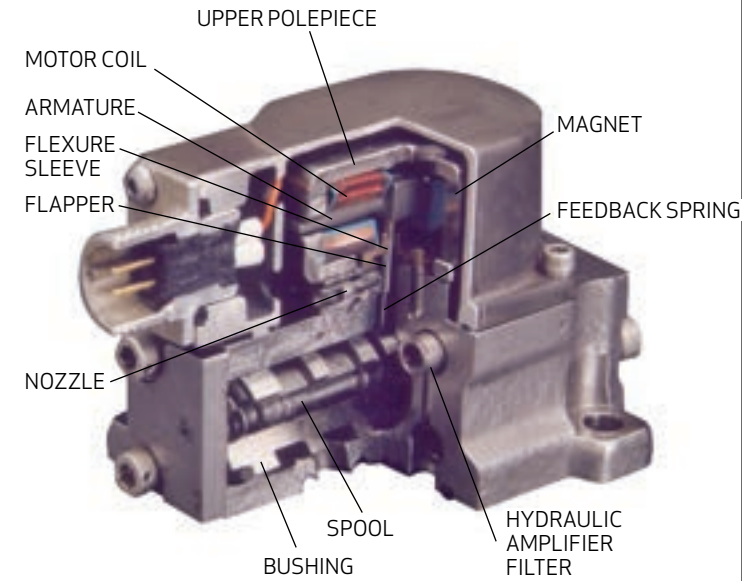

Materials used in Standard Type 30 Servo valves

Body*	Stainless steel
End caps	Stainless steel
Spool and bushing*	Stainless steel
Filter (35 micron absolute)	Sintered stainless steel wire mesh
Flexure sleeve	Beryllium copper
Polepieces and armature	Nickel-iron steel
Magnets	Alnico alloy
Feedback spring	Stainless steel
Torque motor cover	Anodized aluminum alloy

*The Series 30 has an integral bushing and body made from stainless steel

- Rugged, stainless steel body
 - One-piece bushing with EDM flow slots*
- Bushing slip-fit in body bore
 - eliminates bushing and O-rings
 - bushing easily removed for cleaning or replacement
- O-ring sealed spool stops
 - eliminates pressure loading of ends of bushing
- Spool bushing tolerances for diametral clearance held within 20 microinches ($\frac{1}{2} \mu\text{m}$)
- 20 μm nominal filter (35 μm absolute) for pilot flow
- Symmetrical, double nozzle hydraulic amplifier
 - provides consistent performance over wide temperature range
- Hydraulic amplifier integrated into main valve body
 - eliminates several O-rings
- Torque motor in environmentally sealed compartment
 - Frictionless, flexure sleeve supported armature/flapper
 - isolates hydraulic fluid from torque motor
- Balanced, double coil, double air gap torque motor
 - reduces temperature centershift
 - minimizes external magnetic fields
 - reduces sensitivity to external magnetic materials or fields
- Motor coils have resilient potting
 - cushions coils during thermal and vibration extremes
- Mechanical feedback with simple cantilever spring
 - rolling ball contact with spool minimizes wear
 - feedback removable without damage to valve

Environmental Capability of Standard Designs*

- Meet or exceed SAE ARP 490
- Suitable for Type I and II missile and aircraft hydraulic systems per SAE AS 8775
 - Type I -65°F to +160°F (-54°C to +71°C)
 - Type II -65°F to +275°F (-54°C to +135°C)
- Meet or exceed the following as tested per MIL-STD-810
 - **high temperature** - normal performance at +275°F fluid and ambient with MIL-PRF-5606 fluid (***NOTE: leakage will vary with temperature**)
 - **low temperature** - normal performance at 0°F fluid and ambient with MIL-PRF-5606 fluid
 - **extreme low temperature** - valves will respond to input commands at -65°F fluid and ambient on MIL-PRF-5606 fluid
 - **altitude** - normal performance to 100,000 feet altitude
 - **random vibration** - will withstand 25 g rms (5 to 2000 Hz) 30 minutes per axis
 - **sinusoidal vibration** - will withstand sweep from 16 g at 25 Hz, to 35 g at 2000 Hz, 30 minutes per axis
 - **acceleration** - will withstand 50 g any axis
 - **shock** - will withstand 6 msec sawtooth, 100 g peak, any axis
 - **salt spray, fungus, humidity, sand and dust** - will withstand all exposures per MIL-STD-810
 - **useful life** - >10 years with normal overhaul
 - **cyclic life** - > 10^7 cycles with normal wear

Please contact Moog for a complete environmental capabilities overview on servo valve technology.

*EDM = electric discharge machined
Series 30 does not have a bushing (slots are EDM'd in valve body).

TERMINOLOGY

Per SAE ARP 490

See Moog Technical Bulletin No. 117 for a complete discussion of servo valve terminology and test techniques.

Electrical

Input Current - The electrical current to the valve which commands control flow, expressed in milliamperes (ma).

Rated Current - The specified input of either polarity to produce rated flow, expressed in milliamperes (ma). Rated current is specified for a particular coil configuration (differential, series, individual or parallel coils) and does not include null bias current.

Quiescent Current - A dc current that is present in each valve coil when using a differential coil connection. The polarity of the current in the two coils is reversed so that no net signal input exists.

Coil Impedance - The complex ratio of coil voltage to coil current. Coil impedance will vary with signal frequency, amplitude, and other operating conditions, but can be approximated by the dc coil resistance (R ohms) and the apparent coil inductance (L henrys) measured at a signal frequency.

Dither - An ac signal sometimes superimposed on the servo valve input to improve system resolution. Dither is expressed by the dither frequency (Hz) and the peak-to-peak dither current amplitude (ma).

Hydraulic

Control Flow Q_v - The flow through the valve control ports to the load expressed in in³/sec (cis), gal/min (gpm), liters/min (lpm) or for fuel applications lbs/hr (pph).

Rated Flow Q_R - The specified control flow corresponding to rated current and given supply and load pressure conditions. Rated flow is normally specified as the no-load flow and is expressed in cis, gpm, lpm or pph.

Flow Gain - The nominal relationship of control flow to input current, expressed as cis/ma, gpm/ma, lpm/ma or pph/ma.

No Load Flow - The control flow with zero load pressure drop, expressed in cis, gpm, lpm or pph.

Internal Leakage - The total internal valve flow from pressure to return with zero control flow (usually measured with control ports blocked), expressed in cis, gpm, lpm or pph. Leakage flow will vary with input current, generally being a maximum at the valve null (called null leakage).

Load Pressure Drop ΔP_L - The differential pressure between the control ports (that is, across the load actuator), expressed in lbs/in² (psi), or bars.

Valve Pressure Drop ΔP_v - The sum of the differential pressures across the control orifices of the servo valve spool, expressed in psi or bars. Valve pressure drop will equal the supply pressure, minus the return pressure, minus the load pressure drop. [$\Delta P_v = (P_s - R) - \Delta P_L$]

TERMINOLOGY

Per SAE ARP 490

See Moog Technical Bulletin No. 117 for a complete discussion of servo valve terminology and test techniques.

Performance

Linearity - The maximum deviation of control flow from the best straight line of flow gain. Expressed as percent of rated current.

Symmetry - The degree of equality between the flow gain of one polarity and that of reversed polarity, measured as the difference in flow gain for each polarity and expressed as percent of the greater.

Hysteresis - The difference in valve input currents required to produce the same valve output as the valve is slowly cycled between plus and minus rated current. Expressed as percent of rated current.

Threshold - The increment of input current required to produce a change in valve output. Valve threshold is usually measured as the current increment required to change from an increasing output to a decreasing output. Expressed as percent of rated current.

Lap - In a sliding spool valve, the relative axial position relationship between the fixed and movable flow-metering edges with the spool at null. Lap is measured as the total separation at zero flow of straight line extensions of the nearly straight portions of the flow curve, drawn separately for each polarity. Expressed as percent of rated current.

Pressure Gain - The change of load pressure drop with input current and zero control flow (control ports blocked). Expressed as nominal psi/a or bars/ma throughout the range of load pressure between ±40% supply pressure.

Null - The condition where the valve supplies zero control flow at zero load pressure drop.

Null Bias - The input current required to bring the valve to null, excluding the effects of valve hysteresis. Expressed as percent of rated current.

Null Shift - The change in null bias resulting from changes in operating conditions or environment. Expressed as percent of rated current.

Frequency Response - The relationship of no-load control flow to input current when the current is made to vary sinusoidally at constant amplitude over a range of frequencies. Frequency response is expressed by the amplitude ratio (in decibels), and phase angle (in degrees), over a specific frequency range.

Units

Recommended English and Metric units for expressing servo valve performance include the following:

*JP-4 and JP-5 jet fuel

	English	Metric	Conversion
Fluid Flow	in ³ /sec (cis)	Liters/min (lpm)	0.98 lpm/cis
			100.1 pph/cis*
	gal/min (gpm)		3.78 lpm/gpm
Fluid Pressure	lb/in ² (psi)	bars	0.069 bars/psi
Dimensions	inches (in)	millimeters (mm)	25.4 mm/in
		micrometers (μm)	25400 μm/in
Weight	pounds (lb)	kilograms (kg)	0.454 kg/lb
Force	pounds (lb)	Newtons (N)	4.45 N/lb
Torque	in-lb	Newton meters (N-m)	0.113 N-m/in-lb
Temperature	degrees Fahrenheit (°F)	degrees Celsius (°C)	°C=5/9 (°F-32)

OPERATION

Torque Motor

- Charged permanent magnets polarize polepieces
- DC current in coils causes increased force in diagonally opposite air gaps
- Magnetic charge level sets magnitude of decentering force gradient on armature

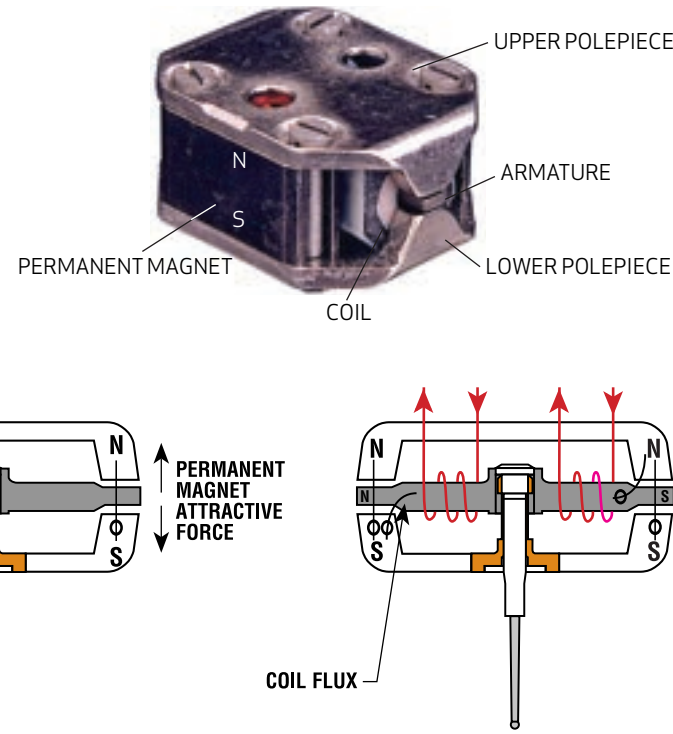

Operation

- Electrical current in torque motor coils creates magnetic forces on ends of armature
- Armature and flapper assembly rotates about flexure sleeve support
- Flapper closes off one nozzle and diverts flow to that end of spool
- Spool moves and opens P_s to one control port; opens other control port to R

Hydraulic Amplifier

- Armature and flapper rigidly joined and supported by thin-wall flexure sleeve
- Fluid continuously flows from pressure P_s , through both inlet orifices, past nozzles into flapper chamber, through drain orifice to return R
- Rocking motion of armature/flapper throttles flow through one nozzle or the other
- This diverts flow to A or B (or builds up pressure if A and B are blocked)

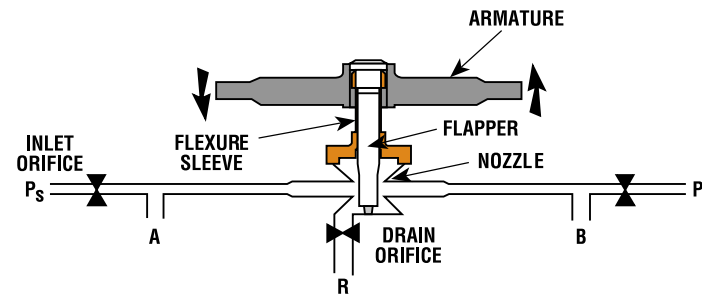

Valve Spool

- Spool slides in bushing (sleeve), or directly in body bore for Series 30
- Bushing contains rectangular holes (slots) or annular grooves that connect to supply pressure P_s and return R
- At "null" spool is centered in bushing; spool lobes (lands) just cover P_s and R openings
- Spool motion to either side of null allows fluid to flow from P_s to one control port, and from other control port to R

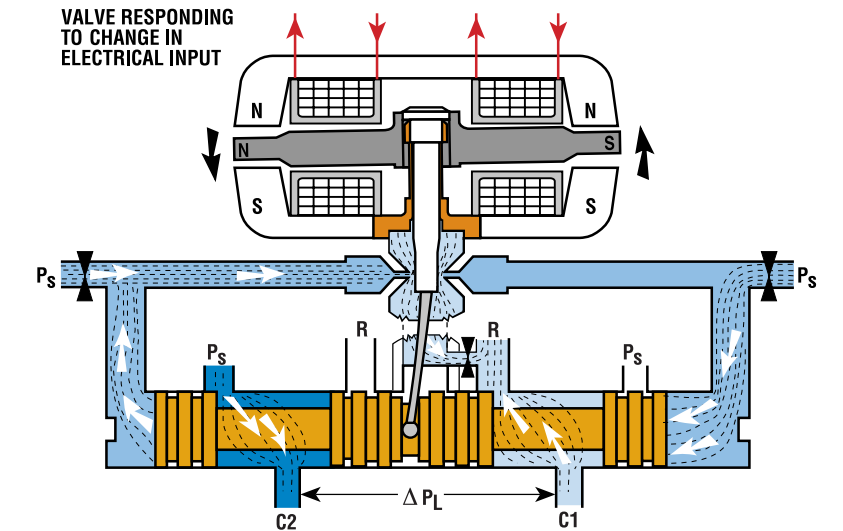
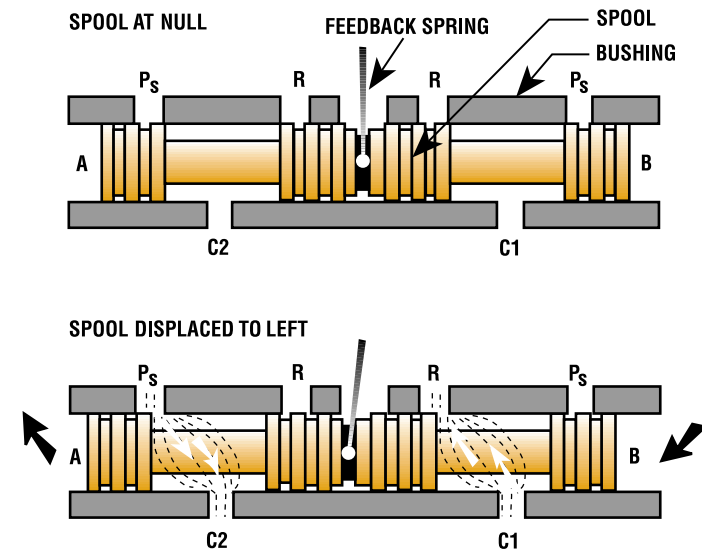

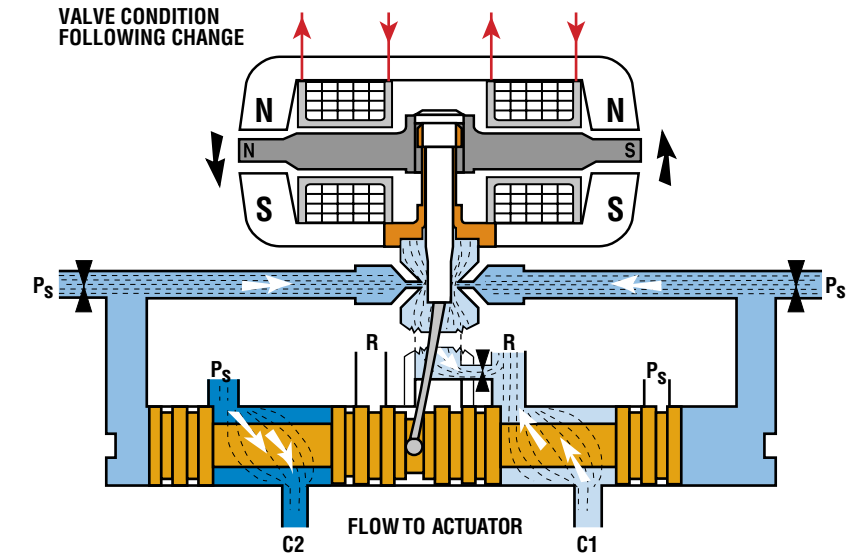

- Spool pushes ball end of feedback spring creating restoring torque on armature/flapper
- As feedback torque becomes equal to torque from magnetic forces, armature/flapper moves back to centered position
- Spool stops at a position where feedback spring torque equals torque due to input current
- Therefore spool position is proportional to input current
- With constant pressures, flow to load is proportional to spool position

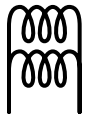

ELECTRICAL CHARACTERISTICS

Standard Coil Configurations

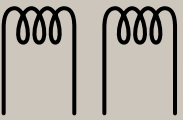
CODE FOR PART NUMBER OF STANDARD VALVE		P	S	I
INTERNAL COIL CONFIGURATION		PARALLEL COILS 	SERIES COILS 	INDIVIDUAL COILS 
PINS (IF CONNECTOR)		B A	B A	B A D C
COLORS (IF CABLE)		grn red	grn red	grn red yel blu
EXTERNAL CONNECTIONS TO GIVE FLOW OUT C2	SERIES COILS	Not possible	B+ A-	B+ Tie A, D C-
	PARALLEL COILS	B+ A-	Not possible	Tie B, D+ Tie A, C-
	DIFFERENTIAL COILS	Not possible	Not possible	Tie A, D for A, D+ when current A to B < D to C for A, D- when current B to A > C to D
	SINGLE COIL	Not possible	Not possible	B+ A- or D+ C-

Electrical Connector

- Standard configurations (see table below)
 - Bendix pygmy connector
 - 18 inch long cable
- Special Type 30 connectors
 - connector type and location per customer specification
 - flush manifold plug-in connector available

COIL CONFIGURATION AVAILABLE	CONNECTOR TYPE	CODE FOR PART NUMBER
P, S, D, I	*PC-02E-8-4P 4 pin screw	4 PC
P, S, D	*PC-02E-8-3P 3 pin screw	3 PC
P, S, D, I	*PT-02E-8-4P 4 pin bayonet	4 PT
P, S, D	*PT-02E-8-3P 3 pin bayonet	3 PT
I	4 wire cable, 18" long	**4 CA
D	3 wire cable, 18" long	3 CA
P, S	2 wire cable, 18" long	2 CA

* Bendix part number
** Only choice for Series 30

Dither

- Servo valve performance normally measured without dither
 - dither current may be applied to Type 30 Servo Valves
 - usually will decrease servo valve and actuator threshold
 - will increase spool null leakage
- Dither characteristics
 - frequency selected to suit system
 - peak-to-peak dither amplitude may be as high as $\pm 20\%$ servo valve rated current without degradation of valve life

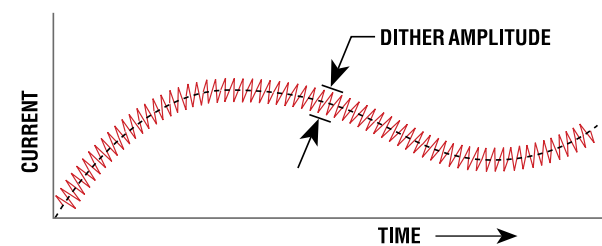

Rated Current

- Choice of coil resistance and coil connections determine valve rated current (see table below)
- Other coil resistance and rated current combinations can be supplied for special valves
 - lower rated current can be specified for standard coils, but with corresponding degradation of valve performance
- Triple rated current can be supplied indefinitely with no damage to servo valve

Coil Impedance

- Composed of
 - dc coil resistance
 - ac coil resistance
 - coil apparent inductance
- DC coil resistance
 - nominally equal for both coils, but may vary $\pm 10\%$ as coils are wound for desired number of turns
 - will vary with temperature (approximately 0.002 ohms/ohm °F)
- AC coil resistance
 - represents work done in moving armature
 - becomes significant above 200 Hz
- Coil apparent inductance
 - includes coil self inductance plus mutual inductance of other coil
 - mutual coupling of coils is approximately 50%
 - will vary considerably with motion of armature (due to back emf)
 - affected by valve supply pressure, signal amplitude, and signal frequency
 - may become capacitive at higher frequencies
 - usually specified at 50 Hz with normal operating conditions

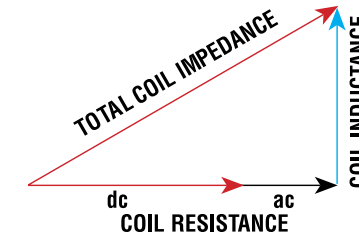

Servoamplifier

- Provides dc current into torque motor coils
 - regardless of coil inductance and resistance
 - requires current feedback amplifier
 - large shunt capacitance at output of amplifier may produce undesirable resonance with servo valve coil impedance
- Current feedback amplifier
 - eliminates apparent servo valve gain change due to changes in coil impedance
 - minimizes phase lag due to coil inductance
- Standard servo valve drive amplifiers available from Moog
 - table top units
 - low cost industrial units
 - aerospace units on special order

Code for Part Number of Standard Valve	P Parallel Coils			S Series Coils			I Individual Coils		
	R Ohms	L Henrys	i_R Ma	R Ohms	L Henrys	i_R Ma	R Ohms	L Henrys	i_R Ma
0040	20	0.10	50	80	0.36	25	40	0.12	50
0080	40	0.18	40	160	0.66	20	80	0.22	40
0130	65	0.30	30	260	1.1	15	130	0.37	30
0200	100	0.59	20	400	2.2	10	200	0.72	20
0500	250	1.1	15	1000	4.1	7.5	500	1.3	15
1000	500	2.6	10	2000	9.7	5	1000	3.2	10
1500	750	3.4	8	3000	12.5	4	1500	4.1	8

Note: Resistance values at 68°F (20°C) $\pm 10\%$ tolerance
Inductance values are typical for 50 Hz, servo valve pressurized. Inductance is not normally measured on individual servo valves.
*Inductance values per coil with differential operation (Class A push-pull).

HYDRAULIC CHARACTERISTICS

Supply Pressure

- 500 psi to 4000 psi for standard designs
 - valves are set up and tested at supply pressure specified
 - valves can be used at other supply pressures, but some null shift may occur
- Type 30 Servo Valves can function with supply pressures as low as 50 psid
 - servo valve performance, especially threshold and dynamic response, is degraded with low supply pressure

Proof and Burst Pressures

- Proof pressure capability
 - at supply and control ports = $1.5 P_s$
 - at return port = $1.0 P_s$
- Burst pressure capability
 - at supply and control ports = $2.5 P_s$
 - at return port = $1.5 P_s$ or 5000 psi maximum

Return Pressure

- May vary with minimal valve null shift
- Should never exceed supply pressure to avoid back flowing hydraulic amplifier

Rated Flow

- Each valve series covers a range of no-load rated flow to the maximum shown (for MIL-PRF-5606)

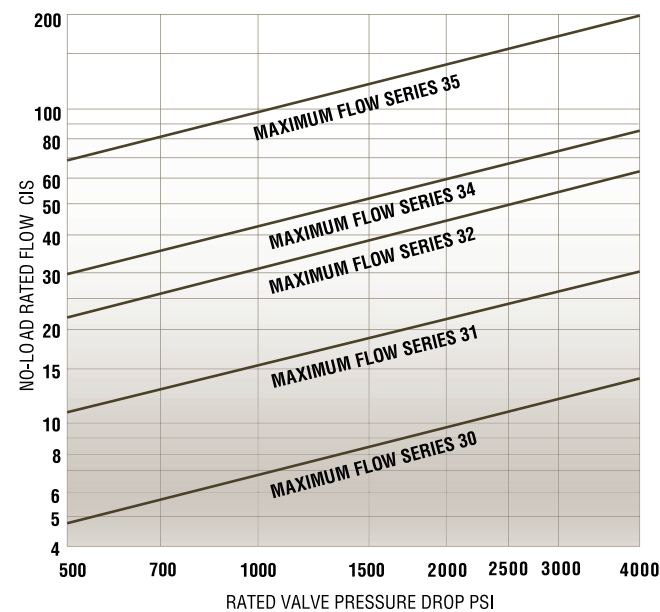

Standard Seals, Fluids, and Temperatures

O-RING ELASTOMER	COMPATIBLE FLUIDS	TEMP RANGE*	TEST FLUID	CODE FOR PART NO.
Buna N	MIL-PRF-83282 (synthetic hydrocarbon) Petroleum Base Fluids such as MIL-PRF-5606, MIL-PRF-6083, DTE, Regal, Brayco Silicone Fluids	-65°F to +275°F	MIL-PRF-83282 or MIL-PRF-5606	BUN
Fluorocarbon Rubber (Viton)	Petroleum Base Fluids such as Type A Transmission Fluid, JP-4, JP-5 Superrefined Mineral Oils Silicone Fluids Silicate Ester Fluids such as MLO-8200, OS-45, MZV Industrial Phosphate Ester Fluids such as Cellulube, Pydraul, Pyroguard Di-Ester Base Fluids such as MIL-PRF-7808, Houghton Safe Tri-Ester Base Fluids such as Trichloroethylene	-20°F to +400°F	MIL-PRF-83282 or MIL-PRF-5606	VIT
Ethylene Propylene Rubber	Aircraft Phosphate Ester Fluids such as Skydrol, Hyjet, Aerosafe Hydrazine** UDMH Water, steam, air	-65°F to +300°F	Hyjet IV A	EPR

*Operating temperature range may be further restricted by fluid.
** Standard Type 30 Servo Valves are suitable for short term use with this fluid. Special designs with all stainless steel wetted parts are recommended for long term use.

Flow-Load Characteristics

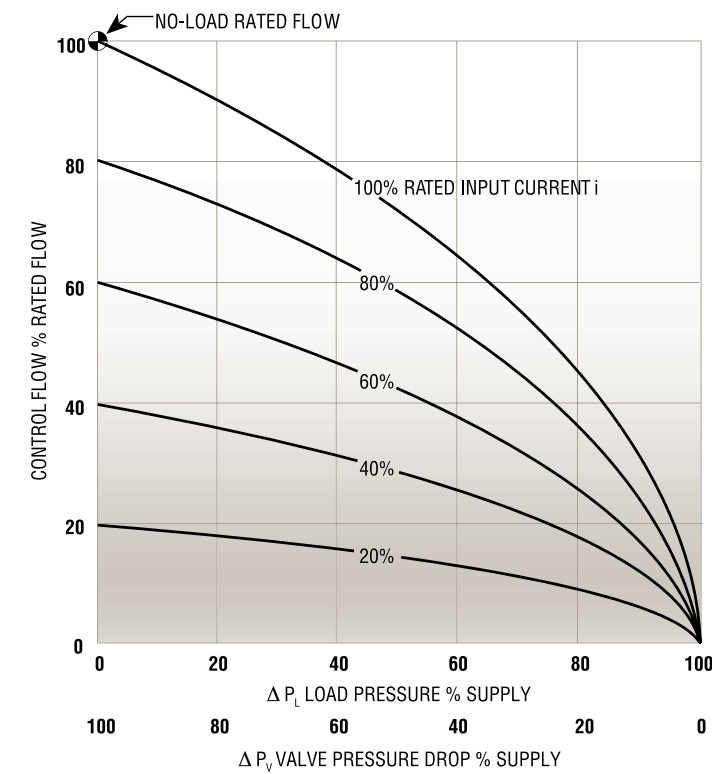

Nominal flow to load

$$Q_v = K_i \sum \Delta P_v$$

where Q_v = valve flow to load
 K = servo valve sizing factor
 i = input current
 ΔP_v = valve pressure drop

$$\Delta P_v = (P_s - R) - \Delta P_L$$

where P_s = supply pressure
 R = return pressure
 ΔP_L = load pressure drop

- Some flow saturation will occur with servo valves having maximum flow capacity
 - saturation causes droop at the high end of the flow curve

Spool Lap

- Standard servo valves have zero lap within limits of flow linearity shown on page 12
- Prescribed amounts of underlap or overlap can be specified on special order
 - underlap (or open center)
 - increases flow gain at null
 - reduces valve pressure gain at null
 - increases valve null leakage
 - overlap
 - reduces flow gain at null
 - reduces null leakage flow
 - reduces pressure gain (into a load)

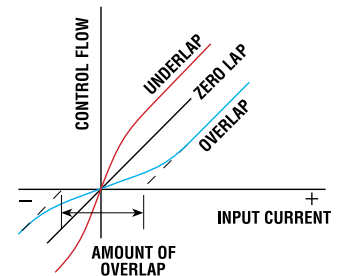

Internal Leakage

- Includes first stage hydraulic amplifier flow, spool null leakage flow, and bushing laminar leakage flow
 - spool null leakage flow is essentially zero when spool is off-null
 - servo valve internal leakage excluding spool null leakage is called tare flow
- Hydraulic amplifier flow largely determines servo valve frequency response
 - lower flow degrades response
- Spool null leakage flow is related to maximum valve flow (slot width) and null cut
 - special low leakage versions of Series 30 Servo Valve are available with <math><0.25\text{ cis}</math> at 3000 psi
 - table gives internal leakage of standard Type 30 Servo Valves (with MIL-H-5606 at 100°F)

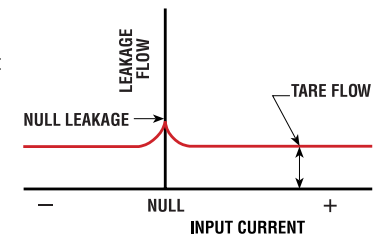

Maximum Leakage of Standard Type 30 Servo Valves

VALVE SERIES	TARE LEAKAGE FLOW CIS at 1000 psi	TARE LEAKAGE FLOW CIS at 3000 psi	SPOOL NULL LEAKAGE FLOW (% rated flow at rated pressure)
30	<0.20	<0.35	<4
31	<0.25	<0.45	<4
32	<0.28	<0.50	<3
34	<0.35	<0.60	<3
35	<0.45	<0.75	<3

*NOTE: Leakage will vary at different temperatures

STATIC PERFORMANCE

Control Flow

- Servo valve control flow to the load is nominally proportional to electrical input current
 - standard production acceptance test limits for no-load flow shown below
 - limits do not include servo valve hysteresis or null bias
 - limits at $\pm 100\%$ input for maximum flow designs may be $+10\%$, -20% due to non-linearities caused by flow saturation

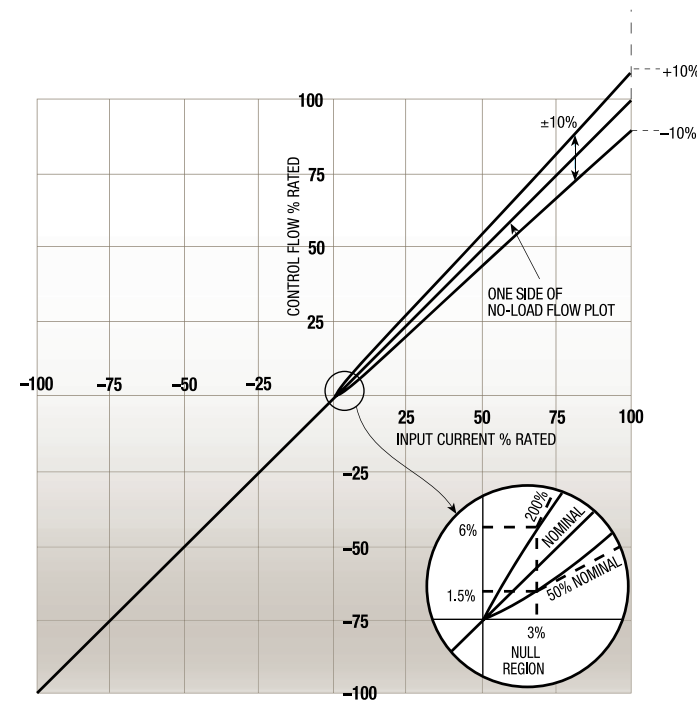

- Control flow non-linearity is greatest in null region
 - may be from 50% to 200% nominal gain within range of $\pm 3\%$ electrical input for standard null cut
 - can be held to closer limits on special order
- Maximum valve flow to 140% rated flow with oversignal
 - spool stops to limit maximum flow can be provided
- Control flow characteristic may change with fluid temperature
 - a $+100^\circ\text{F}$ temperature rise may cause control flow to increase as much as 3% due to fluid viscosity effects
 - at very high temperatures (over 400°F) a $+100^\circ\text{F}$ temperature rise may cause control flow to decrease by 3% due to magnetic effects

Pressure Gain

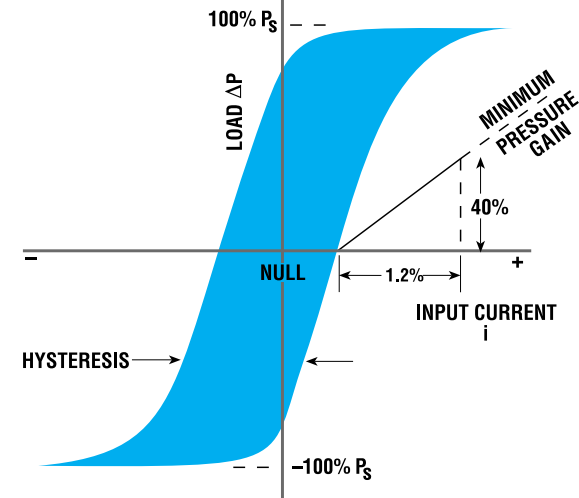

- Blocked load ΔP_L changes rapidly from $-P_s$ to $+P_s$ in null region
 - minimum pressure gain will be $0.4 P_s / 1.2\% i_r$ for standard servo valves
 - maximum pressure gain may be three times higher
 - pressure gain will decrease with spool null edge wear
- Special pressure gain requirements may interact with desired flow gain at null, spool null leakage, and nominal control port pressures at null

Hysteresis

- Maximum hysteresis for standard Type 30 Servo Valves with normal operation conditions is $< 3\%$
 - hysteresis may increase to 4% at -30°F

Threshold

- Maximum threshold for standard Type 30 Servo Valves with normal operating conditions is $< 1/2\%$ (without dither and with supply pressure greater than 1000 psi)
 - with P_s below 1000 psi threshold limit is $< 1\%$
 - threshold limit should be doubled at -30°F
 - with dither, threshold approaches 0%

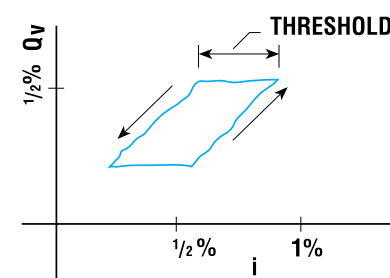

Null Bias

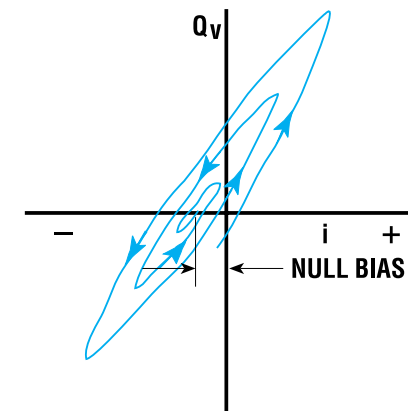

- Electrical input current to obtain valve null includes both temporary null shifts and permanent changes in null bias
- Null bias is measured under standard valve operating conditions (pressures, temperatures, environments)
- Null bias measurements exclude valve hysteresis
- Initial servo valve null bias on standard valves (as shipped) is less than 2% rated input
- Long-term null bias after exposure to environments and use can be expected to be $< 5\%$

Null Shift

- Change in null bias with environment and operating conditions will vary from unit to unit, but is generally:

	NULL SHIFT
TEMPERATURE	
50°F to 150°F	$< 2\%$
0°F to 200°F	$< 4\%$
ACCELERATION	
TO 40 G SPOOL AXIS	$< 0.3\%/G$
TO 40 G TRANSVERSE AXIS	$< 0.1\%/G$
SUPPLY PRESSURE	
60% TO 110%	$< 4\%$
QUIESCENT CURRENT	
50% TO 200% RATED CURRENT	$< 6\%$
BACK PRESSURE	
2% TO 20% OF SUPPLY	$< 4\%$

- Special mass balanced torque motor design available for $< 0.06\%/g$ to 400 g
- Null shifts are not normally tested during production acceptance testing
- Tighter null shift specifications can be imposed by providing 100% valve testing under critical environment

Spool Driving Force

- Typical spool driving force for standard servo valves at 3000 psi supply pressure is

SERIES	TYPICAL MAX. SPOOL FORCE (POUNDS)
30	55
31	55
32	110
34	140
35	160

- Special servo valves with lower hydraulic amplifier flow will have higher spool driving force gradients (but lower dynamic response)
- With system pressure less than 500 psi, spool driving forces are reduced and require clean system fluid for acceptable performance

Summary

STATIC PERFORMANCE (AT 100°F)

Rated flow tolerance*	$\pm 10\%$
Linearity	$< \pm 7\%$
Symmetry	$< \pm 5\%$
Null region	$< \pm 3\%$
Null bias	
Initial	$< \pm 2\%$
Long-term	$< \pm 5\%$
Hysteresis	$< 3\%$
Threshold	
Supply pressures 1000 psi and above	$< 0.5\%$
Supply pressures below 1000 psi	$< 1.0\%$
Pressure gain	
40% supply pressure at	$< 1.2\%$
Coil resistance tolerance	$\pm 10\%$
Supply proof pressure	$1.5 P_s$ or 6000 psi max
Supply burst pressure (not tested)	$2.5 P_s$ or 10,000 psi max
Return proof pressure	P_s or 4000 psi max
Return burst pressure (not tested)	$1.5 P_s$ or 5000 psi max
External leakage	None

*Max flow Series 30 $+10\%$ -15%

DYNAMIC PERFORMANCE

Frequency Response

- Will depend upon signal amplitude, supply pressure, and internal design configuration
- Plot below shows typical responses for standard Type 30 Servo Valves

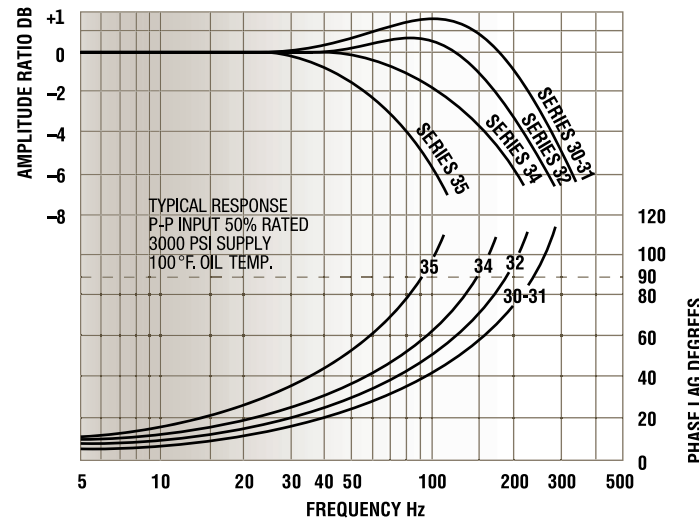

*NOTE: Peaking can be held to a tighter tolerance

- For system design these characteristics can be approximated by

VALVE SERIES	Equivalent First Order Time Constant sec.	Equivalent Second Order Natural Frequency Hz	Damping Ratio
30	0.0015	200	0.5
31	0.0015	200	0.5
32	0.0020	160	0.55
34	0.0029	110	0.6
35	0.0035	90	0.9

- Frequency response of specially designed valves can be improved by
 - increased hydraulic amplifier flow
 - shorter spool stroke (larger slot width)
 - use of stub shafts on spool ends
 - higher rated current (stiffer feedback spring)

Step Response

- Time response to step input current depends on valve design parameters
- Approximate transient response of standard Type 30 Servo valves operating at 3000 psi is

VALVE SERIES	Approximate Response Time to 90% Output sec.
30	0.0025
31	0.0025
32	0.0045
34	0.0070
35	0.0120

Internal Dynamics of Type 30 Servo Valves

See *Technical Bulletin 103* for a discussion of servo valve dynamic characteristics and response measuring techniques.

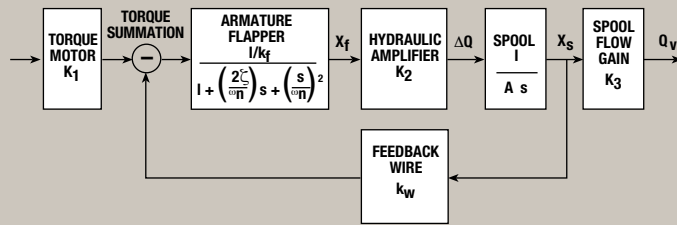

Typical Parameters for Series 31*

- i = torque motor current ± 10 ma
- x_s = spool displacement ± 0.015 in max
- Q_v = servo valve control flow ± 4 gpm
- K_1 = torque motor gain 0.025 in-lbs/ma
- K_2 = hydraulic amplifier flow gain $150 \frac{\text{in}^3/\text{sec}}{\text{in}}$
- K_3 = flow gain of spool/bushing $1030 \frac{\text{in}^3/\text{sec}}{\text{in}}$
- A = spool end area 0.026 in^2
- k_f = net stiffness on armature/flapper 115 in-lbs/in
- k_w = feedback wire stiffness 16.7 in-lbs/in
- b_f = net damping on armature/flapper $0.016 \frac{\text{in-lbs}}{\text{in}/\text{sec}}$
- I_f = rotational mass of armature/flapper $4.4 \times 10^{-6} \frac{\text{in-lbs}}{\text{in}/\text{sec}^2}$
- $\omega_n = \sum \frac{k_f}{I_f}$ natural frequency of first stage 814 Hz
- $\zeta = \frac{1}{2} \frac{b_f}{k_f} \omega_n$ damping ratio of first stage 0.4
- $K_v = \frac{K_2 k_w}{k_f A}$ servo valve loop gain 840 sec^{-1}

*Consult Moog Sales for parameters of other series valves.
*Contact Moog Engineering for specific requirements.

STANDARD SERIES 30 NOZZLE-FLAPPER SERVO VALVES



Installation Details 30S020

NOTE: CABLE SHOWN OVER RETURN PORT (CODE R) DIRECTION CAN BE OVER PRESSURE PORT (CODE P)

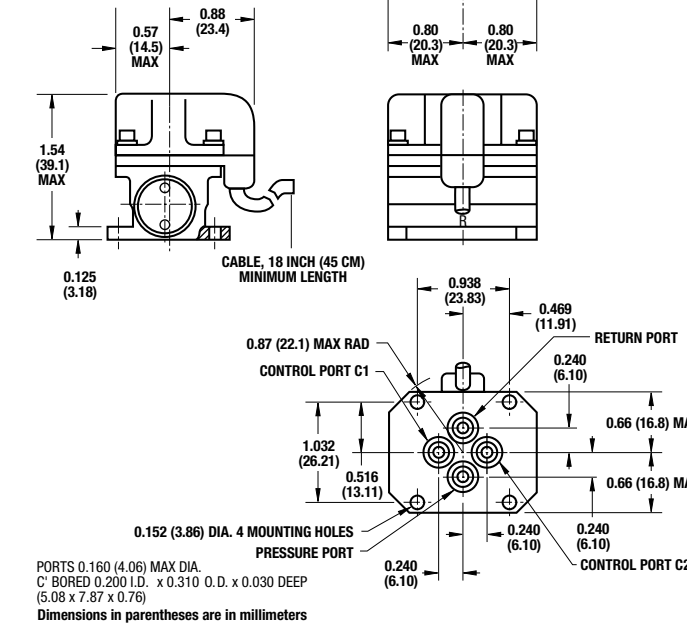

Typical frequency response for Standard Series 30 Servo Valves shown below

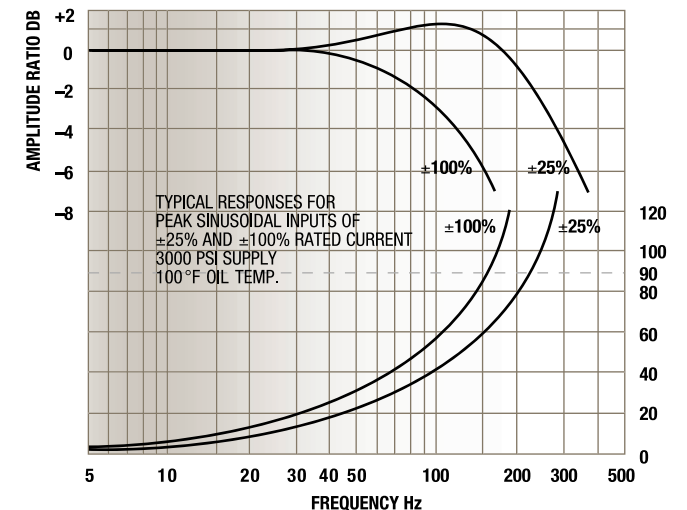

Standard design valves may be ordered by completing part number (see page 20)

- Specify rated control flow in cis within limits of table
 - use two digits and decimal point as indicated
 - specified flow will be provided for test fluid used (see page 10)
 - lower rated flows available on special order
- Specify supply pressure from 500 to 4000 psi to nearest 50 psi
 - lower and higher pressures available on special order

SUPPLY PRESSURE (no load valve pressure drop) PSI	Range of No-Load Rated Flow with MIL-PRF-5606			
	MINIMUM VALUE		MAXIMUM VALUE	
	CIS	GPM	CIS	GPM
500	.51	.13	4.9	1.3
1000	.69	.18	6.9	1.8
1500	.84	.22	8.5	2.2
2000	.96	.25	9.8	2.5
2500	1.1	.29	11.	2.9
3000	1.2	.31	12.	3.1
3500	1.3	.34	13.	3.4
4000	1.4	.36	14.	3.6

- Specify coil resistance per Table page 9
- Specify 4CA for 4 lead cable with individual coil connection (see page 8)
- Cable location over R or P only choice for Series 30
- Specify O-ring seal material per Table page 10

Performance of Standard Series 30 Servo Valves

(Tested on non-magnetic manifold)

Static..... see table page 13
Dynamic response limits at $\pm 25\%$ input per table

	Nominal Supply Pressure (psi)			
	500	1000	2000	3000
Maximum amplitude ratio	< 2db	< 2db	< 2db	< 2db
Frequency of 90° phase point	> 120Hz	> 150 Hz	> 170 Hz	> 200 Hz

Stock Series 30 Servo Valve

Part number 30 12. 3000 I 1000 4 CA R BUN normally carried in stock

Supply pressure.....3000 psi
Rated flow.....12 cis (3.1 gpm) no-load
6.9 cis (1.8 gpm) at 1000 psi valve drop

O-rings.....Buna N
Test fluid.....MIL-PRF-5606
Rated current.....10 ma parallel
Coil resistance.....1000 ohms/coil
Coil connection.....individual coils
Connector.....4 wire cable
Cable location.....over return port

STANDARD SERIES 31 NOZZLE-FLAPPER SERVO VALVES



Installation Details 31S020

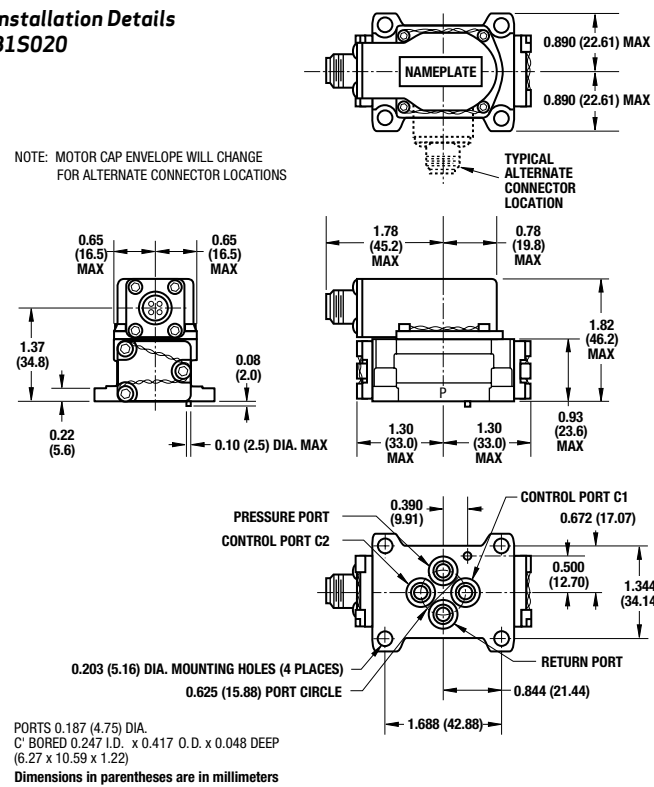

Typical frequency response for Standard Series 31 Servo Valves shown below

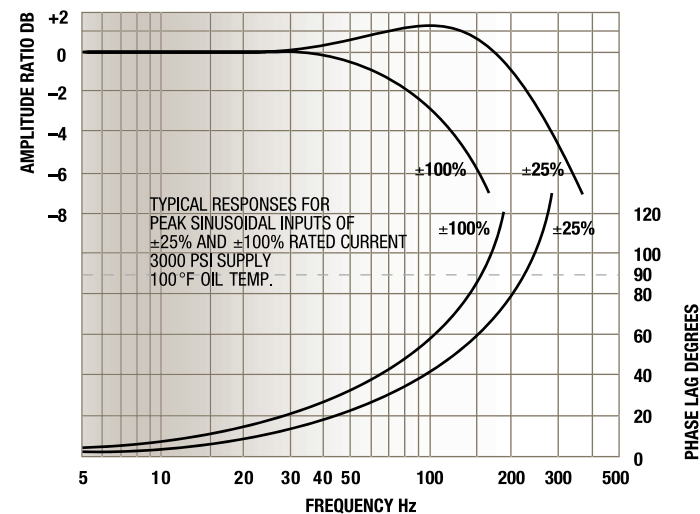

Standard design valves may be ordered by completing part number (see page 20)

- Specify rated control flow in cis within limits of table
 - use two digits and decimal point as indicated
 - specified flow will be provided for test fluid used (see page 10)
 - lower rated flows available on special order
- Specify supply pressure from 500 to 4000 psi to nearest 50 psi
 - lower and higher pressures available on special order

SUPPLY PRESSURE (no load valve pressure drop) PSI	Range of No-Load Rated Flow with MIL-PRF-5606			
	MINIMUM VALUE		MAXIMUM VALUE	
	CIS	GPM	CIS	GPM
500	2.7	0.7	11.	2.8
1000	3.8	1.0	15.	4.0
1500	4.7	1.2	19.	4.9
2000	5.4	1.4	22.	5.6
2500	6.1	1.6	24.	6.3
3000	6.7	1.7	26.	6.8
3500	7.2	1.9	28.	7.3
4000	8.3	2.2	30.	7.8

- Specify coil connection and coil resistance per Table page 9
- Specify connector or cable per code page 8
- Specify location of connector or cable
- Specify O-ring seal material per Table page 10

Performance of Standard Series 31 Servo Valves

(Tested on non-magnetic manifold)

Static..... see table page 13
Dynamicresponse limits at ±25% input per table

	Nominal Supply Pressure (psi)			
	500	1000	2000	3000
Maximum amplitude ratio	< 2db	< 2db	< 2db	< 2db
Frequency of 90° phase point	> 120Hz	> 150 Hz	> 170 Hz	> 200 Hz

Stock Series 31 Servo Valve

Part number 31 26. 3000 I 1000 4 PC 2 BUN
normally carried in stock

Supply pressure.....3000 psi

Rated flow.....26 cis (6.8 gpm) no-load
15 cis (4 gpm) at 1000 psi valve drop

O-rings.....Buna N

Test fluid.....MIL-PRF-5606

Rated current.....10 ma parallel

Coil resistance.....1000 ohms/coil

Coil connection.....individual coils

Connector.....Bendix PC-02E-8-4P

Connector location.....over control port 2

STANDARD SERIES 32 NOZZLE-FLAPPER SERVO VALVES



Installation Details 32S020

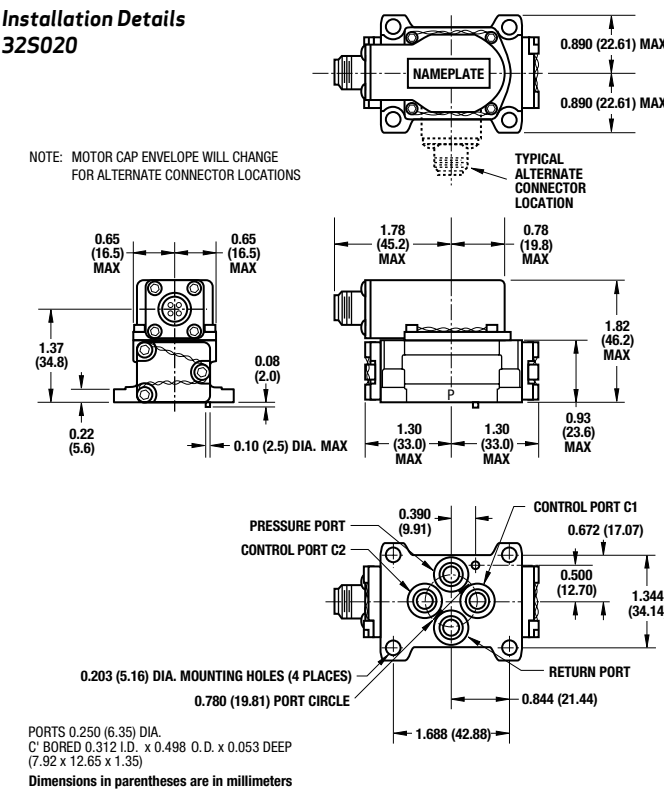

Typical frequency response for Standard Series 32 Servo Valves shown below

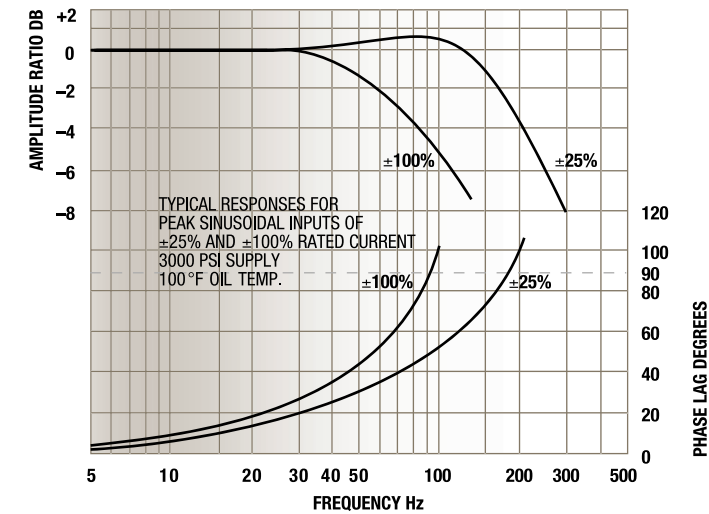

Standard design valves may be ordered by completing part number (see page 20)

- Specify rated control flow in cis within limits of table
 - use two digits and decimal point as indicated
 - specified flow will be provided for test fluid used (see page 10)
 - lower rated flows available on special order
- Specify supply pressure from 500 to 4000 psi to nearest 50 psi
 - lower and higher pressures available on special order

SUPPLY PRESSURE (no load valve pressure drop) PSI	Range of No-Load Rated Flow with MIL-PRF-5606			
	MINIMUM VALUE		MAXIMUM VALUE	
	CIS	GPM	CIS	GPM
500	11.	2.8	22.	5.7
1000	15.	4.0	31.	8.0
1500	19.	4.9	38.	9.8
2000	22.	5.6	44.	11.
2500	24.	6.3	48.	13.
3000	27.	6.9	54.	14.
3500	29.	7.5	58.	15.
4000	33.	8.6	62.	16.

- Specify coil connection and coil resistance per Table page 9
- Specify connector or cable per code page 8
- Specify location of connector or cable
- Specify O-ring seal material per Table page 10

Performance of Standard Series 32 Servo Valves

(Tested on non-magnetic manifold)

Static..... see table page 13
Dynamicresponse limits at ±25% input per table

	Nominal Supply Pressure (psi)			
	500	1000	2000	3000
Maximum amplitude ratio	< 2db	< 2db	< 2db	< 2db
Frequency of 90° phase point	> 120Hz	> 110 Hz	> 140 Hz	> 160 Hz

Stock Series 32 Servo Valve

Part number 32 54. 3000 I 1000 4 PC 2 BUN
normally carried in stock

Supply pressure.....3000 psi

Rated flow.....54 cis (14 gpm) no-load
31 cis (8 gpm) at 1000 psi valve drop

O-rings.....Buna N

Test fluid.....MIL-PRF-5606

Rated current.....10 ma parallel

Coil resistance.....1000 ohms/coil

Coil connection.....individual coils

Connector.....Bendix PC-02E-8-4P

Connector location.....over control port 2

STANDARD SERIES 34 NOZZLE-FLAPPER SERVO VALVES



Installation Details 34S020

NOTE: MOTOR CAP ENVELOPE WILL CHANGE FOR ALTERNATE CONNECTOR LOCATIONS

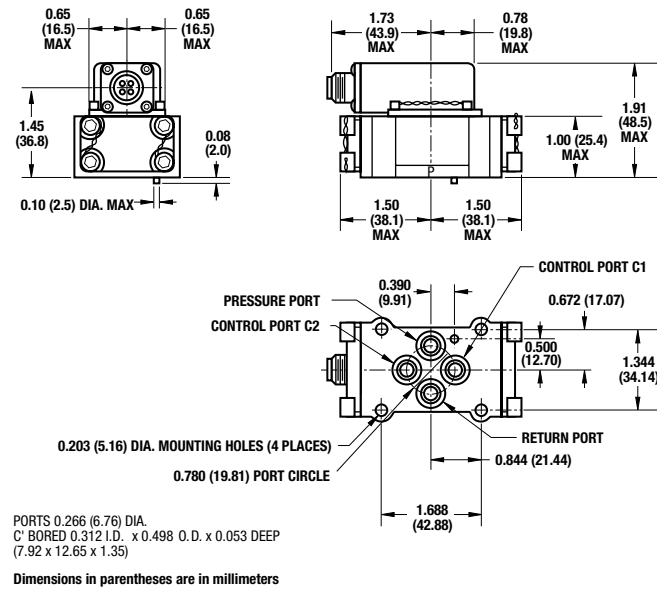

Typical frequency response for Standard Series 34 Servo Valves shown below

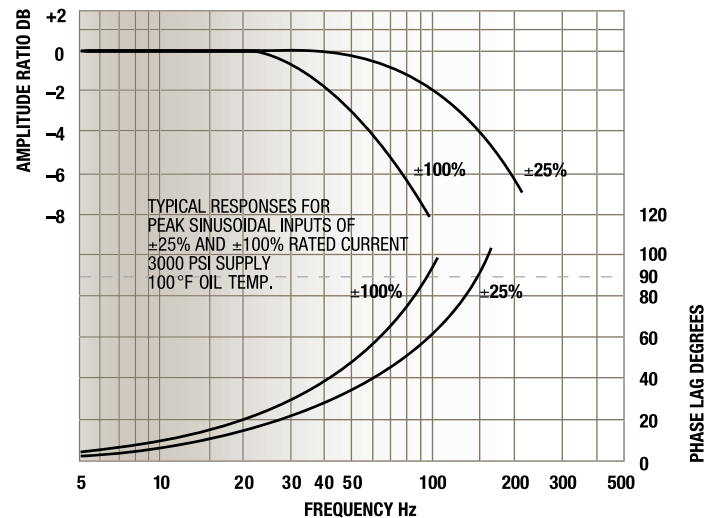

Standard design valves may be ordered by completing part number (see page 20)

- Specify rated control flow in cis within limits of table
 - use two digits and decimal point as indicated
 - specified flow will be provided for test fluid used (see page 10)
 - lower rated flows available on special order
- Specify supply pressure from 500 to 4000 psi to nearest 50 psi
 - lower and higher pressures available on special order

SUPPLY PRESSURE (no load valve pressure drop) PSI	Range of No-Load Rated Flow with MIL-PRF-5606			
	MINIMUM VALUE		MAXIMUM VALUE	
	CIS	GPM	CIS	GPM
500	22.	5.7	30.	7.8
1000	30.	7.8	42.	11.
1500	37.	9.6	54.	14.
2000	42.	11.	62.	16.
2500	45.	12.	66.	17.
3000	49.	13.	73.	19.
3500	52.	14.	77.	20.
4000	60.	16.	85.	22.

- Specify coil connection and coil resistance per Table page 9
- Specify connector or cable per code page 8
- Specify location of connector or cable
- Specify O-ring seal material per Table page 10

Performance of Standard Series 34 Servo Valves

(Tested on non-magnetic manifold)

Static..... see table page 13
Dynamicresponse limits at ±25% input per table

	Nominal Supply Pressure (psi)			
	500	1000	2000	3000
Maximum amplitude ratio	< 2db	< 2db	< 2db	< 2db
Frequency of 90° phase point	> 60Hz	> 80 Hz	> 95 Hz	> 110 Hz

Stock Series 34 Servo Valve

Part number 34 73. 3000 | 1000 4 PC 2 BUN
normally carried in stock
Supply pressure.....3000 psi
Rated flow.....73 cis (19 gpm) no-load
42 cis (11 gpm) at 1000 psi valve drop
O-rings.....Buna N
Test fluid.....MIL-PRF-5606
Rated current.....10 ma parallel
Coil resistance.....1000 ohms/coil
Coil connection.....individual coils
Connector.....Bendix PC-02E-8-4P
Connector location.....over control port 2

STANDARD SERIES 35 NOZZLE-FLAPPER SERVO VALVES



Installation Details 35S020

NOTE: MOTOR CAP ENVELOPE WILL CHANGE FOR ALTERNATE CONNECTOR LOCATIONS

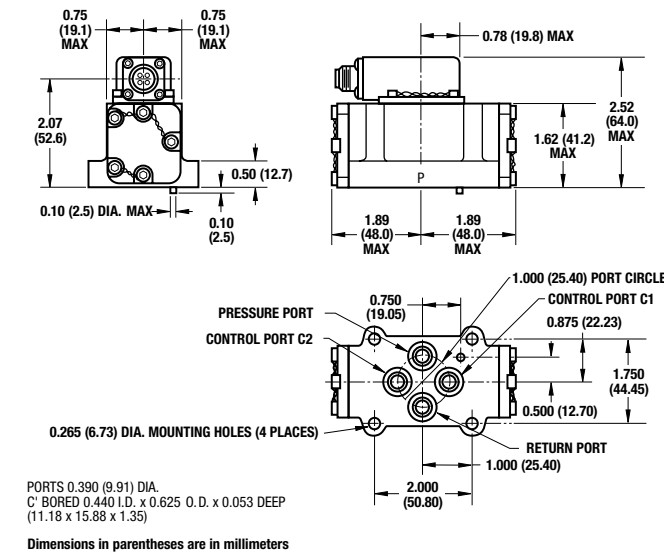

Typical frequency response for Standard Series 35 Servo Valves shown below

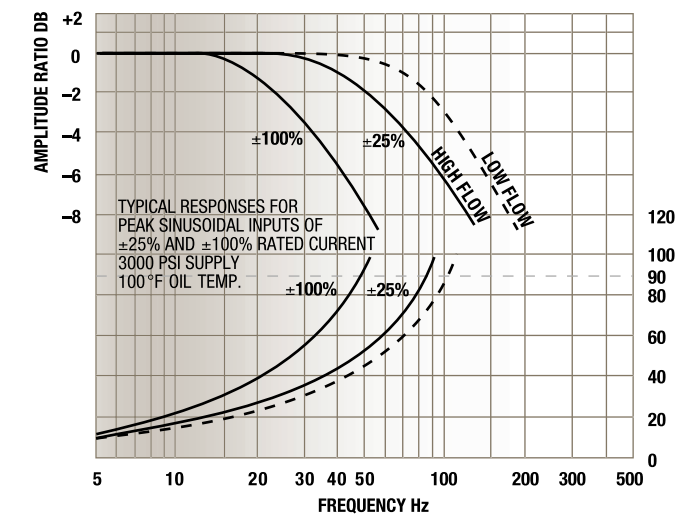

Standard design valves may be ordered by completing part number (see page 20)

- Specify rated control flow in cis within limits of table
 - use two digits and decimal point or three digits as indicated
 - specified flow will be provided for test fluid used (see page 10)
 - lower rated flows available on special order
- Specify supply pressure from 500 to 4000 psi to nearest 50 psi
 - lower and higher pressures available on special order

SUPPLY PRESSURE (no load valve pressure drop) PSI	Range of No-Load Rated Flow with MIL-PRF-5606			
	MINIMUM VALUE		MAXIMUM VALUE	
	CIS	GPM	CIS	GPM
500	34.	8.8	69.	18.
1000	46.	12.	100	26.
1500	56.	15.	120	31.
2000	61.	16.	139	36.
2500	68.	18.	155	40.
3000	73.	19.	170	44.
3500	77.	20.	183	48.
4000	84.	22.	196	51.

- Specify coil connection and coil resistance per Table page 9
- Specify connector or cable per code page 8
- Specify location of connector or cable
- Specify O-ring seal material per Table page 10

Performance of Standard Series 35 Servo Valves

(Tested on non-magnetic manifold)

Static..... see table page 13
Dynamicresponse limits at ±25% input per table

	Nominal Supply Pressure (psi)			
	500	1000	2000	3000
Maximum amplitude ratio	< 2db	< 2db	< 2db	< 2db
Frequency of 90° phase point	Low Flow > 50 Hz High Flow* > 40 Hz	> 70 Hz > 55 Hz	> 85 Hz > 65 Hz	> 100 Hz > 80 Hz

*Rated flow above equivalent 115 cis at 3000 psi.

Stock Series 35 Servo Valve

Part number 35 115 3000 | 1000 4 PC 2 BUN
normally carried in stock
Supply pressure.....3000 psi
Rated flow.....115 cis (30 gpm) no-load
66 cis (17 gpm) at 1000 psi valve drop
O-rings.....Buna N
Test fluid.....MIL-PRF-5606
Rated current.....10 ma parallel
Coil resistance.....1000 ohms/coil
Coil connection.....individual coils
Connector.....Bendix PC-02E-8-4P
Connector location.....over control port 2

INSTALLATION INFORMATION

Fluid Cleanliness

- Supply fluid must be well filtered for long, trouble-free operation
 - System contamination levels better than NAS 1638 Class 6 are recommended
 - Type 30 Servo Valves will operate on contaminated fluid, but will exhibit increased null leakage and threshold with valve life

System Filtration

- Supply fluid to Type 30 Servo Valves should be filtered with a 10µm nominal (or better), full flow, non-bypass type filter
 - servo valve internal filter (20µm nominal) protects hydraulic amplifier from gross contamination
- System should be flushed for clean-up prior to installing servo valves

Manifold Details

- Manifold flatness less than 0.001 TIR
- O-ring port sealing surface finish 32/
- Manifold material to suit application
 - standard servo valves tested on non-magnetic material manifolds; some change in servo valve gain may occur when mounted on magnetic material manifolds

LOCATIONS

Argentina	Germany	South Africa
Australia	India	South Korea
Austria	Ireland	Spain
Brazil	Italy	Sweden
Canada	Japan	Switzerland
Costa Rica	Luxembourg	Turkey
Czech Republic	The Netherlands	United Arab Emirates
Finland	Norway	United Kingdom
France	Philippines	United States
	Singapore	

ORDERING INFORMATION FOR STANDARD TYPE 30 SERVO VALVES

Shipping

- Standard valves shipped with shipping plate
 - valves are sealed in plastic bags and individually boxed
- Shipping carton for standard servo valves contains copy of valve flow plot and internal leakage plot

Special Order

- Contact Moog for customization options

PLEASE SPECIFY PART NUMBER AS FOLLOWS

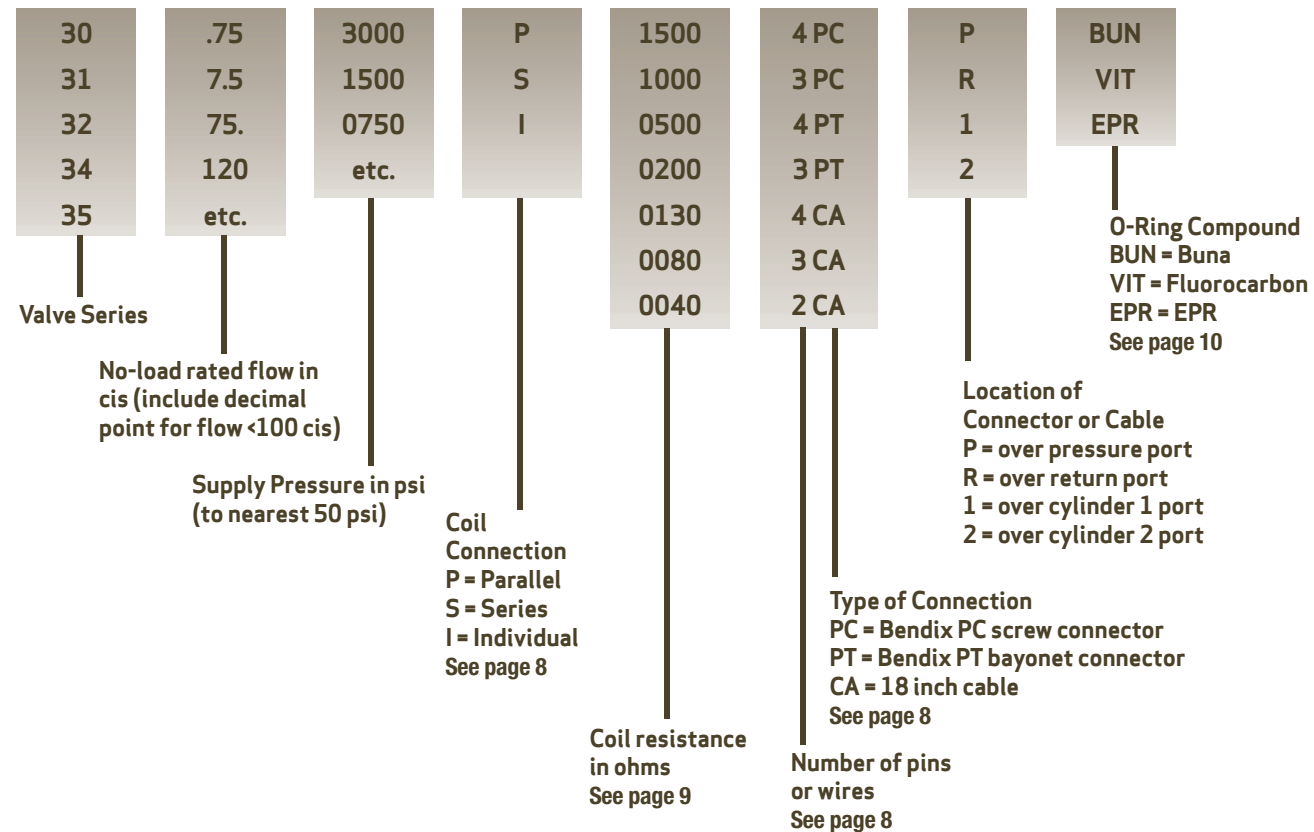

AMERICAS
+1 716.687.4373
defense@moog.com
moog.com/defense

EUROPE
+49 (0) 7031.6220
defenceurope@moog.com
moog.com/defence

AUSTRALIA
+61.3.9561.6044
info.australia@moog.com
moog.com.au

TEWKESBURY
sales@moog.com
moog.co.uk



Equipment described herein falls under the jurisdiction of the EAR and may require U.S. Government Authorization for export purposes. Diversion contrary to U.S. law is prohibited.
The appearance of U.S. Department of Defense (DoD) visual information does not imply or constitute DoD endorsement.
©2022 Moog, Inc. All rights reserved.
Product and company names listed are trademarks or trade names of their respective companies.