

ELECTROMECHANICAL ROTARY ACTUATORS

GUN/TURRET/RADAR DRIVES FOR LAND SYSTEMS



Moog's electromechanical rotary actuators are designed to meet or exceed the demanding requirements of new and existing land system gun, turret, and radar applications through world-class stabilization and pointing accuracy. These actuators are used for new and existing combat vehicle platform control applications, heavy payloads requiring high slew-to-cue capability, and as a power drive unit for larger mechanical actuated systems.

Features include a brushless DC motor which can be integrated in a 28VDC system up to a 600VDC system. The output pinion of the actuator can pair with a ring or sector gear or can couple directly to the load. The gear can be modified to mate with any customer defined ring/sector gear. The actuator also features a failsafe clutch, manual drive, and no-back.

Moog is a worldwide designer, manufacturer, and integrator of custom precision motion control and stabilization systems for the defense industry. Our electromechanical rotary and linear actuators are ideal for new systems, upgrades to older hydraulic systems, and for sustainment services.

KEY FEATURES

- Brushless DC motor (28VDC to 600VDC options)
- Integrated brushless resolver or absolute encoder for motor commutation
- Output pinion designed to interface with customer defined ring/sector gear
- Integrated failsafe 18VDC to 32VDC clutch
- Integrated manual drive with custom input ratios
- No-back (optional)
- Design, tested, and qualified to MIL-STD 810E and MIL-STD 461E
- MIL-Spec electrical connectors
- On board absolute encoder position sensor (optional)
- Oil filled for lubrication and heat management (optional)



Credit: U.S. Marine Corps/Cpl. Adam Henke



Credit: U.S. Army



Credit: U.S. Air Force/A1C Sean Worrell

PLATFORM AZIMUTH DRIVE

CA76728

PERFORMANCE

Features	Specifications
Peak torque	267.5 FTLB (403.4 Nm)
Rated torque	136 FTLB (184.4 Nm)
Rated speed	164.2 rpm
No load speed	217 rpm
Minimum static holding torque (brake engaged)	997.6 FTLB (1,353 Nm)
Supply voltage (nom.)	600VDC
Backlash	< 28 arc-min.
Weight	84 lbs (185 kg)



ARCHITECTURAL AND DIMENSIONAL DRAWING

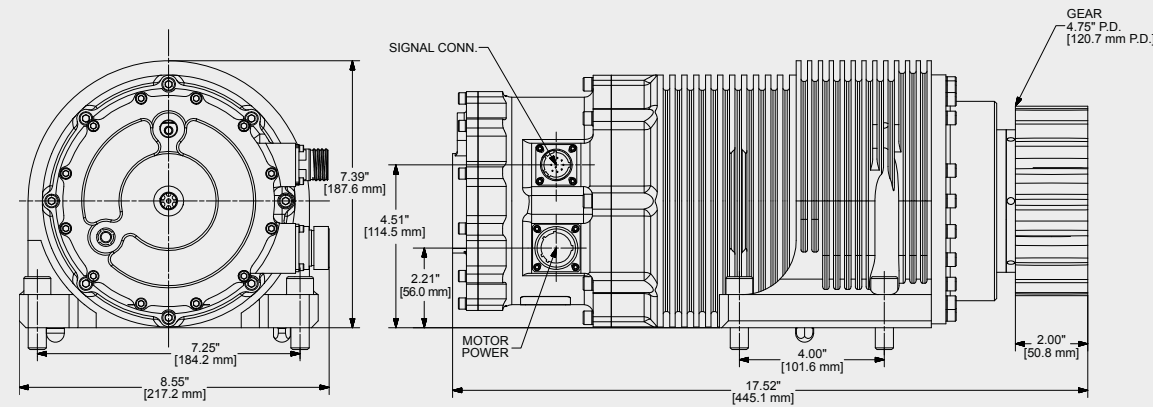

LAUNCHER AZIMUTH DRIVE

ICD CCB91028

PERFORMANCE

Features	Specifications
Peak torque	3,975 FTLB (5,389 Nm)
Rated torque	1,553 FTLB (2,106 Nm)
Rated speed	19 rpm
No load speed	75 rpm
Minimum static holding force (clutch engaged)	2,310 FTLB (3,132 Nm)
Supply voltage (nom.)	600VDC
Backlash	< 3 arc-min.
Weight	360 lbs (792 kg)



ARCHITECTURAL AND DIMENSIONAL DRAWING

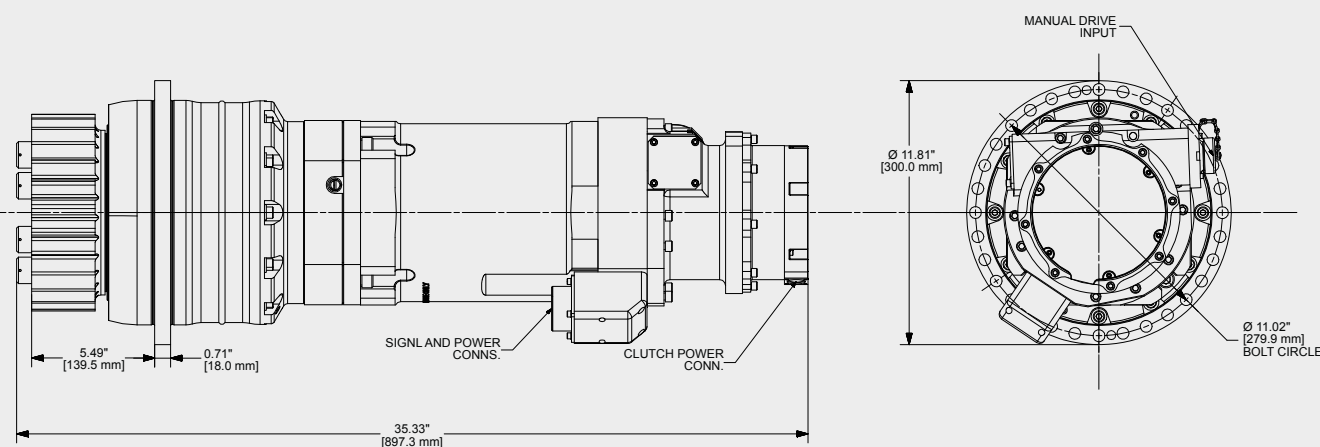

INFANTRY FIGHTING VEHICLE ELEVATION ACTUATOR

C7L265M

PERFORMANCE

Features	Specifications
Peak force	4,260 LBF (19.0 kN)
Rated force	1,450 LBF (6.45 kN)
Rated speed	4.3"/s (109 mm/s)
No load speed	5.4"/s (137 mm/s)
Clutch holding force	9,000 LBF (40.0 kN)
Supply voltage	18VDC - 32VDC, 270VDC, 650VDC; 3 x 380VAC, 50 - 60 Hz
Stiffness	300 kLBF/in (52.5 kN/mm)
Backlash	0.015" (0.381 mm)
Weight	76.7 lbs (34.7 kg)
Retracted length	22.9" (581 mm)
Extended length	33.3" (846 mm)



INFANTRY FIGHTING VEHICLE TRAVERSE ACTUATOR

PERFORMANCE

Features	Specifications
Peak torque	280 Nm (2,480 LBIN)
Rated torque	85 Nm (750 LBIN)
Rated speed	85 rpm
Clutch holding torque	400 Nm (3,570 LBIN)
Supply voltage	24VDC, 48VDC, 270VDC, or 650VDC
Stiffness	7.75 kNm/deg (68.6 kLBIN/deg)
Backlash	5.7 arc-min.
Weight	54 lbs (24.5 kg)



ARCHITECTURAL AND DIMENSIONAL DRAWING

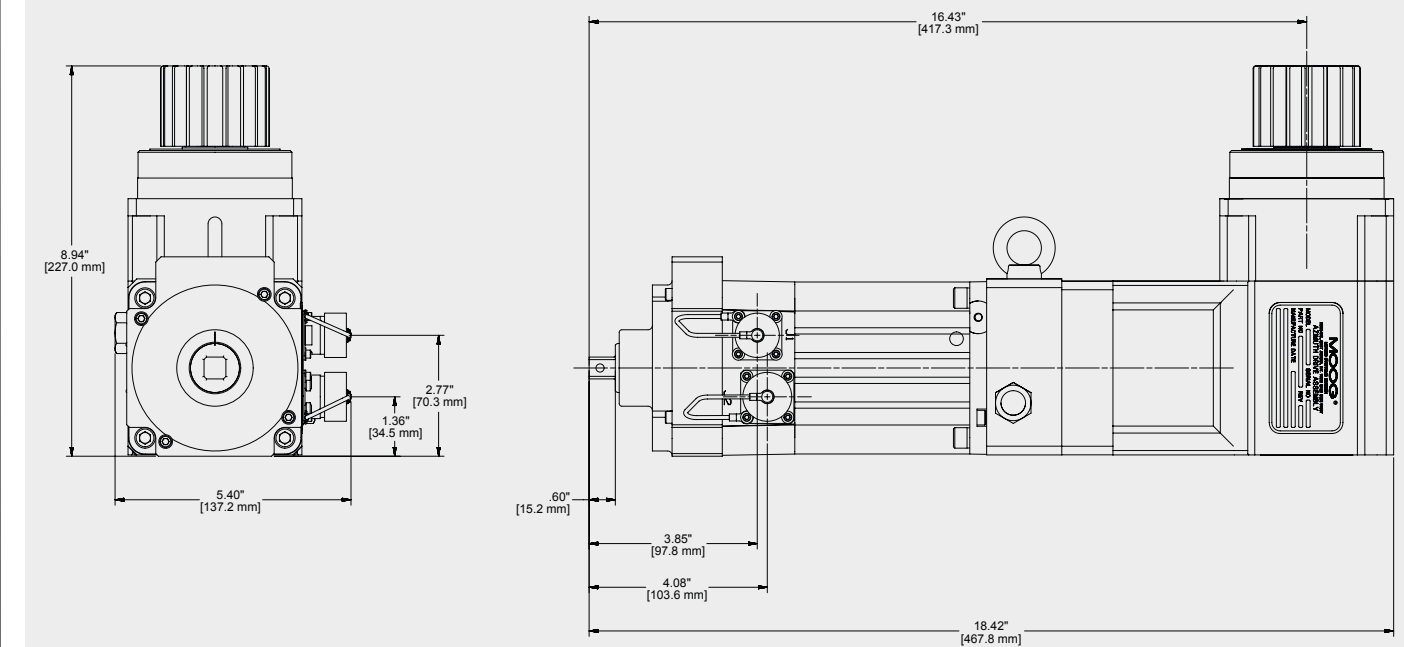

PLATFORM POWER DRIVE UNIT

ICD CB60333



PERFORMANCE

Features	Specifications
Peak torque	254 FTLB (344.4 Nm)
Rated torque	56.7 FTLB (76.9 Nm)
Rated speed	103 rpm
No load speed	143 rpm
Minimum static holding torque (brake engaged)	219 FTLB (297 Nm)
Supply voltage (nom.)	600VDC
Weight	30.9 lbs (67.9 kg)

ARCHITECTURAL AND DIMENSIONAL DRAWING

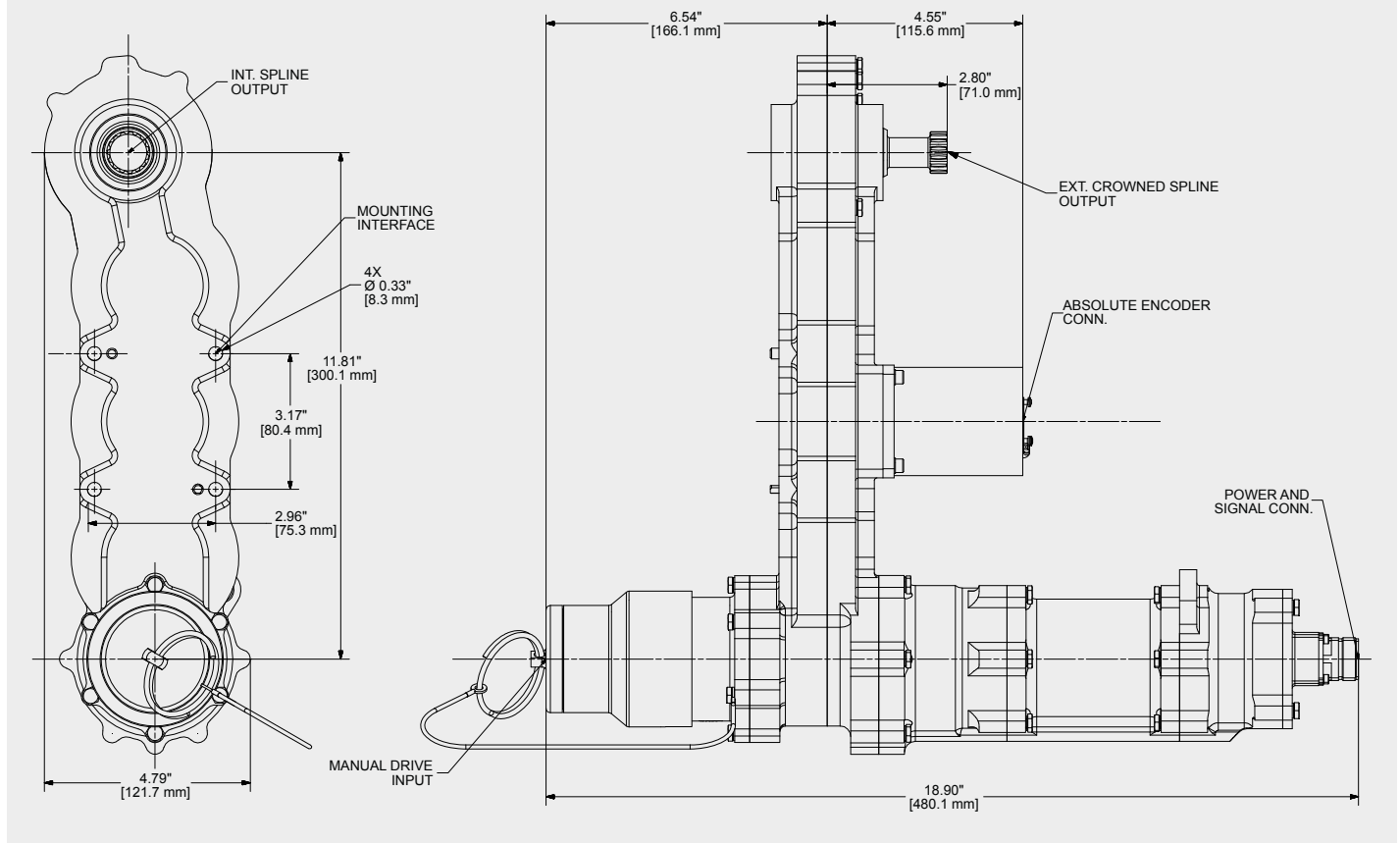

MOOG

AMERICAS
dcs@moog.com
www.moog.com/defense

AUSTRALIA
Info.australia@moog.com
www.moog.com.au

EUROPE
defenceurope@moog.com
www.moog.com/defence



Moog Space and Defense



Moog Inc.



@Moog_Inc



@Moog.Inc

The appearance of U.S. Department of Defense (DoD) visual information does not imply or constitute DoD endorsement.

Equipment described herein falls under the jurisdiction of the ITAR and requires US Government Authorization for export purposes. Diversion contrary to US law is prohibited.

©2024 Moog, Inc. All rights reserved.

Product and company names listed are trademarks or trade names of their respective companies.

Form 500-1405 0324