



## TYPE 33 BIAXIAL GIMBAL



The Type 33 Biaxial Gimbal is of a size appropriate for many antennas, and it has become by far our most popular Antenna Pointing Mechanism configuration. Available in either Elevation/Azimuth or X/Y, these units have proven their reliability and versatility many times over. Each actuator of the gimbal can incorporate cable management capability. The actuators are based on Moog's heritage Type 3 actuator design with significant on-orbit experience.

The gimbals can incorporate a wide range of options. Launch locks, caging mechanisms, cable management systems, position sensors and waveguide brackets/mounting features are some examples of the options available to the designer. Please contact Moog engineers for assistance when evaluating options for your application.

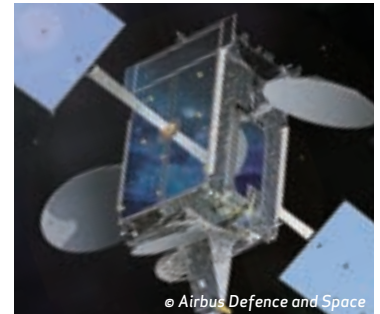

# TYPE 33 BIAXIAL GIMBAL

## PERFORMANCE SPECIFICATIONS

Characteristic	Units	Basis	Data
Output Step Angle*	Degrees	Standard	0.009375
Steps/Revolution*	–	Standard	38,400
Harmonic Drive Ratio*	–	Standard	160:1
Output Step Rate*	Step/Sec (Deg/Sec)	Maximum	400 (3.75)
Power*	Watts	Nominal	10
Inertial Capability*	Slug ft <sup>2</sup>	Typical	25
	kg-m <sup>2</sup>	Typical	34
Output Torque*	lb-in	Typical	150
	N-m	Typical	17
Holding Torque Powered*	lb-in	Typical	300
	N-m	Typical	34
Unpowered*	lb-in	Typical	80
	N-m	Typical	9.0
Torsional Stiffness in the AZ-EL Plane	lb-in/rad	Typical	150,000
	N-m/rad	Typical	16,950
Perpendicular to Plane	lb-in/rad	Typical	110,000
	N-m/rad	Typical	12,428
Output Flange Load Capability Axial	lb	Maximum	420
	N	Maximum	1,868
Transverse	lb	Maximum	420
	N	Maximum	1,868
Moment	lb-ft	Maximum	150
	N-m	Maximum	203
Total Assembly Weight	lb	Typical	9.6
	kg	Typical	4.4

\* Each Axis  
Please contact Moog application engineers to discuss optional actuator performance requirements

## DIMENSIONAL DRAWINGS

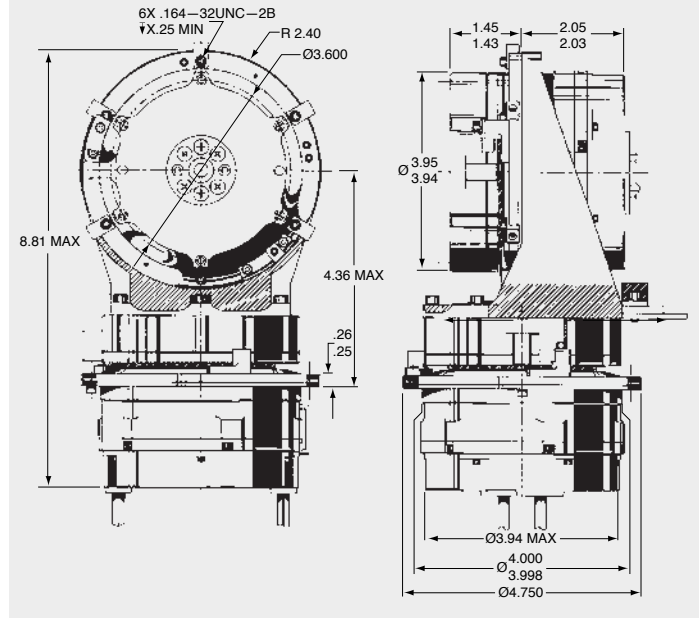

**MOOG**  
SPACE AND DEFENSE GROUP

21339 Nordhoff Street, Chatsworth, California 91311 USA  
+1.818.734.6700 Fax: +1.818.341.3884  
www.moog.com



MoogSpace and Defense



@MoogSDG



@MoogSDG



@MoogSDG



@MoogInc

Equipment described herein falls under the jurisdiction of the EAR and may require US Government Authorization for export purposes. Diversion contrary to US law is prohibited.

© 2021 Moog, Inc. All rights reserved.  
Product and company names listed are trademarks or trade names of their respective companies.

Form 500-1149 0421