

FILL AND DRAIN SERVICE VALVES

ELECTRIC AND CHEMICAL PROPULSION



These mechanically operated valves are opened/closed by rotating an actuation nut. The ground connection is a standard AN-style fitting that can be attached prior to operating the valve. The actuation nut, AN cap, and valve cover have tie wire provisions.

KEY ADVANTAGES

- Triple Redundant External Leakage Seals
 - Primary Seal - Metal to metal seat
 - Secondary Seal - AN cap and redundant shaft seal orings
 - Tertiary Seal - Cover with o-ring
- Stainless Steel or Titanium Construction with EPR or KALREZ® Seals
- Compatible with various gases and storable propellants
- Easily adapted for mounting interface and tubing size

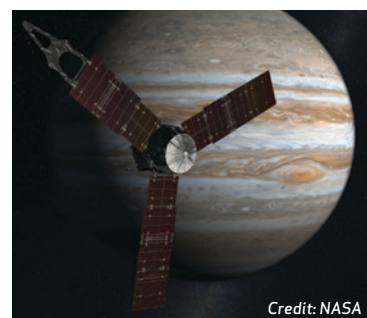
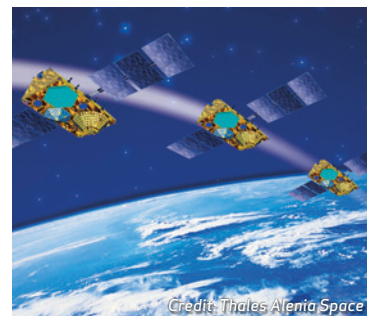
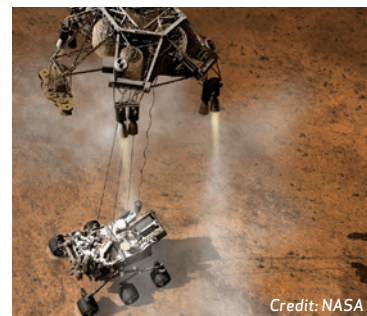

FILL AND DRAIN SERVICE VALVES

PRODUCT DIMENSIONS

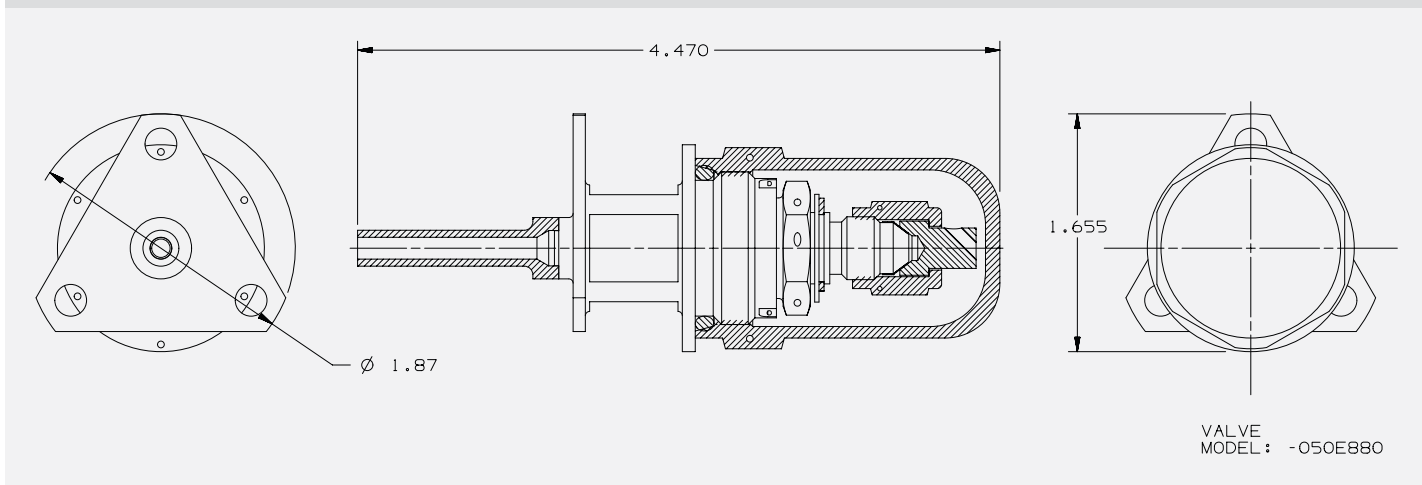

PERFORMANCE CHARACTERISTICS

Characteristic	Low Pressure Stainless Steel with Cover	Low Pressure Titanium with Cover	High Pressure Stainless Steel	High Pressure Titanium with Cover
Max Operating Pressure, MEOP	650 psig (43.8 bar)	650 psig (43.8 bar)	5,000 psig (343.7 bar)	5,000 psig (343.7 bar)
Proof Pressure	975 psig (66.2 bar)	975 psig (66.2 bar)	7,500 psig (516.1 bar)	7,500 psig (516.1 bar)
Burst Pressure	1,625 psig (111 bar)	1,625 psig (111 bar)	12,500 psig (860.8 bar)	12,500 psig (860.8 bar)
Flow and Pressure Drop	0.15 lb/s H ₂ O 20 psid; 3.4 scfm GHe at 650 psia and 10 psid		0.15 lb/s H ₂ O @ at 40 psid; 51 scfm GHe at 4000 psia and 20 psid	
Primary Seal Leakage, Internal/External	1E-6 scc/s	1E-6 scc/s	1E-6 scc/s	1E-6 scc/s
Secondary Seal Leakage, External	1E-5 scc/s	1E-5 scc/s	1E-5 scc/s	1E-5 scc/s
Tertiary Seal Leakage, External	1E-5 scc/s	1E-5 scc/s	N/A scc/s	1E-5 scc/s
Cycle Life	150 cycles	150 cycles	150 cycles	150 cycles
Weight	0.46 lbm (209 gram)	0.46 lbm (209 gram)	0.34 lbm (155 gram)	0.46 lbm (209 gram)
Operating Temperature Range	19 to 140°F (-7.2 to 60°C)	19 to 140°F (-7.2 to 60°C)	19 to 140°F (-7.2 to 60°C)	19 to 140°F (-7.2 to 60°C)
Representative Model Numbers	-050E880	-050E835	-050E873	-050E889

A higher pressure variant has also been developed with a MEOP of 8,000 psig

MOOG
SPACE AND DEFENSE GROUP

Bill Vogt
bvogt@moog.com
+1.716.687.4109



Moog Space and Defense



@MoogSDG



@MoogSDG



@MoogSDG



@MoogInc

Equipment described herein falls under the jurisdiction of the EAR and may require US Government Authorization for export purposes. Diversion contrary to US law is prohibited.

© 2022 Moog, Inc. All rights reserved.
Product and company names listed are trademarks or trade names of their respective companies.

Form 500-935 0922