

MICRO3 ROTARY INCREMENTAL ACTUATOR

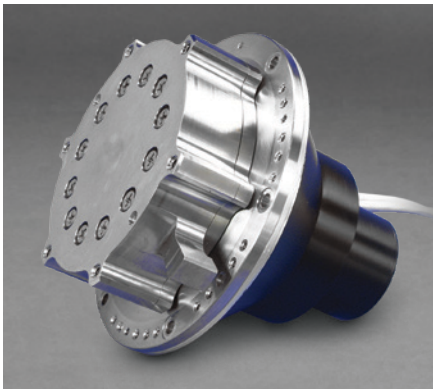

The Moog Micro3 rotary incremental actuator is a compact, closely integrated design made up of two key elements: a rotary actuator and a standard Type 3 speed reducer and output flange. The motor is a small angle permanent magnet stepper with relatively high holding torque. The multi-stage speed reducer offers a large reduction ratio, low weight, low power consumption,

zero backlash and high torsional stiffness. Co-axial nesting of the motor and transmission drive elements gives the unit low profile geometry. The actuator can be made available in two and three phase motors with optional features such as potentiometer/resolver output position feedback. The actuator has the identical mounting features of the Moog standard Type3 line of Rotary Actuators.

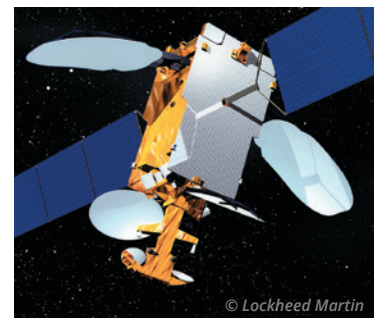
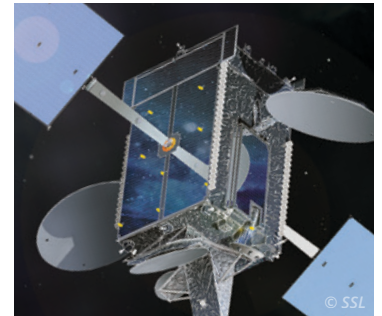

MICRO3 ROTARY INCREMENTAL ACTUATOR

SPECIFICATIONS

	Units	Micro3 Configuration		
		1	2	3
Output Step Size	Degree	0.00094	0.0015	0.003
Steps Per Revolution	-	384000	240000	120000
Gear Reduction Ratio	-	16000	5000	2500
Motor Step Angle	Degree	15	7.5	7.5
Maximum Output Step Rate	pps	640	600	600
Maximum Output Speed	Deg/Sec	0.6	0.9	1.8
Output Running Torque	Nm	90	28	14
Unpowered Holding Torque	Nm	120	38	20
Torsional Stiffness	Nm/Rad	17000		
Power Consumption	Watts	3 watts at ambient		
Load Capability				
Axial	N	9800		
Transverse	N	6670		
Moment	Nm	325		
Total Assembly Weight	Grams	1600		
Environment				
Temperature Range	C	-45 to +85		
Vibration Level	Grams	26		

DIMENSIONS

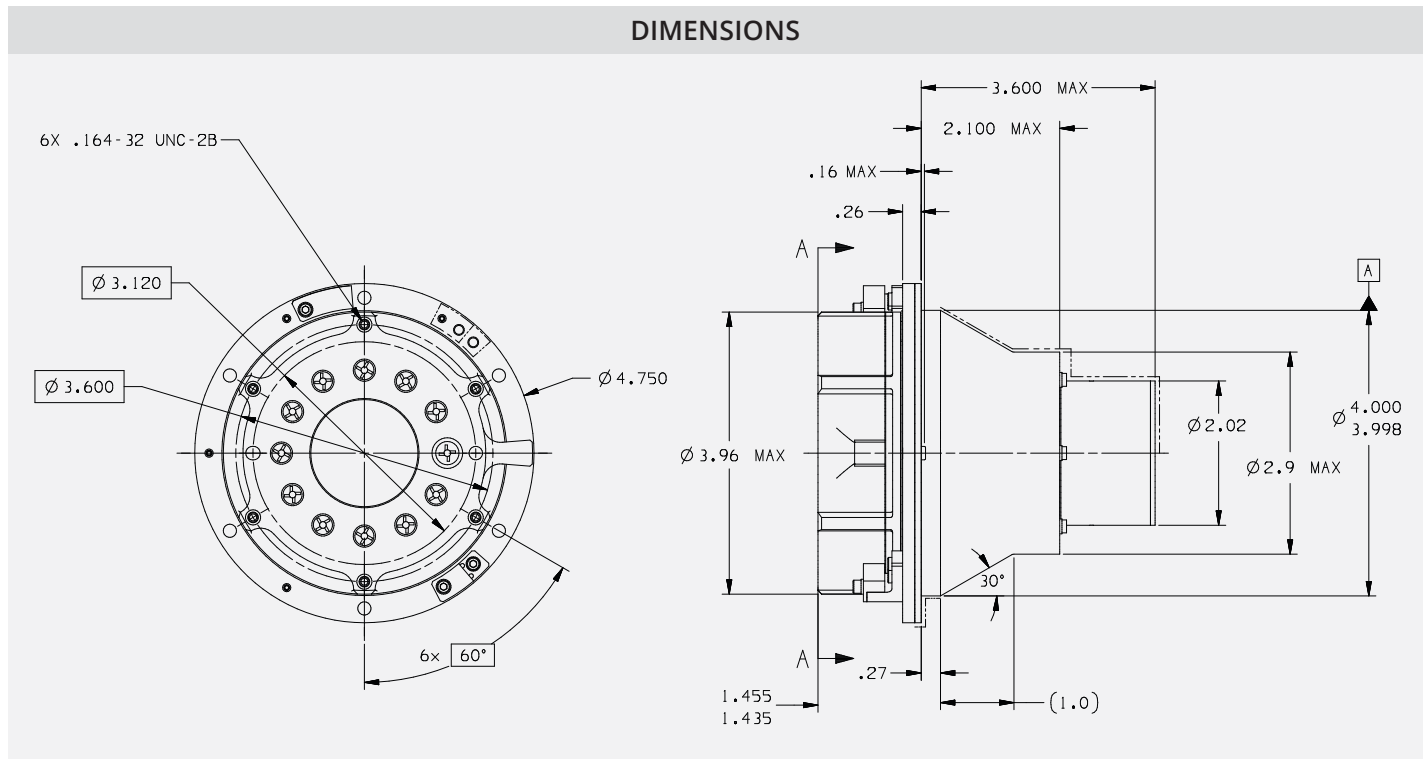

MOOG

Contact:
mechanisms@moog.com
www.moog.com/space



Moog Space and Defense



Moog Inc.



@Moog_Inc



@Moog.Inc

Equipment described herein falls under the jurisdiction of the EAR and may require US Government Authorization for export purposes. Diversion contrary to US law is prohibited.

© 2024 Moog, Inc. All rights reserved.
Product and company names listed are trademarks or trade names of their respective companies.

Form 500-613 120624