

TYPE 1 SOLAR ARRAY DRIVE ASSEMBLY (SADA)

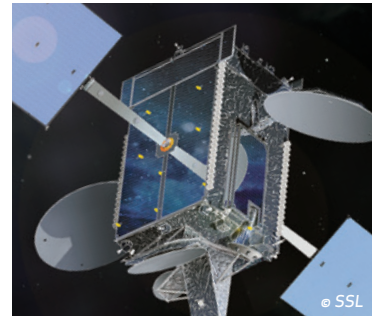

The Type 1 solar array drive assembly offers a minimum weight, minimum power solution for positioning solar array panels at the lower end of the size/power spectrum. It is based on the Moog Type 1 rotary incremental actuator. Continuous rotation of the solar array is facilitated by the integration of a slip ring assembly on the output of the actuator, and the rear accessory section of the Type 1

actuator is available for a position feedback device-potentiometer or encoder. Selecting the qualified unit in its existing configuration will have cost and schedule benefits; however, as with all Moog designs, the slip ring assembly is modular-substitutions and modifications to meet mission requirements are easily implemented. Integration of the actuator with another similar Type 1 actuator will produce a Type 11 biaxial SADA. Typical Type 1 performance specifications are shown in the table below. The unit is driven by the standard Moog Electronic Control Unit.



TYPE 1 SOLAR ARRAY DRIVE ASSEMBLY (SADA)

SPECIFICATIONS

Parameter	Data
Output Step Size	0.0375 Degrees
Output Torque	8.4 Nm
Unpowered Holding Torque	4.9 Nm
Power	8.6 W
Operating Temperature Range	-30° C to +65° C
Mass	1.16 Kg
Slip Ring Complement	30 @ 2 amp derated capacity / 45 volts
Position Sensor	Potentiometer ±0.36 degree

SADA DIMENSIONS

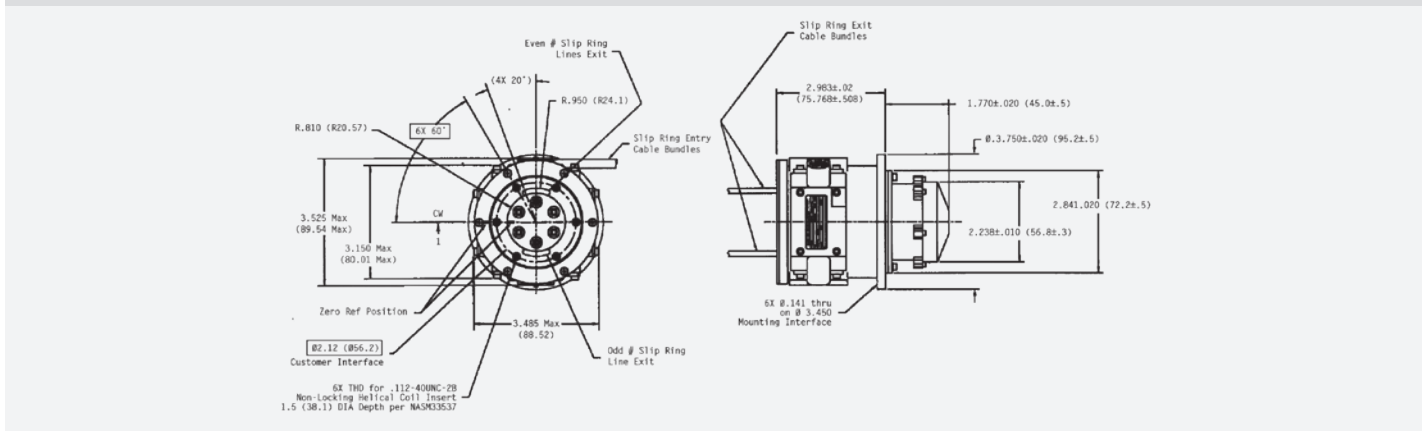

HERITAGE PROGRAMS

MIGHTY SAT, WILD GEESE, P925, STP/SIV

Solar array drives are a long-established product at Moog. The trend toward spacecraft of smaller sizes has led to smaller solar arrays and a need for miniaturized solar array drives. The Type 1 SADA is a reflection of that trend - it is the smallest solar array drive produced to date at Moog. Since the Type 1 actuator does not have the central wire conduit of larger actuators, the slip ring assembly is placed on the actuator output. The slip ring rotor is mounted to the actuator output, with the load interface flange transferred to the end of the slip ring rotor. The non load-bearing brush block housing surrounds the slip ring rotor and accommodates the solar array wiring. Exit wire bundles to the rotating solar array are taken out at the edges of the SADA output flange. Heritage units are both single axis and biaxial gimbals. The Type 11 biaxial unit is an orthogonal combination of two Type 1 actuators, with the common biaxial configuration of continuous rotation on the inner axis and limited rotation on the outer axis. A flexing loop of cable accommodates the motion on the outer axis, and rotational stops on that actuator protect the cable loop in operation.

Type 1 actuators are available with both potentiometers and incremental optical encoders for position feedback.



21339 Nordhoff Street, Chatsworth, CA 91311
 Sandra Browne - sbrowne@moog.com (International)
 Scott Reynolds - sreynolds@moog.com (USA & Canada)
 +1.818.734.6700 • www.moog.com



Moog Space and Defense



@MoogSDG



@MoogSDG



@MoogSDG

Equipment described herein falls under the jurisdiction of the EAR and may require US Government Authorization for export purposes. Diversion contrary to US law is prohibited.

© 2019 Moog, Inc. All rights reserved.
 Product and company names listed are trademarks or trade names of their respective companies.